



INSTINCT OWNER'S MANUAL



630839

ISSUED SEPTEMBER 2012

WELCOME

Thank you for purchasing this vehicle. Before driving the vehicle, we ask you to spend some time reading this Owner's Guide. This guide contains the information that will assist you in maintaining this highly reliable vehicle. Some illustrations may show items that are optional for your vehicle. This guide covers the operation of several vehicles; therefore, some illustrations may not represent your vehicle. Physical differences in controls will be illustrated.

Most of the service procedures in this guide can be accomplished using common, automotive hand tools. Contact your service representative on servicing the vehicle in accordance with the Periodic Service Schedule.

Repair or replacement parts are available through your BAD BOY BUGGIES retailer.

The following information is needed when contacting us concerning service or parts for your vehicle:

Vehicle Model _____

VIN or Serial Number _____

Manufacture Date Code _____

OWNER'S GUIDE

ELECTRIC POWERED

INSTINCT

Starting Model Year 2013

Never modify the vehicle in any way that will alter the weight distribution of the vehicle, decrease its stability or increase the speed beyond the factory specifications. Such modifications can cause serious personal injury or death. Bad Boy Buggies prohibits and disclaims responsibility for any such modifications or any other alteration which would adversely affect the safety of the vehicle.

BB Buggies Inc. reserves the right to incorporate engineering and design changes to products in this manual, without obligation to include these changes on units sold previously.

The information contained in this manual may be revised periodically by BB Buggies Inc., and therefore is subject to change without notice.

BB Buggies Inc. DISCLAIMS LIABILITY FOR ERRORS IN THIS MANUAL, and SPECIFICALLY DISCLAIMS LIABILITY FOR INCIDENTAL AND CONSEQUENTIAL DAMAGES resulting from the use of the information and materials in this Manual.

TO CONTACT US

Bad Boy Buggies
1451 Marvin Griffin Rd.
Augusta, GA. 30906

FAX: 888-256-9900

E-mail: info@badboybuggies.com

**For parts and repair contact your local dealer. To locate a local dealer please go online to our web site:
www.BADBOYBUGGIES.com**



GENERAL INFORMATION

Read all of this manual to become thoroughly familiar with this vehicle. Pay particular attention to all Notices, Cautions, Warnings, and Dangers.

This vehicle has been designed and manufactured in the United States of America (USA) as a 'World Vehicle'. The Standards and Specifications listed in the following text originate in the USA unless otherwise indicated.

The use of non Original Equipment Manufacturer (OEM) approved parts may void the warranty.

Overfilling battery may void the warranty.

Tampering with or adjusting the governor to permit vehicle to operate at above factory specifications will void the vehicle warranty.

When servicing engines, all adjustments and replacement components must be per original vehicle specifications in order to maintain the United States of America Federal and State emission certification applicable at the time of manufacture.

BATTERY PROLONGED STORAGE

All batteries will self discharge over time. The rate of self discharge varies depending on the ambient temperature and the age and condition of the batteries.

A fully charged battery will not freeze in winter temperatures unless the temperature falls below -75° F (-60° C).

The controller should be disconnected from the batteries by setting the RUN-MAINTENANCE/STORAGE switch, located under the seat on the passenger side, to the MAINTENANCE/STORAGE position. The batteries must be cleaned and all deposits neutralized and removed from the battery case to prevent self discharge.

The battery charger may be left connected to the vehicle to maintain a full charge on the batteries, provided the charger is plugged into an active electrical source. If power to the electrical source is disconnected or interrupted the battery charger will continue to check the charge on the battery pack, this will draw power from the battery pack and eventually drain the batteries if power is not restored in a timely manner.

BATTERY DISPOSAL

Lead-acid batteries are recyclable. Return whole scrap batteries to distributor, manufacturer or lead smelter for recycling. For neutralized spills, place residue in acid-resistant containers with absorbent material, sand or earth and dispose of in accordance with local, state and federal regulations for acid and lead compounds. Contact local and/or state environmental officials regarding disposal information.

WARRANTY

Separate inserts supplied in packaging with the vehicle provide information on Product Warranty and on Emissions Warranty. Failure to follow instructions for emission parts replacement may violate Federal Law (40 CFR part 1068.105 (b)) and be subject to fines and other penalties as described in the Clean Air Act.



TABLE OF CONTENTS

Read all of this manual to become thoroughly familiar with this vehicle. Pay particular attention to all Notices, Cautions, Warnings, and Dangers.

SECTION	PAGE NO.
SAFETY	1-1
GENERAL SPECIFICATIONS	2-1
INTRODUCTION	3-1
OPERATING PROCEDURES	4-1
MAINTENANCE	5-1

Read all of this manual to become thoroughly familiar with this vehicle. Pay particular attention to all Notices, Cautions, Warnings, and Dangers.

TITLE	PAGE NO.
GENERAL	1-2
NOTICES, CAUTIONS, WARNINGS, AND DANGERS.....	1-2
GENERAL OPERATION	1-3
MAINTENANCE	1-3
VENTILATION	1-4
LABELS AND PICTOGRAMS.....	1-5

SAFETY

1

Read all of this manual to become thoroughly familiar with this vehicle. Pay particular attention to all Notices, Cautions, Warnings, and Dangers.
This manual has been designed to assist in maintaining the vehicle in accordance with procedures developed by the manufacturer. Adherence to these procedures and troubleshooting tips will ensure the best possible service from the product. To reduce the chance of personal injury or property damage, the following must be carefully observed:



CAUTION

Certain replacement parts can be used independently and/or in combination with other accessories to modify an E-Z-GO-manufactured vehicle to permit the vehicle to operate at or in excess of 20mph. When an E-Z-GO-manufactured vehicle is modified in any way by the Distributor, Dealer or customer to operate at or in excess of 20mph, UNDER FEDERAL LAW the modified product will be a Low Speed Vehicle (LSV) subject to the strictures and requirements of Federal Motor Vehicle Safety Standard 571.500. In these instances, pursuant to Federal law the Distributor or Dealer MUST equip the product with headlights, rear lights, turn signals, seat belts, top, horn and all other modifications for LSV's mandated in FMVSS 571.500, and affix a Vehicle Identification Number to the product in accordance with the requirements of FMVSS 571.565. Pursuant to FMVSS 571.500, and in accordance with the State laws applicable in the places of sale and use of the product, the Distributor, Dealer or customer modifying the vehicle also will be the Final Vehicle Manufacturer for the LSV, and required to title or register the vehicle as mandated by State law.

E-Z-GO will NOT approve Distributor, Dealer or customer modifications converting E-Z-GO products into LSV's.

The Company, in addition, recommends that all E-Z-GO products sold as personal transportation vehicles BE OPERATED ONLY BY PERSONS WITH VALID DRIVERS LICENSES, AND IN ACCORDANCE WITH APPLICABLE STATE REQUIREMENTS. This restriction is important to the SAFE USE AND OPERATION of the product. On behalf of E-Z-GO, I am directing that E-Z-GO Branch personnel, Distributors and Dealers advise all customers to adhere to this SAFETY RESTRICTION, in connection with the use of all products, new and used, the Distributor or Dealer has reason to believe may be operated in personal transportation applications.

Information on FMVSS 571.500 can be obtained at Title 49 of the Code of Federal Regulations, section 571.500, or through the Internet at the website for the U.S. Department of Transportation - at Dockets and Regulation, then to Title 49 of the Code of Federal Regulations (Transportation).

GENERAL

All vehicles can be used for a variety of tasks beyond the original intended use of the vehicle; therefore, it is impossible to anticipate and warn against every possible combination of circumstances that may occur. No warning can take the place of good common sense and prudent driving practices.

Good common sense and prudent driving practices do more to prevent accidents and injury than all of the warnings and instructions combined. E-Z-GO strongly suggests that all users and maintenance personnel read this entire manual paying particular attention to the CAUTIONS, WARNINGS and DANGERS contained therein.

If you have any questions regarding this vehicle, contact your E-Z-GO Dealer or write to the address on the back cover of this publication, Attention: Customer Care Department.

E-Z-GO reserves the right to make design changes without obligation to make these changes on units previously sold and the information contained in this manual is subject to change without notice.

E-Z-GO IS NOT LIABLE FOR ERRORS IN THIS MANUAL. E-Z-GO IS NOT LIABLE FOR INCIDENTAL OR CONSEQUENTIAL DAMAGES THAT RESULT FROM THE USE OF THE MATERIAL IN THIS MANUAL.

This vehicle conforms to the current applicable standard(s) for safety and performance requirements.

These vehicles are designed and manufactured for off-road use. They DO NOT conform to Federal Motor Vehicle Safety Standards of the United States of America (USA) and are not equipped for operation on public streets. Some communities may permit these vehicles to be operated on their streets on a limited basis and in accordance with local ordinances.

With electric powered vehicles, be sure that all electrical accessories are grounded directly to the battery (-) post.

Never use the chassis or body as a ground connection.

Refer to GENERAL SPECIFICATIONS for vehicle seating capacity.

Read all of this manual to become thoroughly familiar with this vehicle. Pay particular attention to all Notices, Cautions, Warnings, and Dangers.

Never modify the vehicle in any way that will alter the weight distribution of the vehicle, decrease its stability or increase the speed or extend the stopping distance beyond the factory specification. Such modifications can result in serious personal injury or death.

Do not make modifications or changes, E-Z-GO prohibits and disclaims responsibility for any such modifications or any alterations which would adversely affect the safety of the vehicle.

Operation of the vehicle is limited to persons above the height of 59 inches (150 cm).

GENERAL OPERATION

ALWAYS:

- Use the vehicle in a responsible manner and maintain the vehicle in safe operating condition.
- Read and observe all warnings and operation instruction labels affixed to the vehicle.
- Follow all safety rules established in the area where the vehicle is being operated.
- Leave the vehicle when there is a risk of lightning.
- Reduce speed to compensate for poor terrain or conditions.
- Apply service brake to control speed on steep slopes.
- Maintain adequate distance between vehicles.
- Reduce speed in wet areas and when driving through water.
- Use extreme caution when approaching sharp or blind turns.
- Use extreme caution when driving over loose terrain or through running water.
- Use extreme caution in areas where pedestrians are present.

MAINTENANCE

ALWAYS:

- Maintain the vehicle in accordance with the manufacturer's periodic service schedule.
- Ensure that repairs are performed by those that are trained and qualified to do so.
- Follow the manufacturer's maintenance procedures for the vehicle. Be sure to disable the vehicle before performing any maintenance. Disabling includes removing the key from the key switch and removal of a battery wire.
- Insulate any tools used within the battery area in order to prevent sparks or battery explosion caused by shorting the battery terminals or associated wiring. Remove the battery or cover exposed terminals with an insulating material.
- Check the polarity of each battery terminal and be sure to rewire the batteries correctly.
- Use specified replacement parts. Never use replacement parts of lesser quality.
- Use recommended tools.
- Determine that tools and procedures not specifically recommended by the manufacturer will not compromise the safety of personnel nor jeopardize the safe operation of the vehicle.
- Support the vehicle using wheel chocks and jack stands. Never get under a vehicle that is supported by a jack. Lift the vehicle in accordance with the manufacturer's instructions.
- Maintain the vehicle in an area away from exposed flame or persons who are smoking.
- Be aware that a vehicle that is not performing as designed is a potential hazard and must not be operated.
- Test drive the vehicle after any repairs or maintenance. All tests must be conducted in a safe area that is free of both vehicular and pedestrian traffic.
- Replace damaged or missing warning, caution or information labels.
- Keep complete records of the maintenance history of the vehicle.

SAFETY

Read all of this manual to become thoroughly familiar with this vehicle. Pay particular attention to all Notices, Cautions, Warnings, and Dangers.

1 The manufacturer cannot anticipate all situations, therefore people attempting to maintain or repair the vehicle must have the skill and experience to recognize and protect themselves from potential situations that could result in severe personal injury or death and damage to the vehicle. Use extreme caution and, if unsure as to the potential for injury, refer the repair or maintenance to a qualified mechanic.

VENTILATION

Hydrogen gas is generated in the charging cycle of batteries and is explosive in concentrations as low as 4%. Because hydrogen gas is lighter than air, it will collect in the ceiling of buildings necessitating proper ventilation. Five air exchanges per hour is considered the minimum requirement.

NEVER charge a vehicle in an area that is subject to flame or spark. Pay particular attention to natural gas or propane gas water heaters and furnaces.

Chargers must be installed and operated in accordance with charger manufacturers recommendations or applicable electrical code (whichever is higher).

ALWAYS:

- Use a dedicated circuit for each battery charger. Do not permit other appliances to be plugged into the receptacle when the charger is in operation.
- Charge vehicle in an area free of flames or sparks.
- Operate battery charger in accordance with manufacturers recommendations.

SPECIFICATIONS

Read all of this manual to become thoroughly familiar with this vehicle. Pay particular attention to all Notices, Cautions, Warnings, and Dangers.

TITLE	PAGE NO.
INSTINCT VEHICLE SPECIFICATIONS	2-2
INSTINCT VEHICLE DIMENSIONS.....	2-3
TURNING DIAMETER AND INCLINE INFORMATION	2-4

SPECIFICATIONS

Read all of this manual to become thoroughly familiar with this vehicle. Pay particular attention to all Notices, Cautions, Warnings, and Dangers.

VEHICLE SPECIFICATIONS



A Textron Company

MODEL: INSTINCT
TYPE: ELECTRIC OFF ROAD VEHICLE
MODEL YEAR: 2013
Part No: 629234



PRODUCT SPECIFICATION

CONFIGURATION HIGHLIGHTS

Programmable AC Drive System: Factory programmable to application

- Solid State variable frequency AC speed controller
- Drive-by-wire electronic throttle control
- Console mounted direction selector switch (Forward-Neutral-Reverse)
- Descent speed control
- Full-time regenerative braking
- 300 Amp AC Controller
- Full torque, reduced speed reverse
- Sealed Hall effect throttle sensor
- Full diagnostic capability (Hand held diagnostic unit)
- Dash mounted Max Speed/Max Range speed selector switch

Motor: One 72 Volt AC induction motor, solid copper windings. 19 hp (12.4 kW) peak. AC system reads motor speed for accurate speed control in all conditions. Regenerative braking for maximum economy

Battery Charger: Remote 72 VDC DPI Charger, 120 VAC 60 Hz or optional 230VAC 50Hz unit. (U.L. Certified)

Electrical System: 72 Volt DC, six 12 volt deep cycle storage batteries

Drive Train: Direct motor shaft connected to transaxle pinion shaft

Transaxle: Differential with reverse helical gears

Brakes: 4-wheel hydraulic disc brakes and Induction motor. Manual parking brake

Body Protection: Front Brush Guard

PRODUCT OVERVIEW

Dimensions

Overall Length	111.0 in	282 cm
Overall Width	52.0 in	132 cm
Overall Height	76.5 in	194 cm
Wheel Base	69.0 in	175 cm
Gnd Clearance @ Frame	16.5 in	42 cm
Gnd Clearance @ Differential	10.0 in	25 cm

Vehicle Power

Power Source	72 Volts DC
Motor Type	72 Volts AC
Horsepower (kW)	19 hp 12.4 kW
Electrical System	72 Volt
Batteries (Qty, Type)	Six 12V Deep Cycle
Key or Pedal Start	Key Start
Speed Controller	300 amp
Drive Train	Motor Shaft Direct Drive
Transaxle	Hardened Helical Gears
Direction Selection	Console mounted Forward-Neutral-Reverse
Speed Selection	Dash mounted Speed/Range switch
Rear Axle Ratio	(F&R)
Front Axle Ratio	12.49:1

Performance

Seating Capacity & Style	2 Persons - Bench Seat	
Curb Weight	1,528 lb	693 kg
Vehicle load capacity	840 lb	381 kg
Gross Axle Weight Rating - F	567 lb	257 kg
Gross Axle Weight Rating - R	1,801 lb	817 kg
Outside Clearance Circle	24 ft	7.5 m
Speed - Low (Level Ground)	16.0 mph	25.7 kph
Speed - High (Level Ground)	24.5 mph	39.4 kph
Speed - Reverse	10.0 mph	16.1 kph

Steering & Suspension

Steering	Double Ended Rack & Pinion - 3.69 turns to lock
Front Suspension	MacPherson Strut
Rear Suspension	MacPherson Strut
Service Brake	4-Wheel Hydraulic Disc with Motor Regen
Parking Brake	Manual w/controller cut-out
Tires / Wheels	25X10-12 Mud-Lite / 12" Black Steel

Body & Chassis

Frame	Welded Steel with DuraShield powder coat
Body & Finish	Injection Molded TPO & Automotive Style Paint
Standard Color	Matte Black
Cargo Bed	9.7 Cu. Ft. Polyethylene Bed

Some items shown may be optional equipment

Specifications are subject to change without notice
 * Field installed accessories may require installation charges

SPECIFICATIONS

Read all of this manual to become thoroughly familiar with this vehicle. Pay particular attention to all Notices, Cautions, Warnings, and Dangers.

VEHICLE DIMENSIONS

2

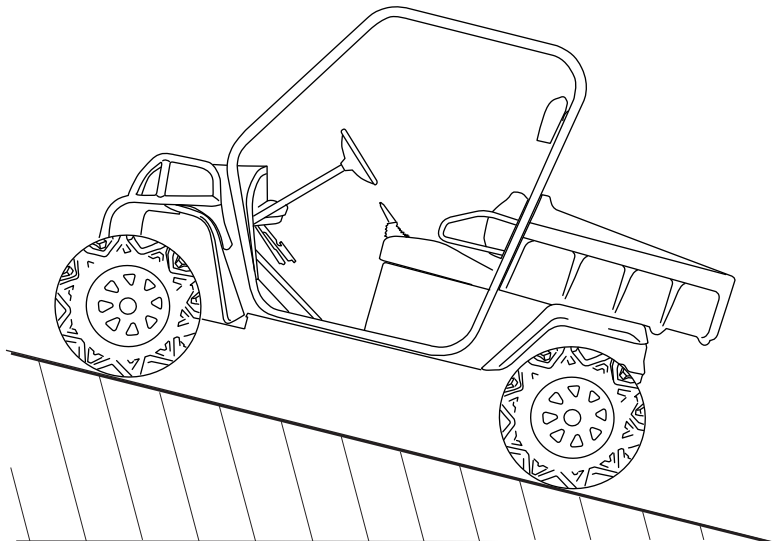
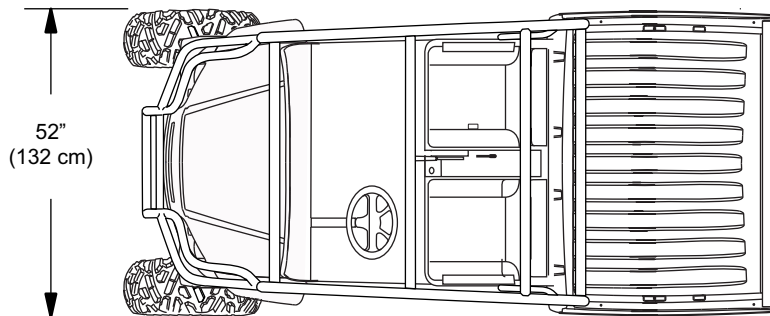
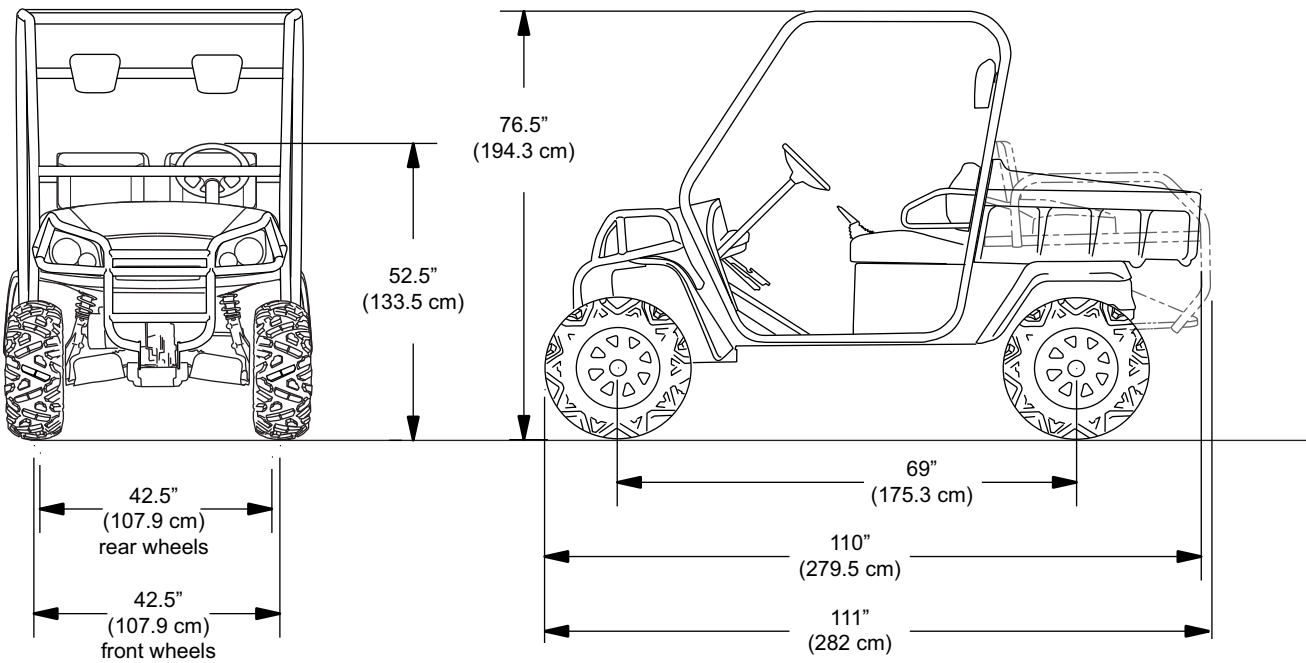

Maximum Recommended Ramp Grade
25% or 14° Max.

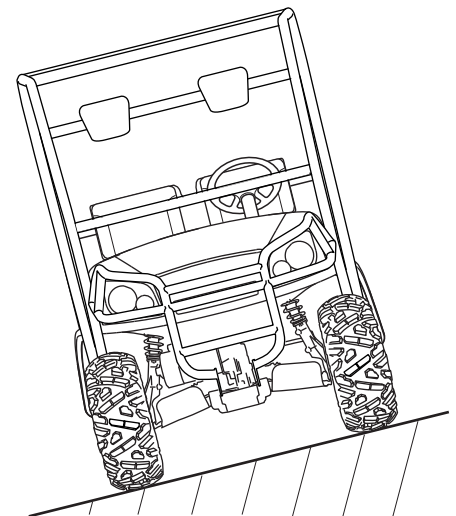

Maximum Recommended Side Tilt
25% or 14° Max.

SPECIFICATIONS

Read all of this manual to become thoroughly familiar with this vehicle. Pay particular attention to all Notices, Cautions, Warnings, and Dangers.

Notes:

2



INTRODUCTION

Read all of this manual to become thoroughly familiar with this vehicle. Pay particular attention to all Notices, Cautions, Warnings, and Dangers.

TITLE	PAGE NO.
OPERATOR CONTROLS	3-2
Key Switch / Direction Selector	3-2
Accelerator Pedal	3-2
Brake Pedal	3-2
Park Brake	3-2
Differential Lock	3-2
FEATURES	3-3
State of Charge Meter	3-3
Headlight	3-3
Winch Switch	3-3
12 Volt Power Outlet	3-3
Charger Receptacle	3-4
Electric Lift Switch	3-4
Winch Remote Receptacle	3-4
Truck Bed Latch	3-4
Truck Bed	3-4
Tail Lights	3-4
Rear Seat / Load Deck	3-5
Side Net	3-5



INTRODUCTION

Read all of this manual to become thoroughly familiar with this vehicle. Pay particular attention to all Notices, Cautions, Warnings, and Dangers.

OPERATOR CONTROLS

1. Key Switch

Located on the on the seat panel between the driver and passenger seats, this key operated switch enables the basic electrical system of the vehicle to be turned on and off. Rotate the switch clockwise to power the electrical system ON and counterclockwise to turn the power OFF.

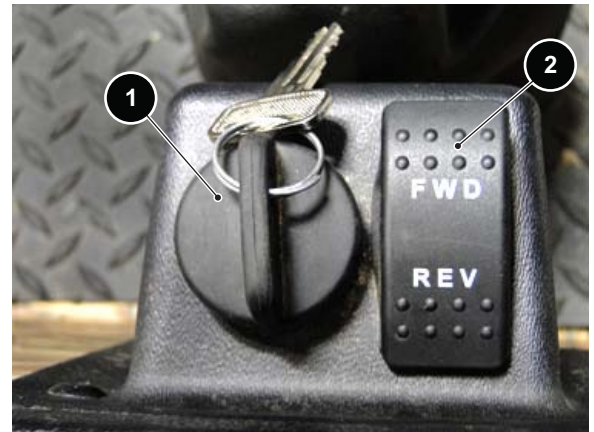

2. Direction Selector

Located on the on the seat panel between the driver and passenger seats, this three position switch is used to select either FWD (forward), REV (reverse) or neutral for vehicle direction. Before turning the key to the ON position the direction selector must be set to neutral. The switch should always be left in N (neutral) when vehicle is unattended.

3. Accelerator Pedal

With the key switch 'ON', depressing the accelerator pedal starts the electric motor. When the pedal is released, the motor will stop and the vehicle will slow down. To stop the vehicle more quickly, depress the brake pedal.

4. Brake Pedal

Depress the brake pedal to slow and stop the vehicle. This vehicle is equipped with four wheel hydraulic brakes; disc brakes on all four wheels.

5. Park Brake

The hand operated park brake is located on the floor to the right of the driver. The brake is engaged when the handle is pointed upward and disengaged when the handle is almost parallel to the floor. When leaving the vehicle unattended, engage the park brake by raising the handle until it is locked in place. To release the park brake push the handle down towards the floor.

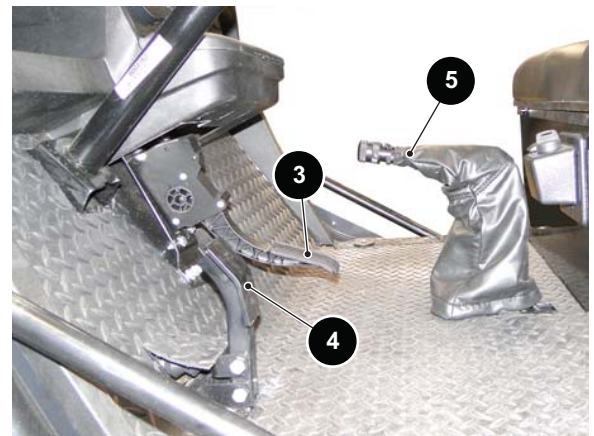

Read all of this manual to become thoroughly familiar with this vehicle. Pay particular attention to all Notices, Cautions, Warnings, and Dangers.

FEATURES

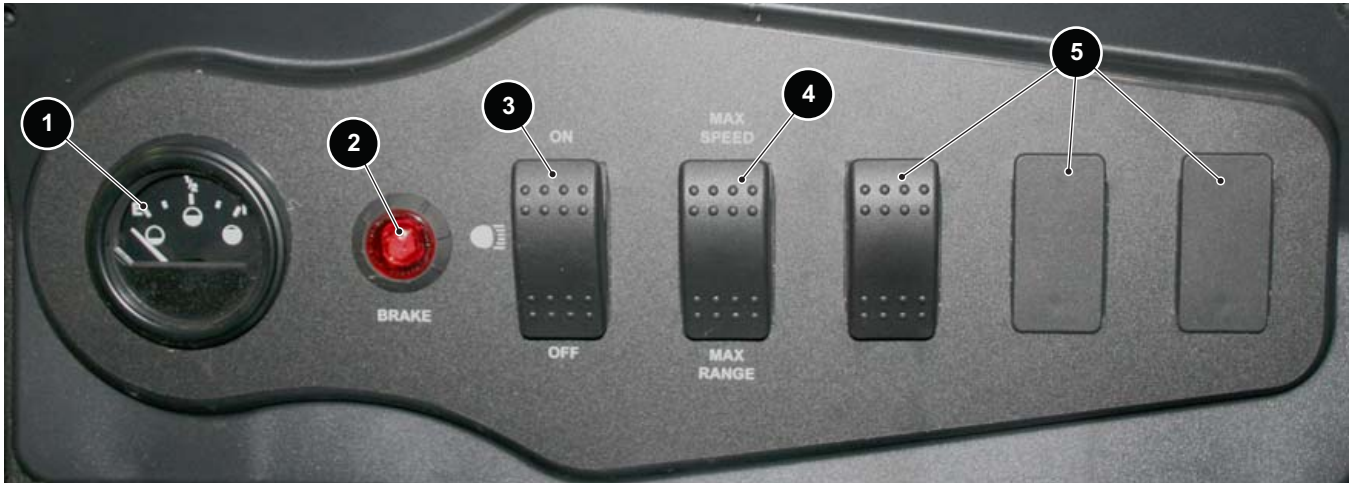

3

1. State of Charge Meter/Fuel Gauge

Electric fuel gauge located on the left side of the dash panel, indicates the amount of charge remaining in the battery pack when the key switch is in the ON position.

2. Brake Light

The indicator light illuminates to indicate that the parking brake is engaged.

3. Headlight Switch

Located on the dash panel to the right of the brake light. The switch has two positions, ON and OFF. In the ON position the headlights and all dash panel lights will be on, the OFF position will turn off the lights.

4. Max Range/Max Speed

Two position switch located in the dash panel. The Max Range setting limits the top speed of the vehicle to 16 MPH, saving battery power to extend the range of the vehicle when operated at full speed. The Max Speed setting allows the vehicle to travel up to 24 MPH and sacrifices distance for speed.

5. Auxiliary Switch Positions

There is space for the addition of three rectangular toggle switches to control additional lights or accessories.

6. Winch Switch (if equipped)

Located in the driver side glove box.



INTRODUCTION

Read all of this manual to become thoroughly familiar with this vehicle. Pay particular attention to all Notices, Cautions, Warnings, and Dangers.

7. 12 Volt Power Outlet

Located in the passenger side glove box. The 12 volt outlet will supply a constant power supply for accessories equipped with a 12 volt plug.



8. Charger Receptacle

The polarized charger receptacle for the electric battery pack is located in the seat wrap panel below the seat on the driver side. Always check to be sure the receptacle is free from dirt and debris before connecting the charger cord.



9. Truck Bed Latch

Located at the front of the manual lift truck bed. To release the latching mechanism pull the handle upward then raise the front of the truck bed up.

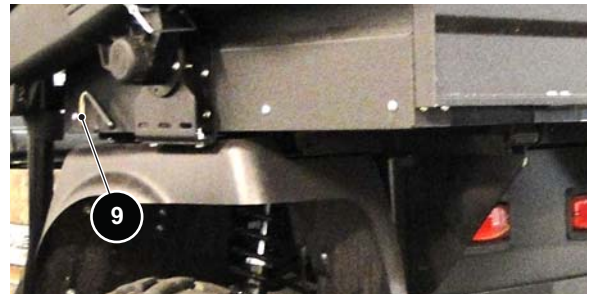

10. Truck Bed

Two truck beds are available, a molded plastic bed or an aluminum bed.

11. Tail Lights

The tail lights are located in the rear below the truck bed. The tail lights will illuminate



INTRODUCTION

Read all of this manual to become thoroughly familiar with this vehicle. Pay particular attention to all Notices, Cautions, Warnings, and Dangers.

12. Head Protection

Rubber pads to protect the head when driving over rough terrain.

13. Side Nets

Side nets are a standard safety feature provided with the vehicle and must be properly secured before operating vehicle.

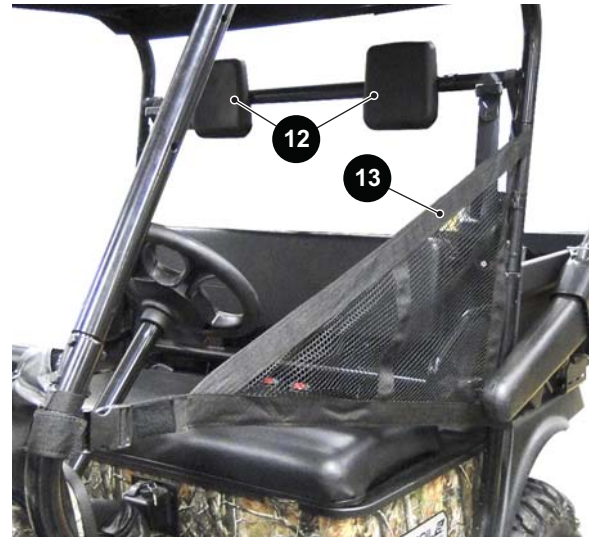

3

14. Rear Seat / Load Deck (if equipped)

The rear facing seat is designed for two occupants, on each side of the seat. The load deck is created by unfolding the bottom of the rear facing seat.



OPERATION

Read all of this manual to become thoroughly familiar with this vehicle. Pay particular attention to all Notices, Cautions, Warnings, and Dangers.

TITLE	PAGE NO.
VIN AND SERIAL NUMBER LOCATION	4-2
BEFORE INITIAL USE	4-2
PORTABLE CHARGER.....	4-3
Using the Charger	4-4
OPERATING THE VEHICLE	4-5
COMMON SENSE OPERATION	4-5
ENVIRONMENTAL CONCERNS.....	4-6
STARTING AND DRIVING	4-6
Starting On A Hill	4-7
COASTING.....	4-7
TOP AND WINDSHIELD	4-7
TOWING A TRAILER	4-7
TERRAIN.....	4-8
DUMP BED.....	4-8
REAR FACING SEAT/LOAD DECK.....	4-8
WINCH.....	4-9
Winch Application	4-9



OPERATION

Read all of this manual to become thoroughly familiar with this vehicle. Pay particular attention to all Notices, Cautions, Warnings, and Dangers.

VIN AND SERIAL NUMBER LOCATION

The VIN plate is riveted to the top of the cowl on the driver side.

Two serial number and manufacture date code plates are on the vehicle. One is placed on the steering column, the other is located on the chassis under the driver seat bottom.

Design changes take place on an ongoing basis. In order to obtain correct components for the vehicle, the VIN number, manufacture date code, serial number, vehicle model manufacture date code, must be provided when ordering service parts.

WARNING

Improper use of this vehicle could result in severe injury or death. The buggy is a light duty utility vehicle, NOT an All Terrain Vehicle (ATV).

To reduce the possibility of severe injury or death resulting from loss of vehicle control the following warnings must be observed:

When driving vehicle, consider the terrain, traffic conditions and the environmental factors which affect the terrain and the ability to control the vehicle.

Use extra care and reduced speed when driving on poor surfaces, such as loose dirt, wet grass or gravel.

Maintain a safe speed when driving up or down a hill. Use service brake to control speed when traveling down an incline. A sudden stop or change of direction may result in loss of control.

To prevent loss of control, do not move the vehicle direction selector while the vehicle is in motion. moving the direction selector will result in a sudden slowing of the vehicle.

Slow down before and during turns. All turns should be made at reduced speed.

Do not drive through water that is over 12 inches deep.

To prevent inadvertent movement when the vehicle is to be left unattended, engage the parking brake, turn key to OFF position and remove key.

Make sure the direction selector is set to the Neutral position before attempting to start the vehicle.

Always bring the vehicle to a complete stop before shifting the direction selector.

Do not take vehicle out of gear while in motion (coast).

Check area behind vehicle before operating in reverse.

All occupants must be seated with seat belts fastened and front side nets latched. Keep entire body inside vehicle and hold on while vehicle is in motion.

BEFORE INITIAL USE

Be sure you understand the vehicle, its equipment and how to use it safely. Read, understand and follow the safety and operation label on the lower OPS cross bar. Although the vehicle has been designed to provide safe and reliable operation, maintaining good performance depends, to a large extent, on the operator.

Read all of this manual to become thoroughly familiar with this vehicle. Pay particular attention to all Notices, Cautions, Warnings, and Dangers.

Before a new vehicle is put into operation, the items shown in the **INITIAL SERVICE CHART** must be performed.

Remove the battery charger and read the operation instructions for the charger before charging the battery set.

Vehicle batteries must be fully charged before initial use.

Check for correct tire inflation. See GENERAL SPECIFICATIONS.

Check the hydraulic brake fluid level.

Remove the protective clear plastic, that protect the seat bottom and back rest during shipping, before placing the vehicle in service.

ITEM	SERVICE OPERATION
Battery Charger	Remove from vehicle and read operating instructions.
Batteries	Charge batteries.
Seats	Remove protective plastic covering.
Brakes	Check operation, adjust if necessary. Check hydraulic brake fluid level.
Tires	Check air pressure, adjust if necessary. See vehicle specifications for tire pressure.

Initial Service Chart

WARNING

Hydrogen gas is generated as a natural part of the lead acid battery charging process. A 4% concentration of hydrogen gas is explosive and could cause severe injury or death. Charging must take place in an area that is adequately ventilated (minimum of 5 air exchanges per hour).

To reduce the chance of battery explosion that could result in severe injury or death, never smoke around or charge batteries in an area that has open flame or electrical equipment that could cause an electrical arc.

Hydrogen gas is generated in the charging cycle of batteries and is explosive in concentrations as low as 4%. Because hydrogen gas is lighter than air, it will collect in the ceiling of buildings necessitating proper ventilation.

Five air exchanges per hour is considered the minimum requirement.

Never charge a vehicle in an area that is subject to flame or spark. Pay particular attention to natural gas or propane water heaters and furnaces.

PORTABLE CHARGER

WARNING

Use charger ONLY on 72 volt battery systems. Other usage may cause personal injury and damage. Lead acid batteries may generate explosive hydrogen gas during normal operation. Keep sparks, flames, and smoking materials away from batteries. Provide adequate ventilation during charging. Never charge a frozen battery. Study all battery manufacturers' specific precautions such as recommended rates of charge and removing or not removing cell caps while charging.

DANGER

Risk of electric shock. Connect charger power cord to an outlet that has been properly installed and grounded in accordance with all local codes and ordinances. A grounded outlet is required to reduce risk of electric shock – do not use ground adapters or modify plug. Do not touch uninsulated portion of output connector or uninsulated battery terminal. Disconnect the DC supply before making or breaking the connections to the battery while charging. Do not open or disassemble charger. Do not operate charger if the AC supply cord is damaged or if the charger has received a sharp blow, been dropped, or otherwise damaged in any way – refer all repair work to qualified personnel. Not for use by children.

OPERATION

Read all of this manual to become thoroughly familiar with this vehicle. Pay particular attention to all Notices, Cautions, Warnings, and Dangers.

The portable charger is shipped with the vehicle. Prior to vehicle or charger operation, the charger **must** be removed from the vehicle. **A dedicated circuit is required for the charger.** Refer to the charger manual for appropriate circuit protection. For optimum performance and shortest charge times, place the charger in an area with adequate ventilation and relatively free of dirt, mud, or dust. If the charger is operated in an outdoor location, rain and sun protection must be provided. The charger may get hot during operation and must be placed such that risk of contact by people is reduced.

NOTICE

Looping the DC cord through the steering wheel when charging serves as a good reminder to store the cord out of the way when finished with charging. The DC plug can be damaged by driving over or catching the cord on the vehicle when driving away.

WARNING

An ungrounded electrical device may become a physical hazard that could result in an electrical shock or electrocution.

Using the Charger

Before using the charger read the operation manual that was supplied with the charger.

WARNING

To prevent a physical hazard that could result in an electrical shock or electrocution, be sure that the charger plug is not damaged and is inserted into a grounded receptacle.

The power (AC) cord is equipped with a grounded plug. Do not attempt to pull out, cut or bend the ground post.

The charging (DC) cord is equipped with a polarized connector that fits into a matching receptacle on the vehicle. The receptacle is located in the seat panel below the seat on the driver's side of the vehicle.



Read all of this manual to become thoroughly familiar with this vehicle. Pay particular attention to all Notices, Cautions, Warnings, and Dangers.

OPERATING THE VEHICLE

CAUTION

Improper use of the vehicle or the lack of proper maintenance may result in damage or decreased performance. Read and understand the following warnings before attempting to operate the vehicle.

WARNING

To reduce the possibility of severe injury or death resulting from loss of vehicle control, the following warnings must be observed:

When driving vehicle, consider the terrain, traffic conditions and the environmental factors which effect the terrain and the ability to control the vehicle.

Use extra care and reduced speed when driving on poor surfaces, such as loose dirt, wet grass, gravel, etc.

Maintain a safe speed when driving down hill. Use service brake to control speed when traveling down an incline. A sudden stop or change of direction may result in loss of control.

Slow down before and during turns. All turns should be made at reduced speed.

Never drive vehicle up, down, or across an incline that exceeds 14° (25% grade).

WARNING

To reduce the possibility of severe injury or death resulting from improper vehicle operation, the following warnings must be observed:

Refer to GENERAL SPECIFICATIONS for seating capacity.

Depressing accelerator pedal may cause inadvertent vehicle movement. Turn the key to the 'OFF' position whenever the vehicle is parked.

To prevent inadvertent movement when the vehicle is to be left unattended, engage the park brake, move direction selector to the neutral position, turn key to 'OFF' position and remove key.

Make sure that the direction selector is in neutral before attempting to start the vehicle.

Always bring the vehicle to a complete stop before shifting the direction selector.

Do not take vehicle out of 'gear' while in motion (coast).

Check the area behind the vehicle before operating in reverse.

All occupants must be seated and wearing their seat belts, front side nets must be latched. Keep entire body inside vehicle and hold on while vehicle is in motion.

COMMON SENSE OPERATION

WARNING

To prevent severe injury or death, observe the following:

Never transport loaded firearms on or in vehicle.

Check that firearms are unloaded with the safety engaged and are properly secured with muzzle pointing in a safe direction before operating vehicle. Be aware of other firearms in proximity to operator and passengers.

OPERATION

Read all of this manual to become thoroughly familiar with this vehicle. Pay particular attention to all Notices, Cautions, Warnings, and Dangers.

This vehicle is not a toy. If not operated properly and responsibly, it can cause severe injury or death to the operator, passengers or bystanders. All operators should possess a valid driver's license. Children should not be permitted to operate the vehicle. Children may not have the skill, judgement or strength to operate this or similar vehicles.

Alcohol, drugs and many over the counter medications reduce the ability of the driver to operate the vehicle safely. Always review side effects of any medication with a doctor or pharmacist before operating vehicle.

Protective clothing and an approved motorcycle helmet are recommended for operator and passengers when operating vehicle in rough or densely wooded terrain.

When driving at full speed on a dirt road, loose surfaces or wet grass, vehicle stopping distance will increase. If the vehicle is fully loaded, it will take longer to stop than with no load. When operating vehicle in wet weather conditions, remember that the brakes may need to be **lightly** applied in order to provide enough friction to dry the brake unit. If wet, the brakes will lose much of their effect.

Slow down when in unfamiliar terrain. Slow down when cresting a hill in an area that you are unfamiliar with.

Some hills are too steep to climb. If you attempt to climb a hill that is too steep or if you are unable to achieve adequate traction, **do not attempt to turn around on the hill. Slowly back straight down the hill using the service brake to control speed.**

ENVIRONMENTAL CONCERNS

WARNING

As a responsible user, practice respect for all wildlife and their habitat. Respect private property and comply with all local laws and regulations governing the use of light duty utility vehicles. To prevent severe injury or death while driving, be aware of the following:

Environmental hazards such as steep slopes, overhanging limbs, etc.

Danger of fire when vehicle is operated over dry combustible organic material.

When driving, be aware of environmental hazards such as steep slopes, overhanging limbs, etc. Be aware of the danger of fire when the gasoline powered vehicle is operated over dry combustible organic material.

STARTING AND DRIVING

- Make certain that the parking brake is engaged
- Make sure that the accelerator pedal is NOT depressed (no pressure on it)
- Make certain that the forward/reverse switch is in the neutral position
- Turn the key switch to the ON position and wait 3 - 5 seconds for the controllers to power up
- Release the parking brake fully
- Depress the accelerator pedal to move the buggy

Operation of this vehicle is limited to persons who are licensed drivers.

A two minute delay is programmed into the controllers; this causes the controllers to power down after two minutes of accelerator inactivity. To reset the accelerator, the forward/reverse switch must be cycled from forward or reverse to neutral and back to the desired direction before the buggy will move.

Always ensure that the forward/reverse switch is in the neutral position, the parking brake is set, the key switch is in the OFF position and the key is removed from the switch before exiting the buggy.

This vehicle is to be operated by licensed drivers only. Do not attempt to operate the buggy under the influence of drugs or alcohol. Never turn the key switch to OFF while the buggy is in motion, this can cause loss of control and lead to serious injury or death.

Use caution when traveling uphill or downhill; on a downhill slope it is possible for the buggy to achieve speeds greater than if it were operating on flat terrain. Speed on an uphill slope should be limited to not more than 5 mph and in a downhill situation must be limited to 5 mph by using the service brake to slow the vehicle. If allowed to travel too fast on a downhill slope loss of control may occur, this can cause serious injury or death.

Read all of this manual to become thoroughly familiar with this vehicle. Pay particular attention to all Notices, Cautions, Warnings, and Dangers.

Use caution when traveling through water and never operate vehicle in water over 12 inches deep.

Starting The Vehicle On A Hill

CAUTION

Do not hold vehicle on hill by using accelerator and motor. This will cause premature and excessive wear to drive train components.

To reduce the possibility of permanent damage to the drive system, it is important to prevent excessive roll-back when starting the vehicle on a hill.

Place left foot on service brake and release the park brake. Depress accelerator with right foot and release the service brake by lifting left foot.

COASTING

WARNING

To reduce the possibility of severe injury or death from coasting at above recommended speeds, limit speed with service brake.

On steep hills, it is possible for the vehicle to coast at greater than normal speeds encountered on a flat surface. To reduce the possible loss of vehicle control and severe drivetrain damage, speeds should be limited to no more than the maximum governed speed on level ground (see GENERAL SPECIFICATIONS). Limit speed by applying pressure to the brake pedal.

TOP AND WINDSHIELD (if equipped)

WARNING

The top does not provide protection from roll over or falling objects.

The windshield does not provide protection from tree limbs or flying objects.

Remove windshield and store securely for trailering this vehicle, the windshield is not designed to withstand highway speeds.

CAUTION

To prevent damage to the vehicle, do not hold on to sun top struts and stand on body panels.

The sun top and windshield provide some protection from the elements; however, they will not keep the operator and passenger dry in a downpour. This vehicle is equipped with seat belts and an OPS (operator protection system) the sun top has not been designed to provide roll over protection. In addition, the sun top does not protect against falling objects nor does the windshield protect against flying objects and tree limbs. Keep arms and legs inside of vehicle while it is moving.

TOWING A TRAILER

The vehicle is equipped with a receiver that can be fitted with a standard 1 7/8" ball. The trailer and its load must not exceed 500 lbs (227 kg) and no more than 50 lbs (23 kg) tongue weight may be attached to the hitch. Remember that the overall capacity of the vehicle, operator, passenger, contents of load bed and accessories must be reduced to compensate for the trailer and load.

The range of motion of the trailer is limited by the ball and hitch. The trailer should not be used on rough trails or over objects such as logs, large rocks, holes, etc.

OPERATION

Read all of this manual to become thoroughly familiar with this vehicle. Pay particular attention to all Notices, Cautions, Warnings, and Dangers.

Never install baskets or extensions using the hitch receivers. Such items will change the performance characteristics of vehicle and result in unsafe handling, possible roll over or vehicle damage.

TERRAIN

The vehicle is NOT designed for use on public roads. The vehicle may be used on established trails or open terrain that is free from stumps, large rocks or holes. The vehicle should not be used to cross water that is more than 12 inches (30 cm) deep or fast moving water.

Be aware of steep slopes, overhanging limbs or danger of fire when the gas engine is operated over dry combustible material. Consult dealer for an available spark arrestor for this vehicle.

When traveling up or down steep slopes do not attempt to turn the vehicle around on the slope. Vehicle stopping distance increases when driving on wet grass, dirt roads or loose surfaces.

DUMP BED

WARNING

Passengers should never be allowed to ride in the dump bed. Severe injury or death could result if they should fall out or the vehicle is involved in an accident or sudden maneuver.

Be careful when loading the vehicle. Secure loads to prevent shifting. Do not overload vehicle. A dump bed warning label is affixed to the inside of the bed on the front panel.

This label must be understood and observed at all times for safe operation of the vehicle. The dump bed is limited to a maximum load of 500 lbs. The load must be positioned in the bed as far forward as possible, it's center of gravity must not be higher than 12" above the bed floor, and securely fastened down. Failure to follow these instructions could cause personal injury, damage to the vehicle and/or cause the vehicle to tip over. Operate the vehicle with awareness of the load.

Do not drive the vehicle with the dump bed raised or with the tailgate unsupported.

When using the optional electric dump, be sure to avoid backing up to the edge of a drop off, such as a loading dock or ravine. A misjudgment of distance or an unstable surface could result in the vehicle falling backwards.

Always insure that no one is behind or close to the dump bed while the electric dump mechanism is being operated.

REAR FACING SEAT / LOAD DECK

WARNING

Passengers should never be allowed to ride on the load deck. Severe injury or death could result if they should fall out or the vehicle is involved in an accident or sudden maneuver.

The rear facing seat will accommodate two passengers with a combined weight of less than 400 pounds or, the seat bottom may be folded out to form a load deck. When using the load deck, position the load as far forward as possible and securely fastened down. The maximum load is 250 lbs and the center of gravity must not be higher than 12" above the load deck.

Read all of this manual to become thoroughly familiar with this vehicle. Pay particular attention to all Notices, Cautions, Warnings, and Dangers.

WINCH OPERATION (if equipped with winch)

This vehicle may be equipped with an optional winch. Read, understand and follow all of the information supplied with the winch on the operation and use of the winch before attempting to operate it.

Winch Application

A winch may be used for a number of purposes, including pulling the vehicle if it loses traction on unsuitable terrain.

WARNING

Improper use of the winch could result in a number of conditions that could cause severe injury or death to operator, occupants of vehicle or bystander.

It is impossible to predict all conditions that the winch could be used, therefore the following warnings should not be considered as complete. Before operating the winch, consider the possible dangers and take precautions to protect yourself, your passenger and any bystanders.

WARNING

To prevent severe injury or death to operator, occupants or bystanders, select the object to which the cable is attached with the following considerations:

Make sure the object cannot be pulled over or otherwise damaged.

The object the winch cable is attached to could fall on the vehicle and it's occupants.

If attaching the winch to a dead tree, a section could fall.

When pulling vehicle with winch, pull straight only. Do not permit the cable to contact the side of the drum.

Do not pull vehicle at an angle. If the vehicle is pulled at an angle, it could turn over causing severe injury or death to anyone in the area. The winch cable could also become overstressed and break causing severe injury or death to anyone struck by the cable.

The rear drive axle is equipped with a manually operated locking differential. With the differential unlocked, if one drive wheel loses traction, all available power is transferred to that wheel until it regains traction. In normal driving this is not a problem. However, if the vehicle becomes 'hung up' on an object, the vehicle will stop. With the differential locked, power is distributed to both drive wheels at all times. If both drive wheels lose traction as a result of the vehicle becoming 'hung up' on an object, the vehicle will stop. If the vehicle cannot be pushed off the obstruction, it will have to be pulled off using the winch.

WARNING

To prevent severe injury or death, read and understand the following before attempting to use the winch:

The winch is not intended to be used in any hoisting operation.

The rolling load capacity of the winch decreases with the steepness of the slope.

The winch is designed for intermittent duty only.

The electric motor should not be allowed to become excessively hot. If the motor becomes uncomfortably hot to the touch, stop winching and allow the motor to cool.

Always wear thick leather gloves when handling the wire cable.

Replace frayed wire cable with a direct factory replacement only.

OPERATION

Read all of this manual to become thoroughly familiar with this vehicle. Pay particular attention to all Notices, Cautions, Warnings, and Dangers.

Never operate the winch with less than five (5) full turns of cable around the drum.

If the winch motor stalls from overloading, do not continue to activate the winch remote control. The wire cable may become overstressed.

Do not attempt to pull loads exceeding the manufacturers maximum load rating.

Have all persons and pets leave the area while operating winch. Never allow anyone to remain in the vehicle.

To prevent damage to the wire cable, never hook the cable to itself. Always use a nylon sling.

Stay clear of the winch, the cable and the cable hook. Place a heavy cloth, jacket or blanket over the cable to act as a damper should the cable break when operating the winch.

When operating the winch, keep the entire area in view.

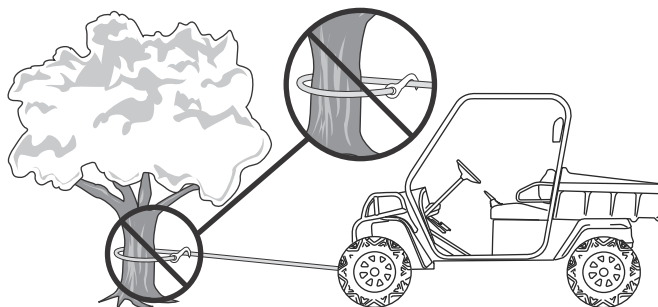

Do Not Hook Cable to Itself

Never release the free spool clutch while the cable is under load.

Never work around the winch drum or the winch cable while it is under tension.

Unplug the winch switch before working on the winch drum in order to prevent inadvertent operation.

When operating winch, take up slack slowly. Stop winch before cable becomes tight and inspect all winching connections. Check winch attachment, hook attachment, nylon sling (if required) and load attachment.

Do not pull at an angle. This will cause the wire cable to pile up on one end of the winch. This may jam the winch causing damage to the cable and/or the winch. Pulling the vehicle at an angle can cause damage to the front suspension and may cause the vehicle to overturn. When pulling vehicle, pull straight only.

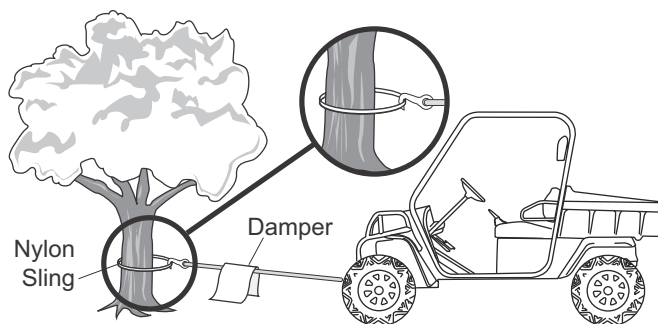

Use a Nylon Sling and Install a Damper when Winching

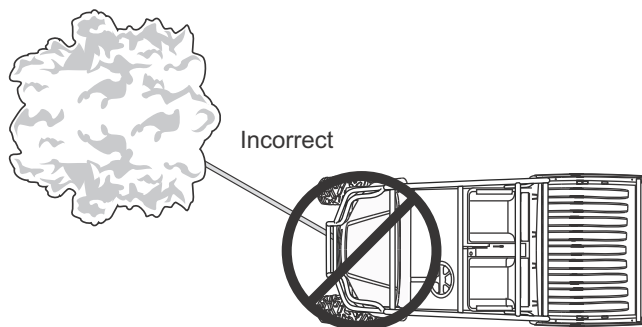

Incorrect

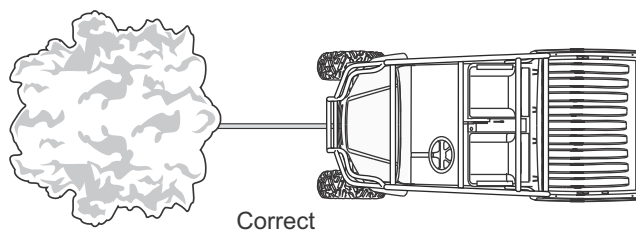

Correct

Do Not Pull at Angle

If the vehicle is being used as an anchor to winch a load, it should have the parking brake set and chocks installed on all wheels.

Never use the winch to lift people or other overhead loads.

Do not use the winch to secure loads. Use a tie down designed for the job.

Do not apply shock loads to the winch.

Do not attempt to modify or weld the winch.

MAINTENANCE

Read all of this manual to become thoroughly familiar with this vehicle. Pay particular attention to all Notices, Cautions, Warnings, and Dangers.

TITLE	PAGE NO.
VEHICLE CLEANING AND CARE	5-3
Vehicle Cleaning	5-3
ROUTINE MAINTENANCE	5-4
LIFTING THE VEHICLE	5-4
LIGHT BULB REPLACEMENT	5-5
Headlight Bulb Replacement	5-5
Taillight Bulb Replacement.....	5-5
WHEELS AND TIRES	5-5
Tire Repair.....	5-5
Wheel Installation.....	5-6
Unidirectional Tires	5-6
Wheel alignment	5-6
BRAKES	5-8
Master Cylinder.....	5-8
Bleeding Brake System.....	5-8
Parking Brake Adjustment.....	5-9
POWERTRAIN	5-9
AXLE	5-9
Checking the Lubricant Level.....	5-9
BATTERY CHARGING AND MAINTENANCE	5-10
Safety.....	5-10
Battery Disposal.....	5-10
Battery.....	5-10
Battery Maintenance	5-11
At Each Charging Cycle.....	5-11
Monthly.....	5-11
Temperature Affects Battery Capacity.....	5-12
Electrolyte Level and Water	5-12
Cleaning Batteries.....	5-14
Battery Removal and Installation	5-15
Prolonged Storage	5-15
Battery Charging	5-15
BATTERY TROUBLESHOOTING	5-16
HYDROMETER	5-16
Using A Hydrometer.....	5-17

MAINTENANCE

Read all of this manual to become thoroughly familiar with this vehicle. Pay particular attention to all Notices, Cautions, Warnings, and Dangers.

HARDWARE.....	5-18
CAPACITIES AND REPLACEMENT PARTS	5-18
PERIODIC SERVICE SCHEDULE.....	5-19

Read all of this manual to become thoroughly familiar with this vehicle. Pay particular attention to all Notices, Cautions, Warnings, and Dangers.

VEHICLE CLEANING AND CARE

Vehicle Cleaning

WARNING

To reduce the possibility of severe injury or vehicle damage, read and understand all instructions supplied by manufacturer of pressure washer.

CAUTION

When pressure washing exterior of vehicle, do not use pressure in excess of 700 psi. To reduce the possibility of cosmetic damage, do not use any abrasive or reactive solvents to clean plastic parts.

It is important that proper techniques and cleaning materials be used. Using excessive water pressure may cause severe injury to operator or bystander, damage to seals, plastics, seat material, body finish or electrical system. Do not use pressure in excess of 700 psi to wash exterior of vehicle.

Clean windshield with lots of water and a clean cloth. Minor scratches may be removed using a commercial plastic polish or Plexus[®] plastic cleaner available from the service parts department.

Normal cleaning of vinyl seats and plastic or rubber trim requires the use of a mild soap solution applied with a sponge or soft brush and wipe with a damp cloth.

Removal of oil, tar, asphalt, shoe polish, etc. will require the use of a commercially available vinyl/rubber cleaner.

The painted surfaces of the vehicle provide attractive appearance and durable protection. Frequent washing with lukewarm or cold water and mild detergent is required to preserve the painted surfaces.

Occasional cleaning and waxing with non-abrasive products designed for 'clear coat' automotive finishes will enhance the appearance and durability of the painted surfaces.

Corrosive materials used as fertilizers or for dust control can collect on the underbody of the vehicle. These materials will cause corrosion of underbody parts unless flushed occasionally with plain water. Thoroughly clean any areas where mud or other debris can collect. Sediment packed in closed areas should be loosened to ease its removal, taking care not to chip or otherwise damage paint.

MAINTENANCE

Read all of this manual to become thoroughly familiar with this vehicle. Pay particular attention to all Notices, Cautions, Warnings, and Dangers.

ROUTINE MAINTENANCE

Preventive maintenance, applied at recommended intervals, is the best guarantee for keeping the vehicle dependable.

This vehicle will give years of satisfactory service, providing it receives regular maintenance. Refer to the PERIODIC SERVICE SCHEDULE for appropriate service intervals.

LIFTING THE VEHICLE

Tool List	Qty
Floor jack.....	1
Jack stands	4
Wheel Chocks	4

WARNING

To reduce the possibility of severe injury or death from a vehicle falling from a jack:

Always place chocks in front and behind the wheels not being raised.

Be sure the vehicle is on a firm and level surface.

Never get under a vehicle while it is supported by a jack.

Use jack stands and test the stability of the vehicle on the stands.

Use extreme care since the vehicle is extremely unstable during the lifting process.

CAUTION

When lifting the vehicle, position the jacks and jack stands at the areas indicated.

Remove payload from vehicle before lifting. No person(s) should be in or on the vehicle while lifting.

To raise the entire vehicle, install the wheel chocks in front and behind each front wheel. Center the jack under the rear axle tube next to differential housing or under the skid plate. Raise the vehicle and position the jack stands under the frame where the leaf spring mounting bracket is welded to the frame.

Lower the jack and test the stability of the vehicle on the two jack stands.

Place the jack under the center front of the car just behind the bumper. Raise the vehicle and position the jack stands under the frame where the instrument panel support is attached to the frame.

Lower the jack and test the stability of the vehicle on all four jack stands. To raise only the front or rear of the vehicle, place the wheel chocks in front and behind the wheels that are not to be raised. The jack may be left under the center front of the frame while the front end of the vehicle is on the jackstands.

Lower the vehicle by reversing the lifting sequence.

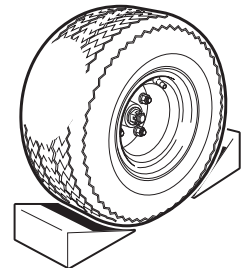
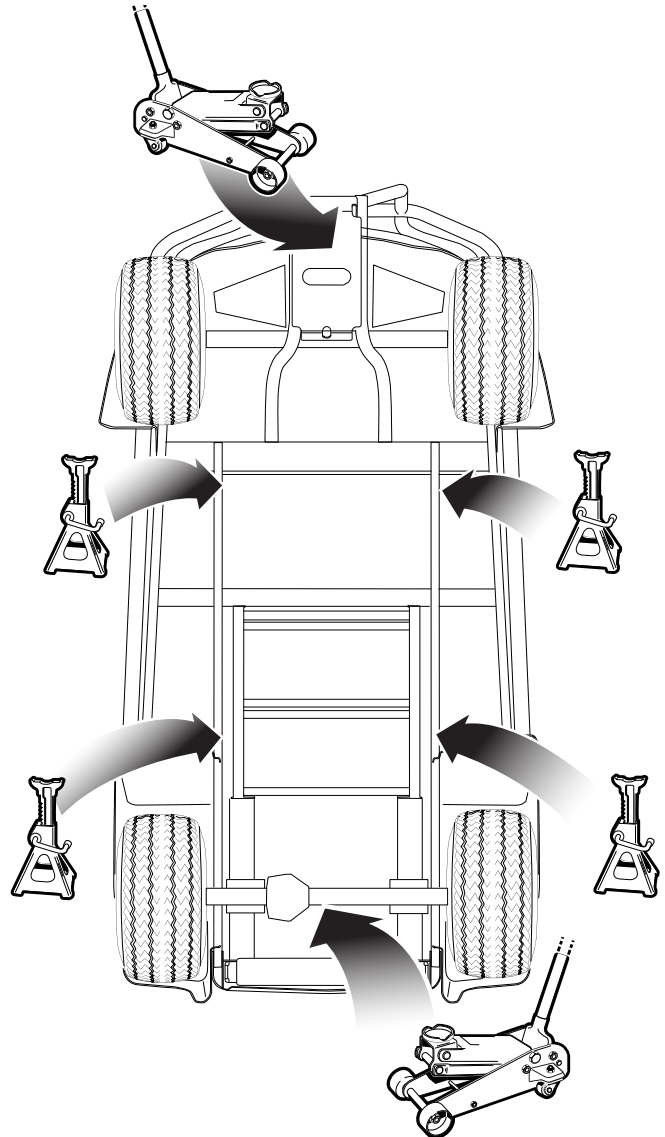

Read all of this manual to become thoroughly familiar with this vehicle. Pay particular attention to all Notices, Cautions, Warnings, and Dangers.

LIGHT BULB REPLACEMENT

CAUTION

To reduce the possibility of premature bulb failure, do not touch new bulbs with bare fingers. Use clean, dry tissue or paper towel to handle the glass portion of the bulb.

Headlight Bulb Replacement

Make sure that the vehicle key switch is in the OFF position and the key has been removed.

Locate the headlight bulb socket on the backside of the light assembly. Turn bulb socket a quarter turn counterclockwise to unlock. Pull out bulb and socket, remove old bulb from the socket. Insert new bulb in socket and position bulb socket into headlight housing and rotate socket a quarter turn clockwise to secure.

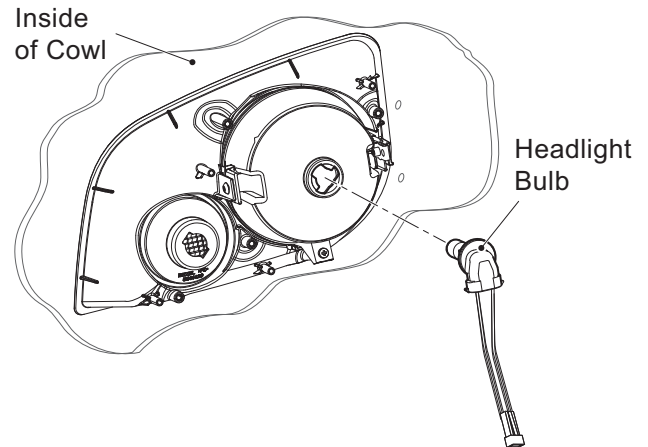

Taillight Bulb Replacement

Make sure that the vehicle key switch is in the OFF position and the key has been removed.

The taillight contains an LED light board rather than a light bulb, if the LEDs burn out the whole light will have to be replaced.

WHEELS AND TIRES

WARNING

A tire explosion can cause severe injury or death. Never exceed the inflation pressure rating on the tire sidewall.

To reduce the possibility of tire explosion, pressurize tire with small amounts of air applied intermittently to seat beads. Due to the low volume of the small tires, overinflation can occur in seconds. Never exceed the tire manufacturer's recommendation when seating a bead. Protect face and eyes from escaping air when removing a valve core.

Use caution when inflating tires. Overinflation could cause the tire to separate from the wheel or cause the tire to explode, either of which could cause severe injury.

To reduce the possibility of severe injury caused by a broken socket when removing wheels, use only sockets designed for impact wrench use.

Tire Repair

Tool List	Qty.	Tool List	Qty.
Lug Wrench, 3/4" or 17mm.....	1	Impact Socket, 3/4" or 17mm.....	1
Impact Wrench	1	Torque Wrench, ft. lbs.	1

Steel wheel rims will require the 3/4" lug wrench and aluminum wheel rims will require the 17mm lug wrench.

Generally, the most cost effective way to repair a flat tire resulting from a puncture in the tread portion is to use a commercial tire plug.

MAINTENANCE

Read all of this manual to become thoroughly familiar with this vehicle. Pay particular attention to all Notices, Cautions, Warnings, and Dangers.

If the tire is flat, raise vehicle and remove wheel. Refer to 'Lifting the Vehicle' for proper lifting procedure and safety information. Inflate tire to the maximum recommended pressure, immerse tire in water to locate the leak and mark the leak with chalk. Insert tire plug in accordance with manufacturer's specifications.

Use caution when inflating tires. Due to the low volume of the small tires, overinflation can occur in seconds. Overinflation could cause the tire to separate from the wheel or cause the tire to explode.

See GENERAL SPECIFICATIONS section for recommended tire inflation pressure. Under no condition should inflation pressure be higher than recommended on tire sidewall. All four tires should have the same pressure for optimum handling characteristics. Be sure to install the valve stem dust cap after checking or inflating. The vehicle is fitted with low volume tubeless tires mounted on one piece rims.

Wheel Installation

CAUTION

To reduce the possibility of component damage, do not tighten lug nuts to more than 85 ft. lbs. (115 Nm) torque.

NOTICE

It is important to follow the 'cross sequence' pattern when installing lug nuts. This will assure even seating of the wheel against the hub.

With the valve stem to the outside, mount the wheel onto the hub with lug nuts. Finger tighten the lug nuts (1) in a 'cross sequence' pattern. Tighten the lug nuts to 50 to 85 ft. lbs. (68 to 115 Nm) torque in 20 ft. lbs. (27 Nm) increments following the 'cross sequence' pattern.

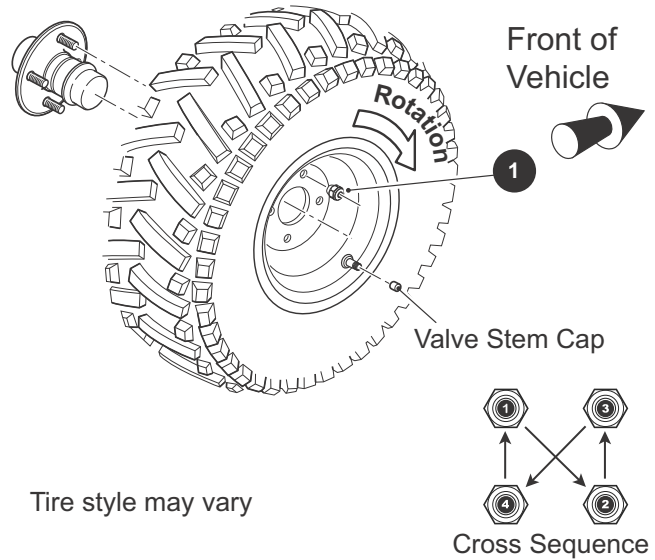

Unidirectional Tires

Unidirectional tires may be identified by a directional arrow on the sidewall. Be sure to position the wheel on the hub correctly with the arrow indicating the direction of rotation when moving forward.

WHEEL ALIGNMENT

Driving over rough terrain may cause mis-alignment of the wheels.

Wheel Alignment

Tool List	Qty.	Tool List	Qty.
Tape Measure	1	Open End Wrench, 12 mm	1
Open End Wrench, 17 mm.....	1	Open End Wrench, 19 mm	1

Park the buggy on a level surface, set the front wheels straight ahead. Turn the key switch to OFF, remove the key and set the parking brake.

With the buggy empty (no passengers or payload) measure the distance between the center of both the front and the rear sets of tires. Measure both in front and behind the front tire, keeping the tape measure parallel to the ground. The measurement behind the tires should be 1/4" less than the measurement taken at the front of the tires to produce a toe-out condition.

MAINTENANCE

Read all of this manual to become thoroughly familiar with this vehicle. Pay particular attention to all Notices, Cautions, Warnings, and Dangers.



Adjust both tie rods equally to obtain the correct toe-out. Hold tie rod (2) with an open end wrench, loosen the jam nut (1) and turn the adjustment shaft (3) to move the wheel in the desired direction.

Recheck the measurement at the front and at the rear of the front tires, if the 1/4" toe-out has been achieved tighten the lock nut (1) on each tie rod.

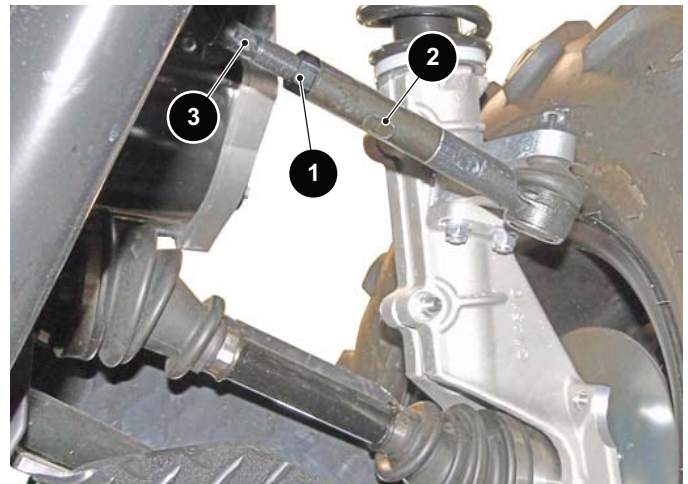

5

BRAKES

This vehicle is equipped with four wheel hydraulic disc brakes; the parking brake is hand operated. Check the fluid level at intervals specified in the PERIODIC SERVICE SCHEDULE; if fluid leaks are noticed or the brake pedal seems soft check the fluid level immediately. If the brake pedal is soft, the brake system should be bled to remove air from the brake lines. Instructions for bleeding the brake system are included in the vehicle repair manual.



Master Cylinder

The master cylinder is located behind the driver side front wheel, mounted to the frame. Before removing the reservoir cap, clean any dirt or debris from around the reservoir and cap.

Bleeding Brakes

Tool List	Qty.	Tool List	Qty.
Hose	A/R	Clean Container	1
Brake Fluid, DOT 3.....	A/R	Wrench, 1/4" box end	1

The hydraulic brake system must be free of air to operate properly. Air can enter the system when hydraulic parts are disconnected for servicing or replacement, or when the fluid level in the master cylinder reservoir is very low. Air in the system will give the brake pedal a spongy feeling upon application.

MAINTENANCE

Read all of this manual to become thoroughly familiar with this vehicle. Pay particular attention to all Notices, Cautions, Warnings, and Dangers.

NOTICE

An assistant will be necessary to perform this procedure.

1. Use a clean cloth to wipe off the master cylinder reservoir and wheel cylinder bleeder valves. Clean each fitting before opening to prevent contaminating the system.
2. Open the master cylinder reservoir and top off with standard automotive DOT 3 brake fluid.

WARNING

Never return brake fluid to the original container or reuse brake fluid due to the possibility of contamination by dirt, grease, moisture. Contaminated brake fluid could cause failure of the braking system. Dispose of brake fluid in accordance with Federal, state and local codes.

3. Attach a short length of clear hose to the caliper bleeder valve and insert the other end into a suitable clean container containing fresh, clean brake fluid.

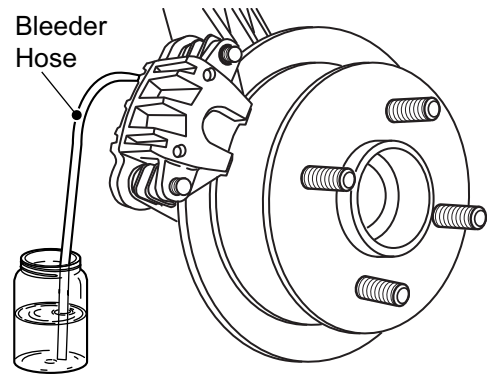

5 Check the fluid level in the master cylinder frequently during this operation to prevent air from entering the lines.

4. Starting with the passenger side rear brake, then driver side rear brake, passenger side front brake and driver side front brake last. Bleeding the brakes requires an assistant to pump the brake pedal and keep pressure on the pedal. Bleed the brakes using the following procedure:
 - a) Build pressure in the brake system, if possible, by slowly pumping the brake pedal.
 - b) Open the bleeder valve while an assistant holds pressure on the brake pedal as the pedal slowly goes through the full stroke.
 - c) Close the bleeder valve and have the assistant slowly release the brake pedal.
 - d) Repeat the process until no bubbles can be seen leaving the bleeder valve.
 - e) Close the valve and move to the next brake.

Parking Brake Adjustment

The floor mounted parking brake has an adjustment knob on the end of the handle. If the vehicle starts to roll when the parking brake is engaged on a hill, place one foot on the service brake pedal, turn the adjustment knob clockwise to increase tension on the brake, release the service brake and check to see if the parking brake is holding, repeat the process if necessary.



POWERTRAIN

WARNING

To reduce the possibility of severe injury or death from improper servicing techniques:

DO NOT attempt any type of servicing operations before reading all notes, cautions and warnings in this manual.

Never depress the accelerator pedal with drive wheels off the ground.

Any servicing requiring adjustments to be made to the powertrain while the motor is running must be made with all four drive wheels raised and vehicle properly supported on jack stands.

To reduce the possibility of motor damage, never operate vehicle at full throttle for more than 4 - 5 seconds while vehicle is in a 'no load' condition.

MAINTENANCE

Read all of this manual to become thoroughly familiar with this vehicle. Pay particular attention to all Notices, Cautions, Warnings, and Dangers.

Reduce the possibility of accidental starting by disconnecting battery at negative terminal before servicing.



Wear eye protection when working on the vehicle. Use extra care when working around batteries, or using solvents or compressed air.

To reduce the possibility of causing an electrical arc, which could result in a battery explosion, turn off all electrical loads from the battery before removing battery wires.

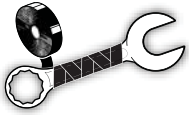

Wrap wrenches with vinyl tape to reduce the possibility of a dropped wrench 'shorting out' a battery, which could result in an explosion.

The electrolyte in a battery is an acid solution which can cause severe burns to the skin and eyes. Treat all electrolyte spills to the body and eyes with extended flushing with clear water. Contact a physician immediately.

Any electrolyte spills should be neutralized with a solution of 2 teaspoons (10 ml) sodium bicarbonate (baking soda) dissolved in 1 quart (1 liters) of water and flushed with water.

Aerosol containers of battery terminal protectant must be used with extreme care. Insulate metal container to reduce the possibility of can contacting battery terminals which could result in an explosion.

It is in the best interest of both vehicle owner and service technician to carefully follow the procedures recommended in this manual. Preventative maintenance, applied at recommended intervals, is the best guarantee for keeping the vehicle both dependable and economical.

This vehicle will give years of satisfactory service, providing it receives regular maintenance. Refer to the Periodic Service Schedule for appropriate service intervals.

CAUTION

To prolong vehicle life, some maintenance items must be serviced more frequently on vehicles used under severe driving conditions such as extreme temperatures, extreme dust/debris conditions, or frequent use with maximum load.

AXLE

Rear Axles

The only maintenance required for the first five years is the periodic inspection of the rear axle for lubricant leakage. Unless leakage is evident, the lubricant need only be replaced after five years. Refer to the Service and Repair Manual for the fluid replacement procedure.

Checking the Lubricant Level

Clean the area around the check/fill plug and remove the plug. The correct lubricant level is just below the bottom of the threaded hole. If lubricant is low, add lubricant as required. Add lubricant slowly until it starts to seep from the hole. Install the check/fill plug.

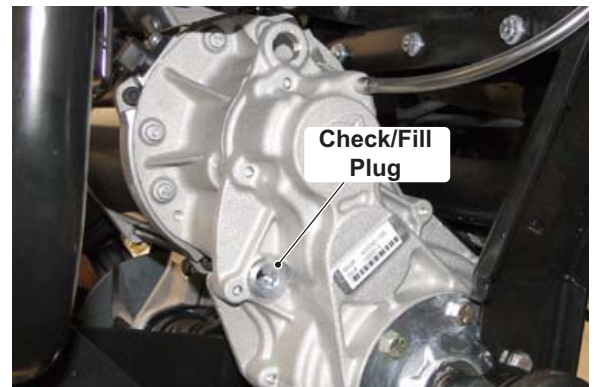

MAINTENANCE

Read all of this manual to become thoroughly familiar with this vehicle. Pay particular attention to all Notices, Cautions, Warnings, and Dangers.

BATTERY CHARGING AND MAINTENANCE

Safety

Always observe the following warnings when working on or near batteries.

WARNING

To prevent battery explosion that could result in severe personal injury or death, keep all smoking materials, open flames or sparks away from the batteries.

Hydrogen gas is formed when charging batteries. Do not charge batteries without adequate ventilation. A 4% concentration of hydrogen gas is explosive.

Be sure that the key switch is off and all electrical accessories are turned off before starting work on the vehicle.

Never disconnect a circuit under load at a battery terminal.

SAFETY FIRST



BEND KNEES
WHEN
LIFTING

Batteries are heavy. Use proper lifting techniques when moving them. Always lift the battery with a commercially available battery lifting device. Use care not to tip batteries when removing or installing them; spilled electrolyte can cause burns and damage.

The electrolyte in a storage battery is an acid solution which can cause severe burns to the skin and eyes. Treat all electrolyte spills to the body and eyes with extended flushing with clear water. Contact a physician immediately.

Always wear a safety shield or approved safety goggles when adding water or charging batteries.



Any electrolyte spills should be neutralized with a solution of 1/4 cup (60 ml) sodium bicarbonate (baking soda) dissolved in 1 1/2 gallons (6 liters) of water and flushed with water.

Overfilling batteries may result in electrolyte being spilled from the battery during the charge cycle. Expelled electrolyte may cause damage to the vehicle and storage facility.

Aerosol containers of battery terminal protectant must be used with extreme care. Insulate metal container to prevent can from contacting battery terminals which could result in an explosion.



Wrap wrenches with vinyl tape to prevent the possibility of a dropped wrench from shorting out a battery, which could result in an explosion and severe personal injury or death.

Battery Disposal

Lead-acid batteries are recyclable. Return whole scrap batteries to distributor, manufacturer or lead smelter for recycling. For neutralized spills, place residue in acid-resistant containers with absorbent material, sand or earth and dispose of in accordance with local, state and federal regulations for acid and lead compounds. Contact local and/or state environmental officials regarding disposal information.

Battery

A battery is defined as two dissimilar metals immersed in an acid. If the acid is absent or if the metals are not dissimilar, a battery has not been created. The batteries most commonly used in these vehicles are lead acid.

A battery does not store electricity, but is able to produce electricity as the result of a chemical reaction which releases stored chemical energy in the form of electrical energy. The chemical reaction takes place faster in warm conditions and

Read all of this manual to become thoroughly familiar with this vehicle. Pay particular attention to all Notices, Cautions, Warnings, and Dangers.

slower in cold conditions. Temperature is important when conducting tests on a battery and test results must be corrected to compensate for temperature differences.

As a battery ages, it still performs adequately except that its **capacity** is diminished. Capacity describes the time that a battery can continue to provide its design amperes from a full charge.

A battery has a maximum life, therefore good maintenance is designed to maximize the **available** life and reduce the factors that can reduce the life of the battery.

Battery Maintenance

Tool List	Qty.	Tool List	Qty.
Insulated Wrench, 9/16"	1	Battery Carrier	1
Hydrometer.....	1	Battery Maintenance Kit P/N 25587-G01	1
Battery Protective Spray.....	1		

Most of the battery set is located under the seat, one battery is located under the cowl. The single battery under the cowl is supplied with a battery fill system tube that is located in the passenger side glove box, the remaining batteries are accessed by raising and removing the seat bottom and the battery compartment cover.

At Each Charging Cycle



To reduce the possibility of fire, never attach a battery charger to a vehicle that is to be unattended beyond the normal charging cycle. Overcharging could cause damage to the vehicle batteries and result in extreme overheating. The charger should be checked after 24 hours and unplugged after the charge cycle is complete.

Before charging the batteries, inspect the plug of the battery charger and vehicle receptacle housing for dirt or debris. Charge the batteries after each day's use.

Monthly

- Inspect all wiring for fraying, loose terminations, corrosion or deterioration of insulation.
- Check that the electrolyte level is correct and add suitable water as required.
- Clean the batteries and wire terminations.
- Torque battery terminal nuts to 95 - 105 in. lbs. (11 - 12 Nm).
- Coat battery terminals with commercially available protectant.
- Replace all terminal covers.
- Replace battery compartment cover and note service date on chart.

MAINTENANCE

Read all of this manual to become thoroughly familiar with this vehicle. Pay particular attention to all Notices, Cautions, Warnings, and Dangers.

Temperature Affects Battery Capacity

Battery storage capacity is affected by the temperature; the colder it is, the less energy it is able to store; as temperature increases so does the storage capacity of the battery.

The ideal battery temperature for deep cycle batteries that are available today is 77°F (25°C). At 32°F (0°C) the storage capacity of the battery will be reduced by 20%, this means in cold weather the vehicle will not travel as far as it would in warm weather.

Electrolyte Level and Water

The correct level of the electrolyte is 1/2" (13 mm) above the plates in each cell.

This level will leave approximately 1/4" - 3/8" (6 - 10 mm) of space between the electrolyte and the vent tube. The electrolyte level is important since any portion of the plates exposed to air will be ruined beyond repair. Also avoid filling with too much water, which will result in electrolyte being forced out of the battery due to gassing and a decrease in volume of the electrolyte that results from the charging cycle.

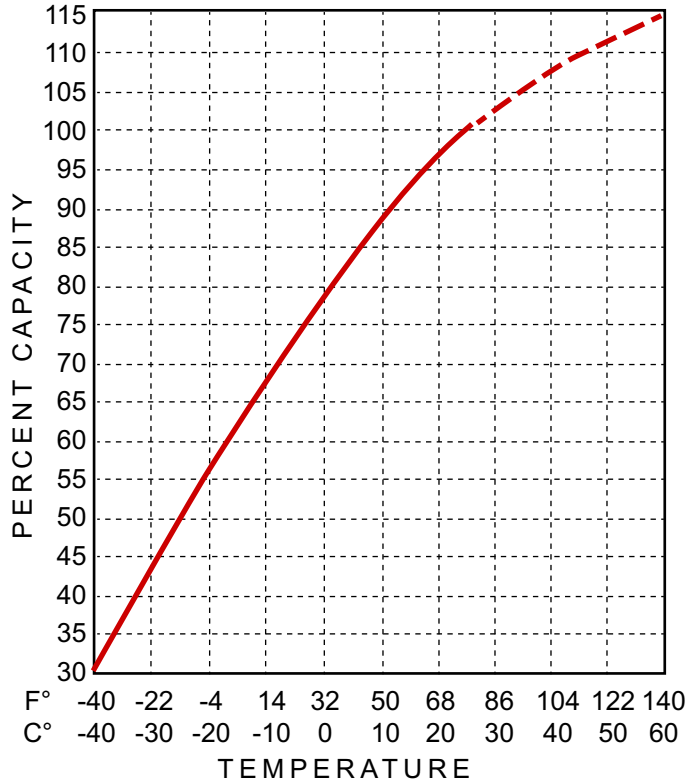

CAUTION

DO NOT overfill batteries. The charging cycle will expel electrolyte and result in component damage.

If the battery electrolyte level is too high, the electrolyte will block the vent tube and the gas will force it out of the vent tube and battery cap. The water will evaporate but the sulfuric acid will remain where it can damage vehicle components and the storage facility floor. Sulfuric acid loss will weaken the concentration of acid within the electrolyte and reduce the life of the battery.

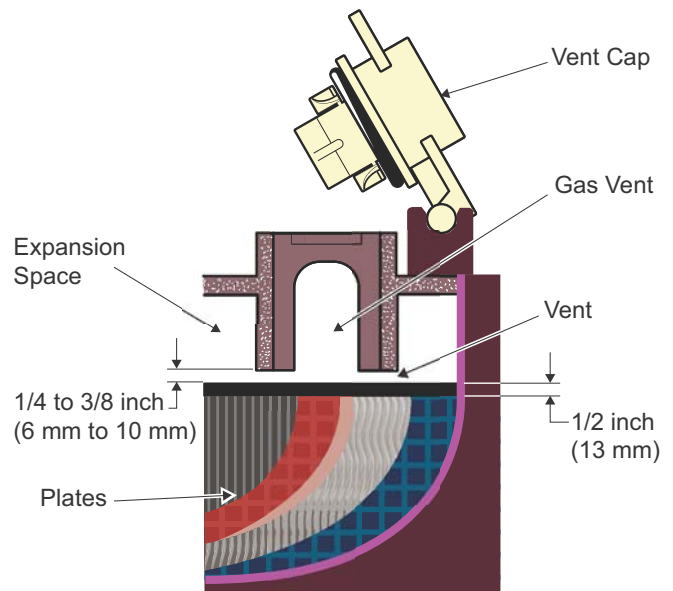

Electrolyte level should be at least 1/2" (13 mm) above the plates and 1/4" to 3/8" (6 to 10 mm) below vent.

MAINTENANCE

Read all of this manual to become thoroughly familiar with this vehicle. Pay particular attention to all Notices, Cautions, Warnings, and Dangers.

Over the life of the battery, a considerable amount of water is consumed. It is important that the water used be pure and free of contaminants that could reduce the life of the battery by reducing the chemical reaction. The water must be distilled or purified by an efficient filtration system. Even if the water is colorless, odorless, tasteless and fit for drinking, the water should be analyzed to see that it does not exceed the impurity levels specified in the table.

An Automatic Watering Gun or a Battery Watering Jug; available from many auto parts stores; may be used to fill the batteries, these watering devices are accurate, easy to use and allow for rapid filling. They also maintain the correct electrolyte level within the battery cells.

Impurity	Parts Per Million
Color	Clear
Suspended	Trace
Total Solids	100
Calcium & Magnesium Oxides	40
Iron	5
Ammonia	8
Organic & Volatile Matter	50
Nitrites	5
Nitrates	10
Chloride	5

Water Purity Table

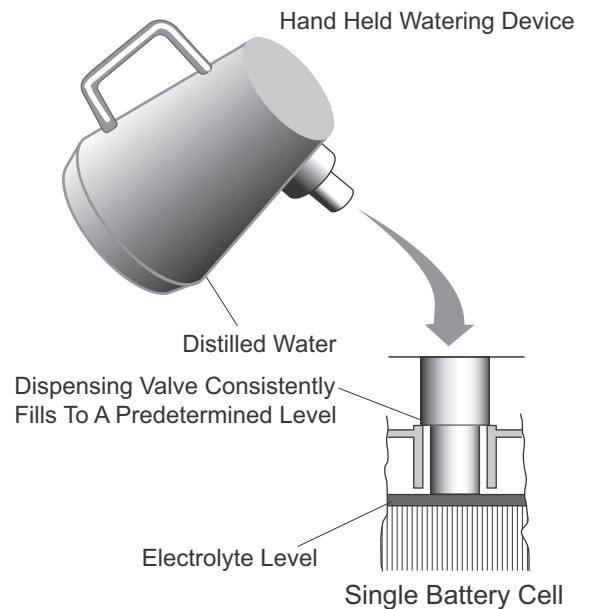
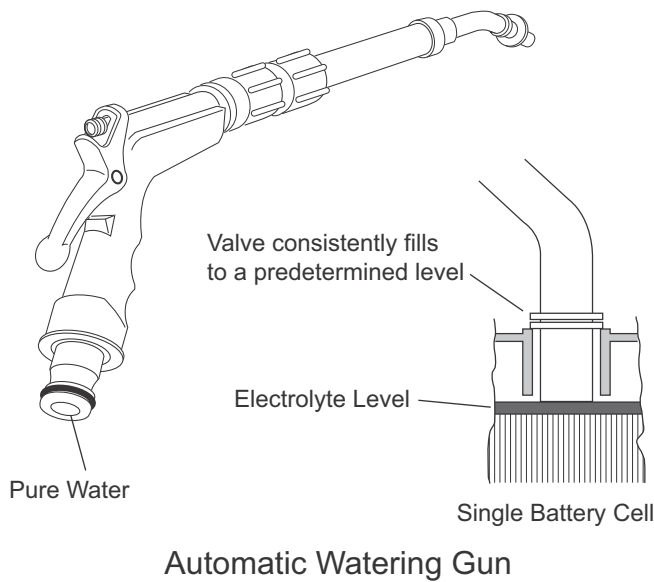

5

NOTICE

The watering device should only be used if the electrolyte level is less than 1/2" (13 mm) above top of plates...

WARNING

The electrolyte in a storage battery is an acid solution which can cause severe burns to the skin and eyes. Treat all electrolyte spills to the body and eyes with extended flushing with clear water. Contact a physician immediately.



Any electrolyte spills should be neutralized with a solution of 2 teaspoons (10 ml) sodium bicarbonate (baking soda) dissolved in 1 quart (1 liter) of water and flushed with water.

Always wear a safety shield or approved safety goggles when adding water or charging batteries.

MAINTENANCE

Read all of this manual to become thoroughly familiar with this vehicle. Pay particular attention to all Notices, Cautions, Warnings, and Dangers.

Cleaning Batteries

When cleaning the outside of the batteries and terminals, do not use a water hose without first spraying the batteries with a solution of baking soda (sodium bicarbonate) and water to neutralize any acid deposits. Use of a water hose without first neutralizing the acid will move the acid from the top of the batteries to another area of the vehicle or storage facility, where it will attack the metal structure or the concrete/asphalt floor. After hosing down the batteries, a residue will be left on the batteries, which is conductive and will contribute to the discharge of the batteries.

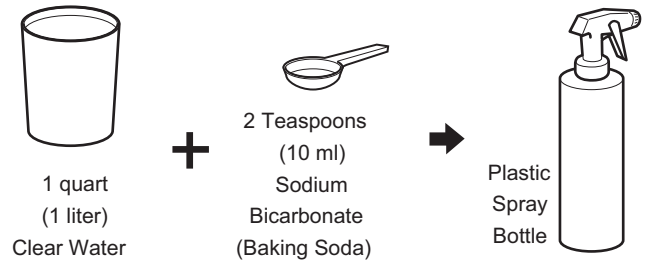

CAUTION

To prevent battery damage, be sure that all battery caps are tightly installed.

The correct cleaning technique is to spray the top and sides of the batteries with a solution of baking soda and water. This solution is best applied with a plastic spray bottle. The solution should consist of 2 teaspoons (10 ml) sodium bicarbonate (baking soda) dissolved in 1 quart (1 liter) of water. In addition to the batteries, special attention should be paid to metallic components adjacent to the batteries, these should also be sprayed with the baking soda solution.

Most of the battery set is located under the seat, one battery is located under the cowl. The single battery under the cowl is supplied with a battery fill system tube that is located in the passenger side glove box, to access the battery for cleaning remove the rivets from the access cover in the cowl and lift the cover. The remaining batteries are accessed by raising and removing the seat bottom and the battery cover.

Allow the solution to set for at least three minutes; use a soft bristle brush or cloth to wipe the tops of the batteries in order to remove any residue that could cause the self-discharge of the battery. Rinse the entire area with low pressure clear water.

Cleaning should take place once a month or more often under extreme conditions. After batteries are clean and dry, the terminals should be coated with a commercially available protectant. Aerosol containers of battery terminal protectant must be used with extreme care. Insulate the metal container to prevent the can from contacting the battery terminals.

Read all of this manual to become thoroughly familiar with this vehicle. Pay particular attention to all Notices, Cautions, Warnings, and Dangers.

Battery Removal and Installation

WARNING

Improper handling of high voltage wiring, batteries, or control systems could result in serious or fatal injury by electric shock. Only qualified technicians should repair or access high voltage wiring, battery packs, and associated systems.

To prevent battery explosion that could result in severe personal injury or death, extreme care must be used with aerosol containers of battery terminal protectant. Insulate the metal container to prevent the metal can from contacting battery terminals, which could result in an explosion.

CAUTION

If the batteries are replaced, make sure they are the exact type and model originally supplied with the vehicle. Failure to follow this caution can result in damage to the vehicle's electrical system.

Before disconnecting the batteries set the RUN - MAINTENANCE/STORAGE switch to MAINTENANCE/STORAGE

Prolonged Storage

During periods of storage, the batteries will need attention to keep them maintained and prevent discharge.

In winter conditions, the battery must be fully charged to prevent the possibility of freezing. A fully charged battery will not freeze in temperatures above -75°F (-60°C). Although the chemical reaction is slowed in cold temperatures, the battery must be stored fully charged, and disconnected from any circuit that could discharge the battery. The controller should be disconnected from the batteries by setting the RUN-MAINTENANCE/STORAGE switch, located under the seat on the passenger side, to the MAINTENANCE/STORAGE position. The batteries must be cleaned and all deposits neutralized and removed from the battery case to prevent self discharge.

The battery charger may be left connected to the vehicle to maintain a full charge on the batteries, provided the charger is plugged into an active electrical source. If power to the electrical source is disconnected or interrupted the battery charger will continue to check the charge on the battery pack, this will draw power from the battery pack and eventually drain the batteries if power is not restored in a timely manner.

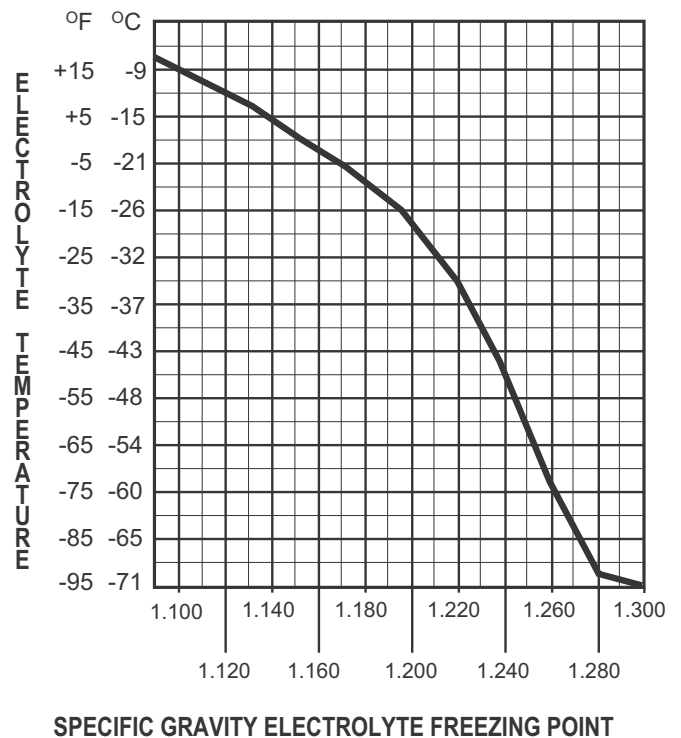
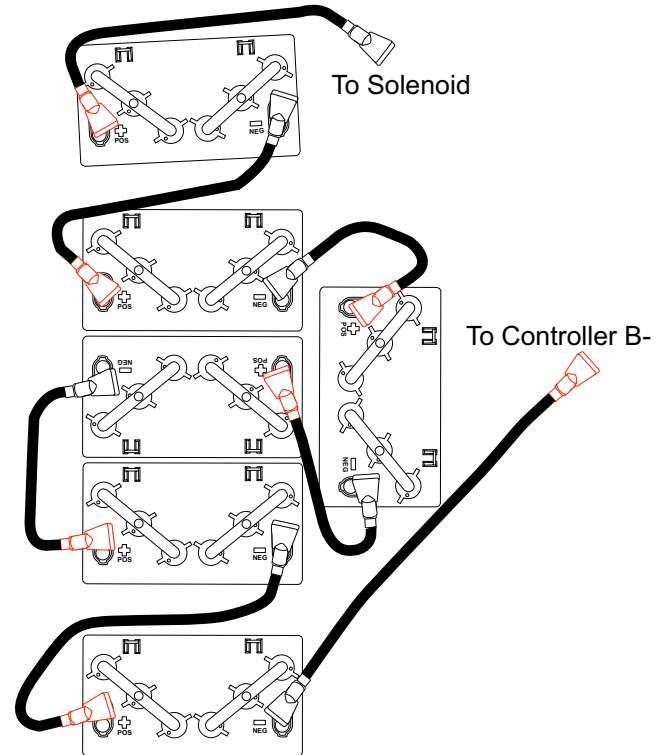

MAINTENANCE

Read all of this manual to become thoroughly familiar with this vehicle. Pay particular attention to all Notices, Cautions, Warnings, and Dangers.

Battery Charging

The battery charger is designed to fully charge the battery set. If the batteries are severely deep cycled, some automatic battery chargers contain an electronic module that may not activate and the battery charger will not function. Automatic chargers will determine the correct duration of charge to the battery set and will shut off when the battery set is fully charged. Always refer to the instructions of the specific charger used.

Before charging, the following should be observed:



CAUTION

Do not overfill batteries. The charging cycle will expel electrolyte and result in component damage.

- The electrolyte level in all cells must be at the recommended level and cover the plates.
- The charging must take place in an area that is well ventilated and capable of removing the hydrogen gas that is generated by the charging process. A **minimum** of five air exchanges per hour is recommended.
- The charging connector components must be in good condition and free from dirt or debris.
- The charger connector must be fully inserted into the vehicle receptacle.
- The charger connector/cord set is protected from damage and is located in an area to prevent injury that may result from personnel running over or tripping over the cord set.
- The charger is automatically turned off during the connect/disconnect cycle and therefore no electrical arc is generated at the DC plug/receptacle contacts.

BATTERY TROUBLESHOOTING

In general, troubleshooting will be done for two distinct reasons. First, a battery that performs poorly and is outside of the manufacturer's specification should be identified in order to replace it under the terms of the manufacturer's warranty. Different manufacturers have different requirements. Consult the battery manufacturer or the manufacturer's representative for specific requirements.

The second reason is to determine why a particular vehicle does not perform adequately. Performance problems may result in a vehicle that runs slowly or in a vehicle that is unable to operate for the time required.

A new battery must **mature** before it will develop its maximum capacity. Maturing may take up to 100 charge/discharge cycles. After the maturing phase, the older a battery gets, the lower the capacity. The only way to determine the capacity of a battery is to perform a load test using a discharge machine following manufacturer's recommendations.

A cost effective way to identify a poorly performing battery is to use a hydrometer to identify a battery in a set with a lower than normal specific gravity. Once the particular cell or cells that are the problem are identified, the suspect battery can be removed and replaced. At this point there is nothing that can be done to salvage the battery; however, the individual battery should be replaced with a good battery of the same brand, type and approximate age.

HYDROMETER

A hydrometer is used to test the state of charge of a battery cell. This is performed by measuring the density of the electrolyte, which is accomplished by measuring the specific gravity of the electrolyte. The greater the concentration of sulfuric acid, the more dense the electrolyte becomes. The higher the density, the higher the state of charge.

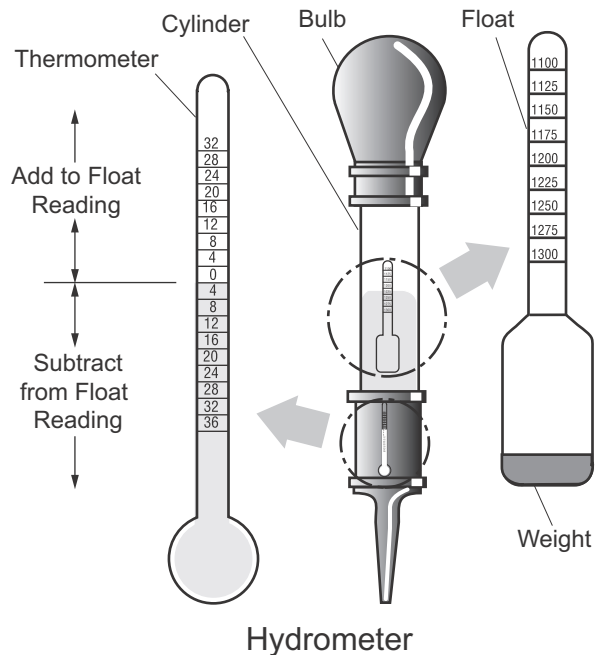

Read all of this manual to become thoroughly familiar with this vehicle. Pay particular attention to all Notices, Cautions, Warnings, and Dangers.

WARNING

To prevent battery explosion that could result in severe personal injury or death, never insert a metal thermometer into a battery. Use a hydrometer with a built in thermometer that is designed for testing batteries.

Specific gravity is the measurement of a liquid that is compared to a baseline. The baseline is water which is assigned a base number of 1.000. The concentration of sulfuric acid to water in a new golf car battery is 1.280 which means that the electrolyte weighs 1.280 times the weight of the same volume of water. A fully charged battery will test at 1.275 - 1.280 while a discharged battery will read in the 1.140 range.

NOTICE

Do not perform a hydrometer test on a battery that has just been watered. The battery must go through at least one charge and discharge cycle in order to permit the water to adequately mix with the electrolyte.

The temperature of the **electrolyte** is important since the hydrometer reading must be corrected to 80° F (27° C). High quality hydrometers are equipped with an internal thermometer that will measure the temperature of the electrolyte and will include a conversion scale to correct the float reading. It is important to recognize that the electrolyte temperature is significantly different from the ambient temperature if the vehicle has been operated.

Using A Hydrometer

1. Draw electrolyte into the hydrometer several times to permit the thermometer to adjust to the electrolyte temperature and note the reading. Examine the color of the electrolyte. A brown or gray coloration indicates a problem with the battery and is a sign that the battery is nearing the end of its life.
2. Draw the minimum quantity of electrolyte into the hydrometer to permit the float to float freely without contacting the top or bottom of the cylinder.
3. Hold the hydrometer in a vertical position at eye level and note the reading where the electrolyte meets the scale on the float.
4. Add or subtract four points (.004) to the reading for every 10° F (6° C) the electrolyte temperature is above or below 80° F (27° C). Adjust the reading to conform with the electrolyte temperature, e.g., if the reading indicates a specific gravity of 1.250 and the electrolyte temperature is 90° F (32° C), add four points (.004) to the 1.250 which gives a corrected reading of 1.254. Similarly if the temperature was 70° F (21° C), subtract four points (.004) from the 1.250 to give a corrected reading of 1.246.
5. Test each cell and note the readings (corrected to 80° F or 27° C). A variation of fifty points between any two cell readings (example 1.250 - 1.200) indicates a problem with the low reading cell(s).

As a battery ages the specific gravity of the electrolyte will decrease at full charge. This is not a reason to replace the battery providing all cells are within fifty points of each other.

ELECTROLYTE TEMPERATURE

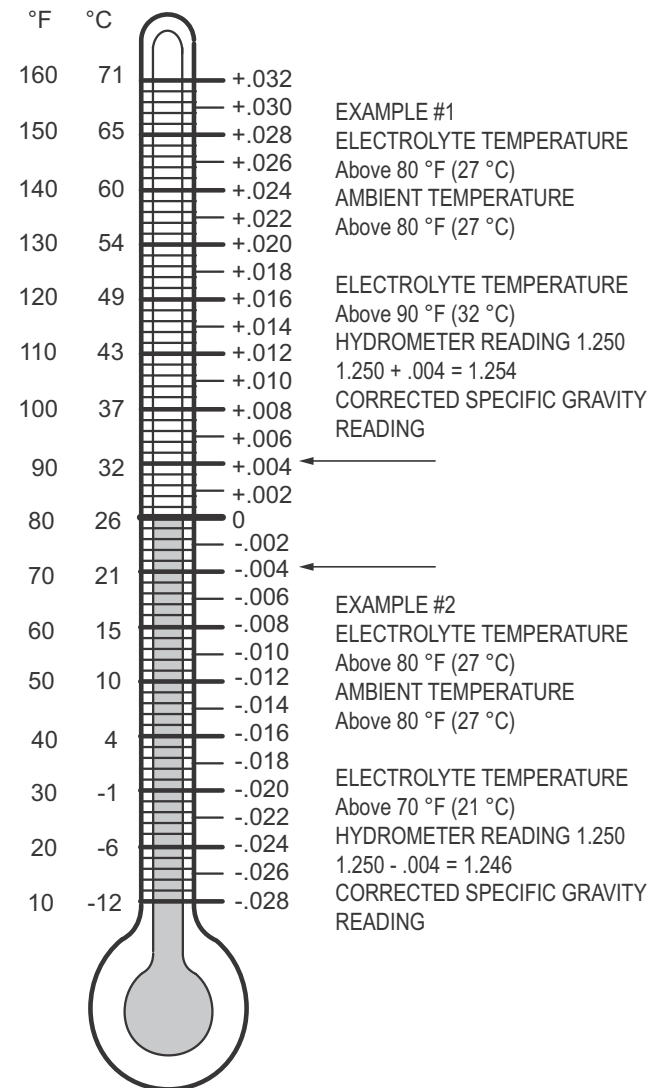

Hydrometer Temperature Correction

MAINTENANCE







Read all of this manual to become thoroughly familiar with this vehicle. Pay particular attention to all Notices, Cautions, Warnings, and Dangers.

Since the hydrometer test is in response to a vehicle exhibiting a performance problem, the vehicle should be recharged and the test repeated. If the results indicate a weak cell, the battery or batteries should be removed and replaced with a good battery of the same brand, type and approximate age.

HARDWARE

Periodically, the vehicle should be inspected for loose fasteners. Use care when tightening fasteners, refer to the Technician's Repair and Service Manual for specific torque values.

Generally, three classes of standard hardware and two classes of metric hardware are used in the vehicle. Grade 5 hardware can be identified by the three marks on the hex head and grade 8 hardware is identified by six marks on the head. metric hardware is marked on the head with 8.8 or 10.9. Unmarked hardware is Grade 2.

ALL TORQUE FIGURES ARE IN FT. LBS. (Nm)										
Unless otherwise noted in text, tighten all hardware in accordance with this chart.										
This chart specifies 'lubricated' torque figures. Fasteners that are plated or lubricated when installed are considered 'wet' and require approximately 80% of the torque required for 'dry' fasteners.										
BOLT SIZE	1/4"	5/16"	3/8"	7/16"	1/2"	9/16"	5/8"	3/4"	7/8"	1"
Grade 2 	4 (5)	8 (11)	15 (20)	24 (33)	35 (47)	55 (75)	75 (102)	130 (176)	125 (169)	190 (258)
Grade 5 	6 (8)	13 (18)	23 (31)	35 (47)	55 (75)	80 (108)	110 (149)	200 (271)	320 (434)	480 (651)
Grade 8 	6 (8)	18 (24)	35 (47)	55 (75)	80 (108)	110 (149)	170 (230)	280 (380)	460 (624)	680 (922)
BOLT SIZE	M4	M5	M6	M8	M10	M12	M14			
Class 5.8  (Grade 2)	1 (2)	2 (3)	4 (6)	10 (14)	20 (27)	35 (47)	55 (76.4)			
Class 8.8  (Grade 5)	2 (3)	4 (6)	7 (10)	18 (24)	35 (47)	61 (83)	97 (131)			
Class 10.9  (Grade 8)	3 (4)	6 (8)	10 (14)	25 (34)	49 (66)	86 (117)	136 (184)			

Torque Specifications and Bolt Grades

CAPACITIES AND REPLACEMENT PARTS

CAPACITIES	
Front Axle Oil	13.8 oz. 90 wt. gear oil
Rear Axle Oil	13.8 oz. 90 wt. gear oil
Brake Fluid	DOT 3

REPLACEMENT PART NUMBERS	
Headlight Bulb	619100
LED Headlight Bulb	619101
ATC type Fuse 10 Amp	35212G07
ATC type Fuse 15 Amp	35212G01
ATC type Fuse 20 Amp	35212G02

MAINTENANCE

Read all of this manual to become thoroughly familiar with this vehicle. Pay particular attention to all Notices, Cautions, Warnings, and Dangers.

PERIODIC SERVICE SCHEDULE

✓ - CHECK C&A - CHECK & ADJUST CL - CLEAN R - REPLACE

REMARKS	before each use DAILY	250 miles/415 kms MONTHLY	750 miles/1250 kms QUARTERLY	1500miles/2500 kms SEMI-ANNUAL	3000miles/5000 kms ANNUAL	REPLACE AFTER
Tires - pressure, condition of tires and rims	✓	✓	✓	✓	✓	
Hardware - loose or missing	✓	✓	✓	✓	✓	
Overall Vehicle Condition	✓	✓	✓	✓	✓	
Batteries - state of charge, condition, loose terminals, corrosion, hold down and hardware		✓	CL	CL	CL	
Batteries* - check electrolyte level, fill after charging if required (if plates are exposed before charging add only enough water to cover any exposed plates and fill after charging)		C&A	C&A	C&A	C&A	
Brakes - check fluid level in master cylinder		✓	✓	✓	✓	3000 mi/5000 km
Brakes - smooth operation of pedal, stopping distance	✓	✓	✓	✓	✓	
Park Brake - does brake hold on a hill		C&A	C&A	C&A	C&A	
Accelerator - smooth operation	✓	✓	✓	✓	✓	
Wiring - loose connections, broken or missing insulation		✓	✓	✓	✓	
Charger Receptacle - inspect and clean receptacle at each charge		CL	CL	CL	CL	
Steering Assembly - excessive play, loose or missing hardware		✓	✓	✓	✓	
Tie Rods - excessive play, bent rods, loose or missing hardware		✓	✓	✓	✓	
Rear Axle - oil leakage, noise, loose or missing hardware		✓	✓	✓	✓	
Rear Axle - drain and replace fluid						5000 mi/8000 km
Front Suspension - strut oil leakage, excessive play in hubs or king-pins, worn bushings, loose or missing hardware		✓	✓	✓	✓	
Front Wheel Alignment - unusual tire wear			C&A	C&A	C&A	
Rear Suspension - strut oil leakage, worn bushings, loose or missing hardware			✓	✓	✓	
*Use only distilled or purified water that is free of contaminants to fill batteries.						

5

NOTE: Some maintenance items must be serviced more frequently on vehicles used under severe driving conditions.



Bad Boy Buggies
1451 Marvin Griffin Road, Augusta,
Georgia USA 30906-3852

TO CONTACT US

E-mail: info@badboybuggies.com
For parts and repair contact your local dealer.
To locate a local dealer please go online to our website:
www.BADBOYBUGGIES.COM

Certified ISO 9001 / ISO 14001 by



©2011 E-Z-GO Division of Textron Inc.
This manual may not be reproduced in whole or
in part without the express permission of
E-Z-GO Division of Textron Inc.
Technical Communications Department