



REPAIR AND SERVICE MANUAL



Table of Contents

Purpose	1
Golf Cart Preventive Maintenance and Repair Program.....	2
Review I.....	3
Warranty	4
Safety info.....	9
Pre-Operations.....	12
Important decals.....	14
Operation instructions.....	19
Brake and Accelerator	19
Key switch and indicators	21
Dashboard functions.....	22
Speedometer.....	23
Light and Horn Control.....	26
On board charger.....	27
Battery.....	34
Steering column &Steering wheel.....	37
Motor & Rear axle.....	38
LED turning signal and brake lights.....	39
Vehicle tires.....	40
Periodic maintenance schedule chart	41
Maintenance tools	42
Vehicle maintenance and adjustment	44
Chassis	45
Front suspension	47
Rear axle& Brake.....	49
Tires.....	51
Battery	51
Motor.....	53

Other electric components	55
Vehicle malfunctions	56
How to eliminate malfunctions	56
Electronic part.....	56
System diagram.....	57
1232SE AC System	57
How can you test electronic components... ..	59
Controller panel.....	60
Accelerator box... ..	61
Motor.....	63
Speed sensor... ..	65
How to work on wiring harness and connectors... ..	66
How to use handheld programmer	67
Vehicle controller programming sheet.....	84
1232SE AC controller programming sheet... ..	84
How to troubleshoot electric system.....	86
Vehicle velocity dropping... ..	87
Vehicle does not run	89
Vehicle jerks while on run... ..	91
Vehicle has inconsistent power output	93
Vehicle has inconsistent power in high speed... ..	95
Vehicle stops when blow the horn or other devices	97
Vehicle stops and goes.....	98
Speed sensor can not work	99
Motor has a big sound... ..	100
Motor brunt down	101
Vehicle lose range severely	102
Solenoid works intermittently	103
Charger indication LED flashing in red.....	104
Charger can not charge battery	105
DC-DC converter not working.....	106
Rear LED taillights break down	108

Front light bulb break down	109
Switch assembly not functional... ..	110
Accelerator pedal locking.....	111
Battery relocation... ..	112
Mechanical part... ..	113
How to eliminate the mechanical malfunctions.....	114
Vehicle has wrong wheel camber.....	115
Vehicle has stiff steering	116
Vehicle has stiff shock absorbing ability.....	117
Parking brake to hard to lock or unlock.....	118
Steering wheel shakes.....	119
Steering got stuck when turn to certain angle	120
Brake pedal or throttle sticky or stuck... ..	121
Vehicle has bad braking ability... ..	124
Brake shoes glazed... ..	126
Vehicle brake damaged or sticky.. ..	127
Vehicle has unequal braking... ..	128
Noisy rear axle... ..	129
Vehicle has unevenly worn out tires	130
Vehicle Storage	133
SPECIFICATION.. ..	135
APPENDIX 1: The programming data sheet.. ..	
APPENDIX 2: The troubleshooting chart.. ..	

EVOLUTION DECLARATION

EVOLUTION corporation mainly dealing with five types of the electric vehicles, such as electric golf car, shuttle bus, utility cart, engineer and transportation cart, and special electric car. Our electric car is environment-friendly and suitable for use in course, hotels and other business places. All the key components are imported from well known companies. The whole car it is with new fashion design. Stable performance, flexible control, and comfortable driving. Our electric car be used as people mover or utility car in vacation villages, villa areas, resort hotels private residential areas, tourist scenic spots, or any other place where this type of electric car is allowed. The warranty papers is to standardize the after-sale service for export vehicle, settle the claims efficiently and improve our after-sale service.

EVOLUTION electric vehicle corporation dedicate in electric vehicles manufacture since 2006, EVOLUTION customers scatter all over the world, EVOLUTION electric vehicle corporation promise any client who bought EVOLUTION vehicles, EVOLUTION technicians will be always be ready for fix problems for you. We provide splendid quality of after sale service.

For more warranty information please see limited warranty papers, that customers receive while purchase EVOLUTION vehicles.

Purpose

The purpose of this training manual is:

to train you in the knowledge, skills, and techniques necessary to properly maintain & repair the Club's golf cart fleet; to teach you how to document golf cart servicing and lubrication; and to establish procedures to track and monitor repairs to golf carts.

Responsibilities

It is the responsibility of the Head Golf Professional to ensure that all preventive maintenance is performed according to schedule. Further, it is his responsibility to ensure that cart attendants are properly trained to perform routine preventive maintenance checks and servicing according to schedule.

It is the Facility Manager's responsibility to:

monitor the performance of routine preventive maintenance, assist the Head Golf Professional in establishing and maintaining the Golf Cart Preventive Maintenance Program, and provide expert assistance and advice to the Head Golf Professional and cart attendants in dealing with specific maintenance and repair problems with golf carts. It is the cart attendants' responsibility to conscientiously perform all specified checks and services called for in the Golf Cart Preventive Maintenance Program and to report problems to the EVOLUTION ELECTRIC VEHICLE Professional in a timely manner.

Golf Cart Preventive Maintenance and Repair Program

The useful life of golf carts can be maintained and even extended by proper preventive maintenance. Inoperative or unserviceable golf carts must be repaired in a timely manner. Golf Cart Preventive Maintenance Program.

The Golf Cart Preventive Maintenance Program is a comprehensive series of checks and services to properly maintain golf carts in good working order.

The program entails six basic components:

- Battery Care
- Battery Charging
- Pre-Operation Safety Check
- Periodic Service Schedule
- Periodic Lubrication Schedule
- Golf Cart Cleaning and Detailing

Review I

Give two of the purposes of this training manual.

- 1.
- 2.

What are your responsibilities regarding this training material?

- 1.
- 2.

List the six components of the Preventive Maintenance and Repair Program.

- 1.
- 2.
- 3.
- 4.
- 5.
- 6.

Which three forms are maintained for each golf cart and what is the purpose of each?

- 1.
- 2.
- 3.

What form is used to report golf carts needing repair?

CLARIFICATIONS:

All warranty claims shall be filed via email on a Evolution ELECTRIC VEHICLES warranty claim form with pictures when requested as well as all sublet jobs receipts prior to authorization to do warranty repairs and sometimes a RMA (return materials authorization) claim form may also be needed which will be supplied prior to any warranty work performed by a duly authorized Dealer, and Evolution ELECTRIC VEHICLES has 30 days to agree to or to decline the warranty.

All warranty parts will be paid for in advance and a credit will be issued at the time Evolution ELECTRIC VEHICLES has authorized such warranty claim and received defective part(s) back to our warranty service department for final evaluation. It is Evolution ELECTRIC VEHICLES decision whether the parts need to be returned on an individual basis. All required parts should be returned to Evolution ELECTRIC VEHICLES within 10 working days from time the claim is filed. Dealer(s) are responsible for the freight/shipping cost to Evolution ELECTRIC VEHICLES or to the parts warranty division if part is found not to be defective. Evolution ELECTRIC VEHICLES will be responsible for the shipping cost of all warranty parts to and from the dealer's location once the claim is approved. Shipping is standard delivery. NO OVER NIGHT unless paid for by dealers and upon his (her) request.

This warranty is effective for 2014 models and up. Any changes should be informed three months earlier.

EXCLUSIONS: Specifically excluded from any Evolution ELECTRIC VEHICLES warranty are adjustments/repairs made due to normal wear beyond the first Ninety (90) days, routine maintenance items, cosmetic deterioration, weather deterioration and electrical components which are susceptible to fluctuations in current which is beyond the control of Evolution ELECTRIC VEHICLES. This warranty also does not apply to Acts of God like power surges or other events over which EVOLUTIONELECTRIC VEHICLES has no control. Transportation charges for warranty service are excluded from this warranty and all replaced parts shall become property of Evolution ELECTRIC VEHICLES unless released by Evolution ELECTRIC VEHICLES acknowledgement in email or writing. Any parts repaired/replaced under this warranty shall be warranted for a period of ninety (90) days or for the remainder of the original warranty, whichever is greater. This warranty excludes tires, which are warranted by their respective manufacturer.

REMEDY: The sole remedy under this warranty and Evolution ELECTRIC VEHICLES is the obligation in the event of a defect in the vehicle/battery chargers is that Evolution ELECTRIC VEHICLES will, at its sole option, repair or replace any defective parts. This remedy precludes all other remedies including any lawsuits, claims or other proceedings alleging strict liability, negligence of contract or any

cause of action. Evolution ELECTRIC VEHICLES reserves the right to improve or change the design of any Evolution ELECTRIC VEHICLES vehicle or battery charger without assuming any responsibility to modify previously manufactured vehicles.

DISCLAIMER: This warranty is made in lieu of all other warranties, implied or expressed, including any warranty of merchantability or fitness for a particular purpose. Evolution ELECTRIC VEHICLES further disclaims all liability for incidental, exemplary, punitive or consequential damages; to include but not limited to, personal injury or property damage arising from any defect in the Evolution ELECTRIC VEHICLES vehicle or battery charger.

No agent, employee or representative of Evolution ELECTRIC VEHICLES or Evolution ELECTRIC VEHICLES or any person has authority to bind Evolution ELECTRIC VEHICLES or Evolution ELECTRIC VEHICLES to any other agreement, representation or warranty concerning the goods sold under this warranty. Some states do not allow limitation on how long an implied warranty lasts or the exclusion or limitation of incidental or consequential damages, so the above limitations may not apply to you. This warranty gives you specific legal rights, and you may also have other rights, which vary from state to state.

Products supplied to dealer by Evolution ELECTRIC VEHICLES are warranted only in accordance with Evolution ELECTRIC VEHICLES written warranty to consumers, which is supplied to dealer for distribution to dealer's customers and which may be amended or modified at Evolution ELECTRIC VEHICLES discretion. **OTHER THAN THE WARRANTY CONTAINED IN EVOLUTIONELECTRIC VEHICLES WRITTEN WARRANTY OR AS REQUIRED BY LAW, Evolution ELECTRIC VEHICLES DISCLAIMS ANY OTHER WARRANTY, EXPRESS OR IMPLIED, INCLUDING BUT NOT BY WAY OF LIMITATION, THE WARRANTIES OF MERCHANTABILITY AND FITNESS FOR ANY PARTICULAR PURPOSE. Evolution ELECTRIC VEHICLES DISCLAIMS ANY LIABILITY FOR INCIDENTAL, SPECIAL OR CONSEQUENTIAL DAMAGES OR COMMERCIAL LOSSES SUFFERED BY DEALER, ITS CUSTOMERS OR ANY THIRD PARTY,** except as provided under state law. This warranty expressly excludes any and all products that Dealer has altered, changed or modified in terms of form, features, function or configuration after said Products are supplied by Evolution ELECTRIC VEHICLES in their original form. Dealer shall show customers any applicable EVOLUTIONELECTRIC VEHICLES warranty prior to sale of the Products and will furnish customers a copy of any applicable EVOLUTIONELECTRIC VEHICLES warranty at the time of sale. Dealer shall not give, or purport to give any additional or different warranty to customers on behalf of Evolution ELECTRIC VEHICLES, other than the applicable written warranty of EVOLUTIONELECTRIC VEHICLES for the Products.

Dealer acknowledges the importance of their service department in providing to owners of the Products prompt and skilled warranty service and the need to comply with all laws relating to warranty service. Dealer shall give immediate service to such warranty requests. Dealer shall submit complete and accurate claims to EVOLUTIONELECTRIC VEHICLES for reimbursement on their account for parts and labor used in performing warranty service on warranty claim forms of EVOLUTIONELECTRIC VEHICLES with all information required therein; and EVOLUTIONELECTRIC VEHICLES shall reimburse Dealer on their account for such parts and labor, in accordance with the effective schedules and rates applicable to Dealer. Dealer shall keep and retain complete and accurate records and documents supporting such claims, in the event of the discovery of any improper claim or payment. EVOLUTIONELECTRIC VEHICLES may charge back to Dealer all payments or credits plus interest thereon made by EVOLUTIONELECTRIC VEHICLES to Dealer pursuant to such claims or otherwise, as well as the costs to EVOLUTIONELECTRIC VEHICLES for such audit and the recovery of such payments or credit.

ASSISTANCE AND PROTECTION In the event any warranty claim arises that dealer is unable to perform, EVOLUTIONELECTRIC VEHICLES should be promptly notified by dealer and be provided the details of the claim and EVOLUTIONELECTRIC VEHICLES shall use reasonable efforts to resolve such claim. EVOLUTIONELECTRIC VEHICLES will have service representatives available for Dealer to CONSULT WITH, if necessary, in connection with service problems. EVOLUTIONELECTRIC VEHICLES is relying upon dealer's assurance that it has capable personal and service techs qualified to perform service obligations for the products. Dealer agrees to fully protect EVOLUTIONELECTRIC VEHICLES from any claims, liability or loss that may result from a failure of Dealer to properly perform service for the Products as required hereunder or under applicable law. EVOLUTIONELECTRIC VEHICLES or EVOLUTIONELECTRIC VEHICLES is not the dealers or Distributors service department and are there to assist as needed only.

WARNING: Any modification or change to the vehicle or battery charger which alters the weight distribution of the vehicle, its stability, increases the speed, or alters the output of the battery charger beyond the factory specifications can cause personal injury and will void this warranty. Do not make any such modification or any other alteration, which would adversely affect the safety of the vehicle. Adding a folding rear seat to the car is the only exception that EVOLUTIONELECTRIC VEHICLES agreed cover under this warranty.

VOIDING OF WARRANTY: This, and any other warranty, shall be void if: (1) the vehicle or battery charger is abused or otherwise not used in its intended manner; (2) if it is in an accident or collision;(3) it shows indications that the speed setting was adjusted or modified allowing the vehicle of operate beyond EVOLUTIONELECTRIC VEHICLES specifications, including but not limited to alterations to the braking system, electrical system, steering or other operating systems of vehicle or shows indication that routine maintenance was not performed when and in the manner specified in the EVOLUTIONELECTRIC VEHICLES maintenance and service publications or owner's manual. This warranty shall be void with respect to any defect or damage caused by or as a result of or related to parts or accessories which are not manufactured or authorized by EVOLUTIONELECTRIC VEHICLES, or were not installed per EVOLUTIONELECTRIC VEHICLES instructions, or were covered by another manufacturer warranty, whether expired or not.



NO CHILDREN ARE ALLOWED TO PLAY WITH THE VEHICLE



DO NOT DRIVE THE VEHICLE WHILE UNDER THE INFLUENCE OF ALCOHOL OR DRUG



DO NOT LOAD THE VEHICLE WITH WEIGHT EXCEED MAXIMUM LOADING CAPACITY .



DO NOT DRIVE THE VEHICLE OVER 25MPH/H OVER SPEED DRIVING MAY CAUSE SEVERE INJURY

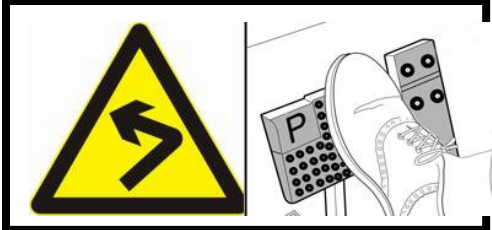

WHEN COMMIT SHARP LEFT TURN APPLY BRAKE TO LIMIT SPEED

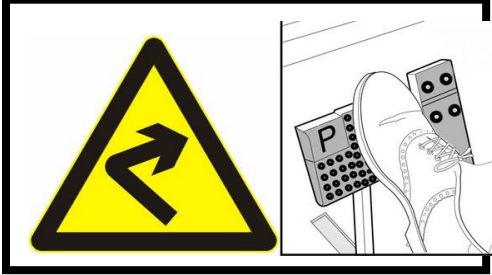

WHEN COMMIT SHARP RIGHT TURN APPLY BRAKE TO LIMIT SPEED



APPLY BRAKE TO LIMIT SPEED WHILE DRIVE ON STEEP HILL



DO NOT DRIVE VEHICLE ACROSS SLOPES IN EXCESS 25%



DO NOT USE THE CARGO BOX AS PEOPLE MOVER IN ANY KIND OF CIRCUMSTANCE



DO NOT LOAD THE CARGO BOX WITH FLAMMABLE ARTICLES SUCH AS GASLINE ALCOHOL ,ETC

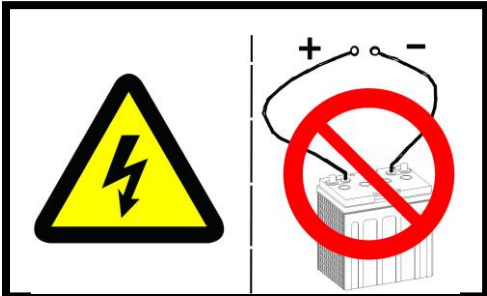

DO NOT SHORT CIRCUIT BATTERY TERMINALS AS IT WILL CAUSE SEVERE DAMAGES TO BATTERY . IT MAY CAUSE EXPLOSION .

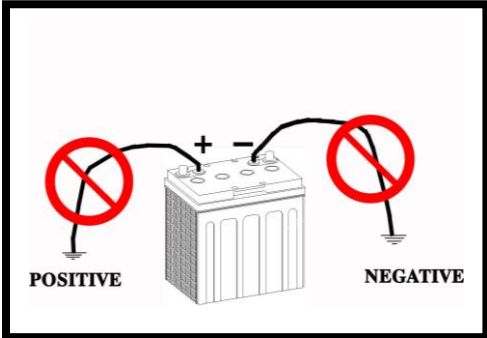

DO NOT SHORT GROUND ANY BATTERY TERMINAL TO EARTH ,IT WILL CAUSE SEVERE BATTERY DAMAGES .

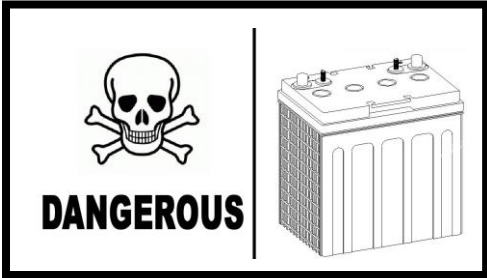

BATTERY POSTS, TERMINALS AND RELATED ACCESSORIES CONTAIN LEAD AND LEAD COMPOUNDS, CHEMICALS KNOWN CAUSING CANCER AND REPRODUCTIVE HARMS

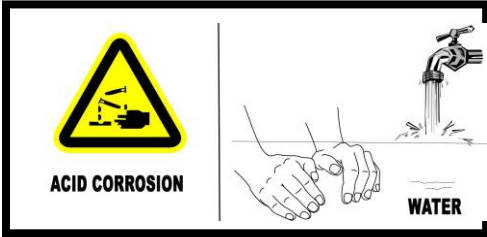

WASH HAND AFTER HANDLED BATTERY

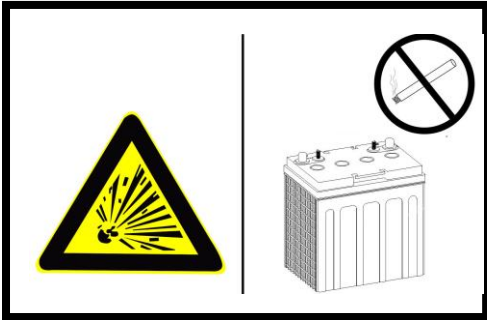

THE BATTERY WILL GENERATE HYDROGEN GAS IN CHARING PROCESS .KEEP SMOKE AND STATIC ELECTRICITY AWAY FROM BATTERY

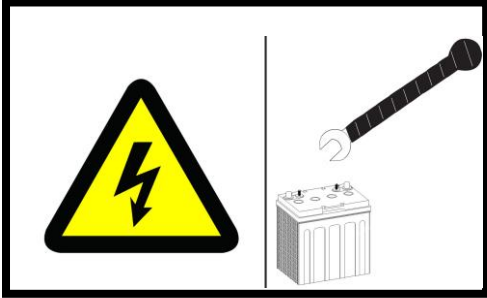

USE ISOLATED WRENCH TO OPERATE ON THE BATTERY IN CASE BATTERY SHORT CIRCUIT . SHORT CIRCUIT GENERATE BIG CURRENT WILL CAUSE INJURY

Grand Safety information

Owner’s manual contains safety regarding information , when followed decals come up ,owner should notice the safety statements.

CAUTION

Indicates the regarding situations , is very important .

WARNING

Indicates the regarding situations ,may cause minor injury or other lose

DANGEROUS

Indicates the regarding situations ,may cause death or serious injury.

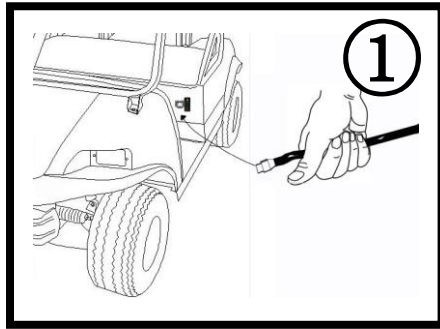

Before initiate using vehicle , the batteries should be fully charged . Charging hour should be more than 10 hours .

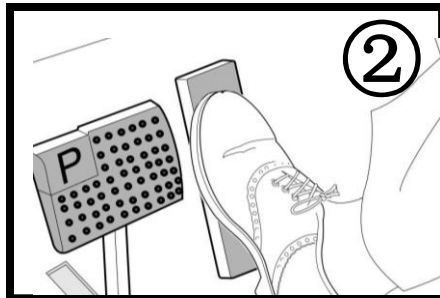

Check the accelerator pedal ,when stepped and released it should returns to its original position with full flexibility .

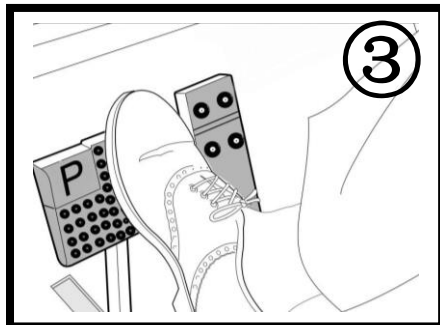

Check the brake pedal , when stepped it should be flexible and feels firm . And it returns to its original position with flexibility when released

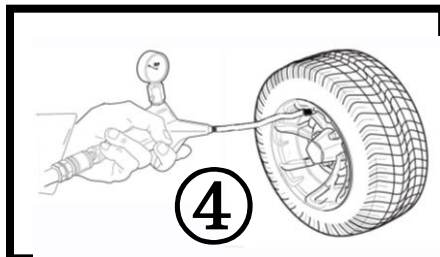

Check the tires' pressure ,it should be inflated until the internal pressure is around 20~23PSL(138kpa~159kpa)

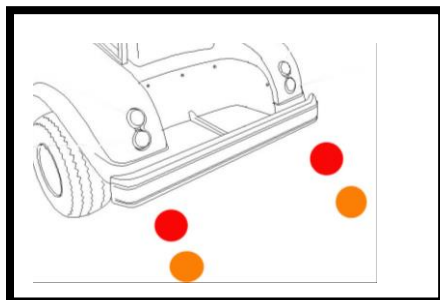

Check the signal lights , the brake lights and turning lights should be in proper working condition .

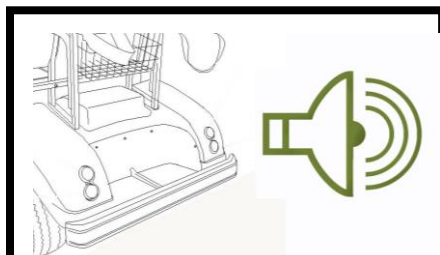

Check the reverse beeper ,when the direction selecting switch be set at “REV”, it should beep soundly

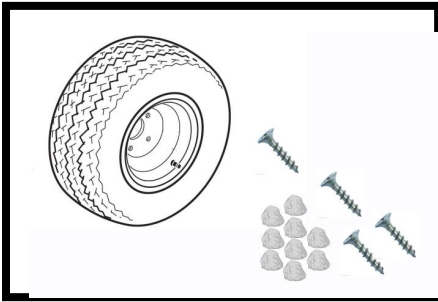

Check the tires' surface , remove any embedded objects you can find . Be sure no cracks or other damages to the tires ,defective tires may cause accident while driving .

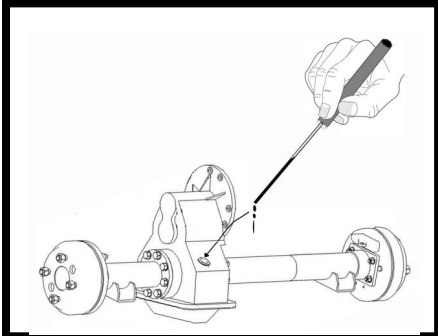

Check the lubricant capacity the rear axle contains , use a cleaned stick , stick it into the rear axle and it reach the bottom , pull it out check the depth is should be more than 13cm (1.3L).



Pull the steering wheel up and down ,check the tightness of steering wheel .Rotate the steering wheel right and left. Be sure no excessive free play and rattling sound .

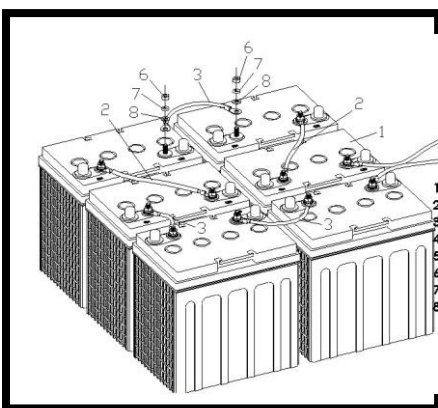

Check the tightness of the battery wiring , make sure all the nuts are solidly tight . Loose attached nuts on the battery will cause big spark while operating .

CAUTION

Pre-operations are extremely important , the owners of the vehicle should aware all the required operations need to be executed before initiate using the vehicle . The status of the vehicle is very important to the safety of the passengers on board .

BE SURE TO DO THE PRE-OPERATION JOB .

* Vehicle's serial number

Manufacturing year

201189678

Vehicle's serial number

Vehicles manufactured by EVOLUTION corporation, all have vehicle's serial number on the left side of the chassis frame. The front four numbers are the manufacturing year of the vehicle. The other five numbers are the vehicle's serial number given by EVOLUTION corporation. All the vehicles are documented. After the vehicles are sold out of the factory, EVOLUTION corporation will track the vehicles by using the vehicle's serial number as identity. Serial numbers are insurance warranty of EVOLUTION corporation. Customers should be aware of the importance of the vehicle's serial numbers **⚠ DON'T TEAR IT DOWN** while using the vehicles or in routine maintenance.



201189678

* Steering wheel decals



2



1



3

OPERATING INSTRUCTIONS

- Read owner's manual and dash-mounted safety warnings prior to driving.
- Study and understand controls.

TO OPERATE

- Turn wheels to desired direction and ensure path is clear.
- Turn key to ON position.
- While stopped, place Forward/Reverse switch in desired position:
F-Forward N-Neutral R-Reverse (Buzzer will sound)
- Park brake will release and vehicle will start moving when accelerator pedal is pressed.
- Slowly press accelerator pedal to increase speed.
- To stop, release accelerator pedal and press brake pedal.

BEFORE LEAVING

- Press park brake pedal until it locks and holds vehicle.
- Place Forward/Reverse switch in NEUTRAL position.
- Turn key OFF and remove key when not in use.

MOTOR BRAKING

- Electric motor braking provides speed regulation functions.
- For parked vehicle, beeping alarm indicates vehicle roll away.
- In operation, beeping alarm indicates reduction in motor braking.
- Apply brakes to further reduce vehicle speed as required.
- System is activated only when tow switch is in the RUN position.
- When towing this vehicle, tow switch must be in the TOW position.

CCI 102518001

* Charger's decals

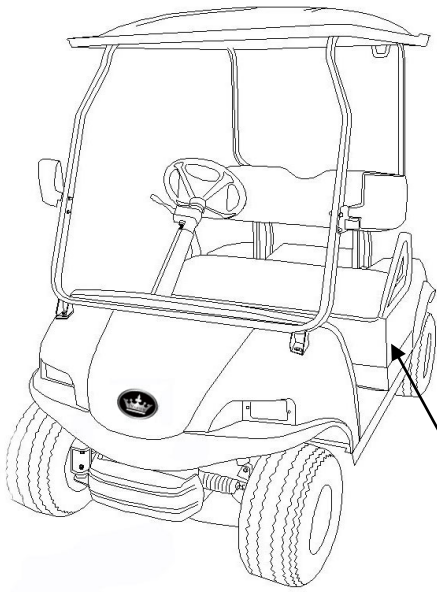



②



①

③



MODEL: 29700E05AMB000B2 29700 

INPUT: 100-240Vac, <8A 

50/60Hz, 1PH

OUTPUT: 48Vdc, 13.5 A, 650W

BATTERY: 22201 24 CELL 150-435Ah

INDUSTRIAL BATTERY CHARGER 0817W2345

①. Charger

②. Charger's indicating decal

③. Charger's specification decal

IMPORTANT DECALS

* Charger's serial number

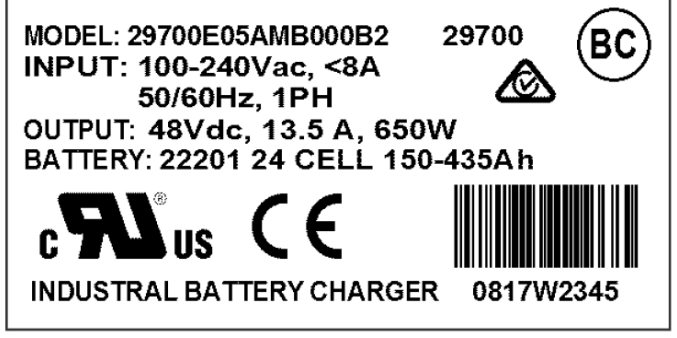
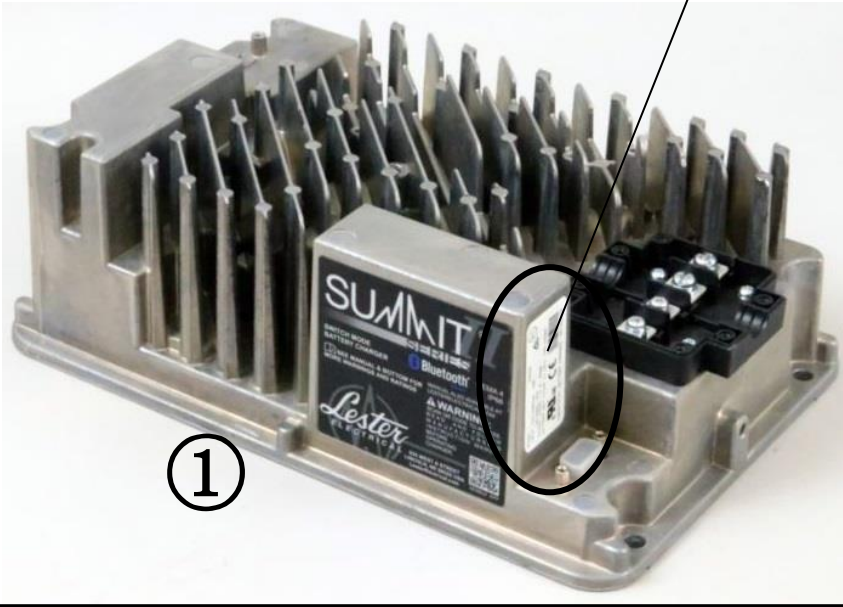

①. Charger's manufacturing year ②. Charger's serial number

* Speed limit decal

CAUTION

THE VEHICLE'S MAXIMUM SPEED IS 25 MILES PER HOUR AND IT MAY BE A HAZARD ON THE ROADWAYS IF IT IMPEDES TRAFFIC ,FOR WHICH ,THE DRIVERMAY BE CITED

Vehicle speed limit label .

* Reflexion decals (optional)



REAR REFLEXION DECAL

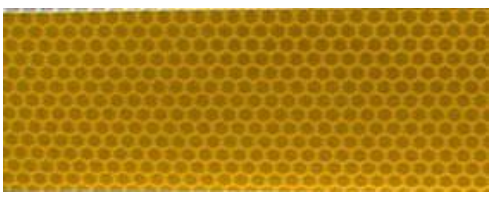

SIDE REFLEXION DECAL

* Motor decal

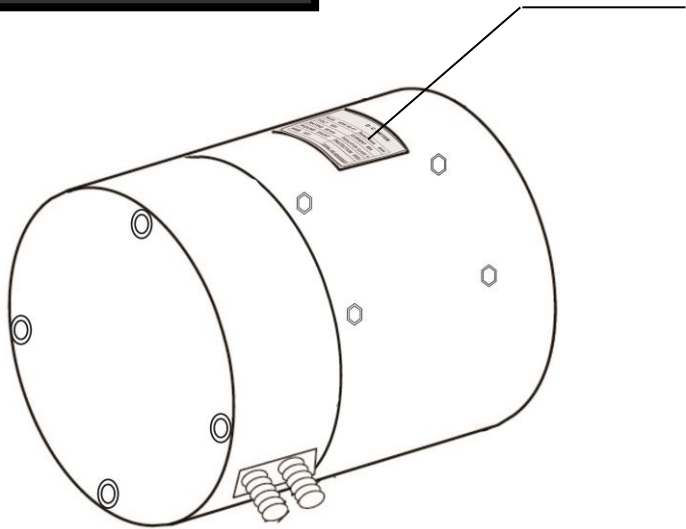

AC- MOTOR			
MODEL	XQY-4-L	POWER	4KW
VOLTS	31V/AC	SPEED	3000r/min
CURRENT	105A	FREQ.	102Hz
INSULATION	H	DUTY	S2-60min
NO.	170402827	DATE	20170927

Motor specification label & serial number label .

* Controller

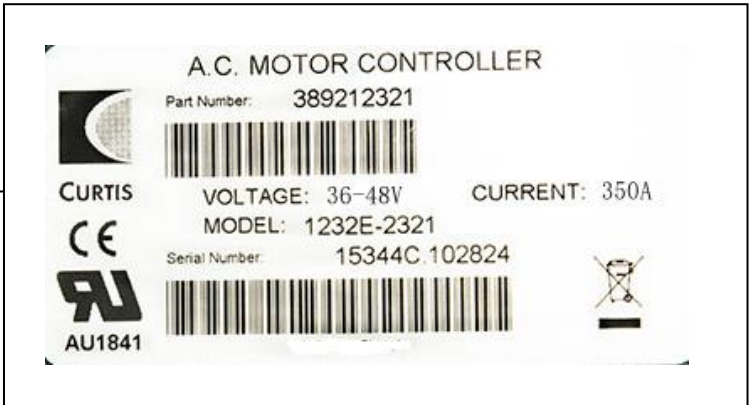

- .Controller Type label
- .Controller specification label
- .Controller serial number label

* DC converter decals

①

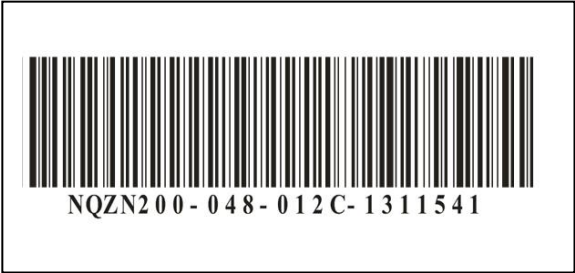

②



③

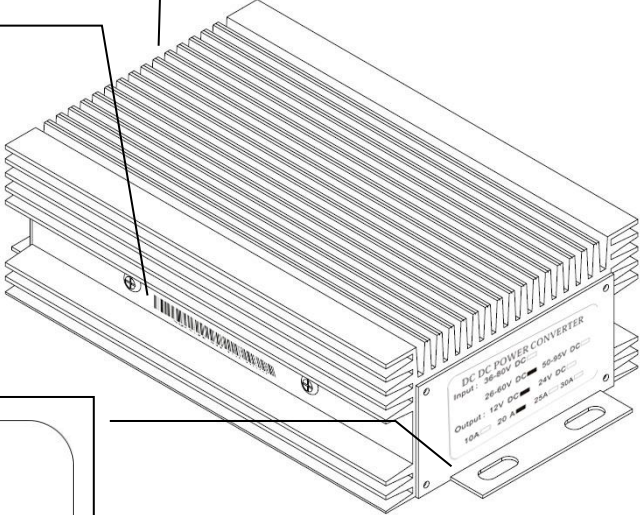
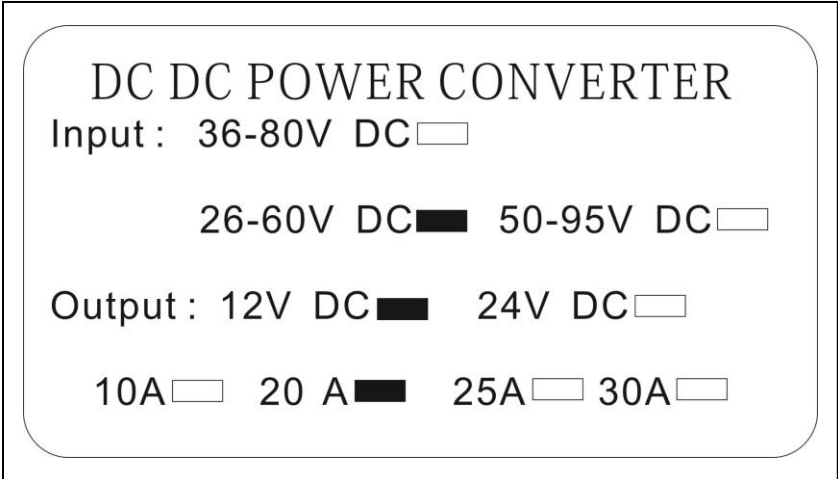

- ①. Serial number
- ②. Cable indication label
- ③. Specification label

* Brake and accelerator

※MECHANICAL

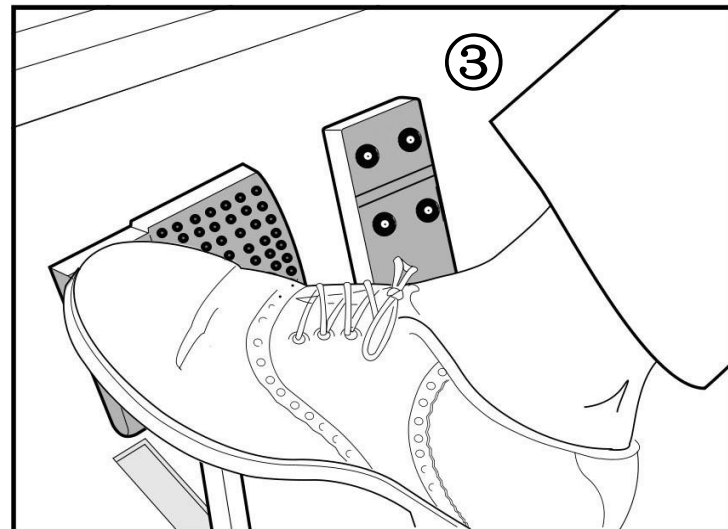
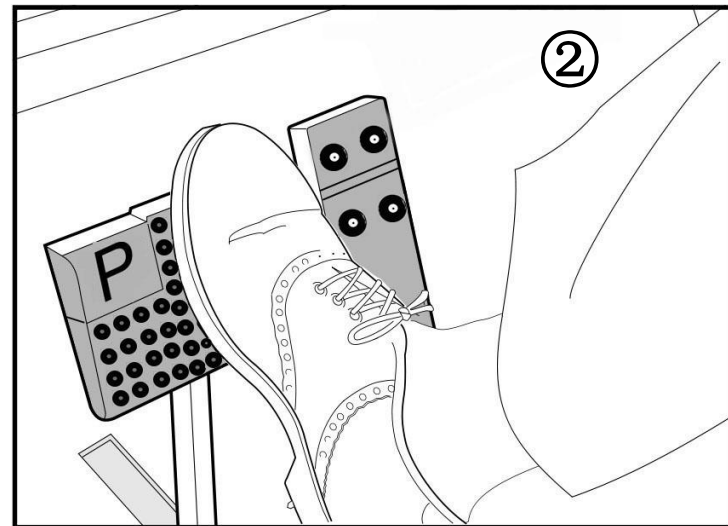
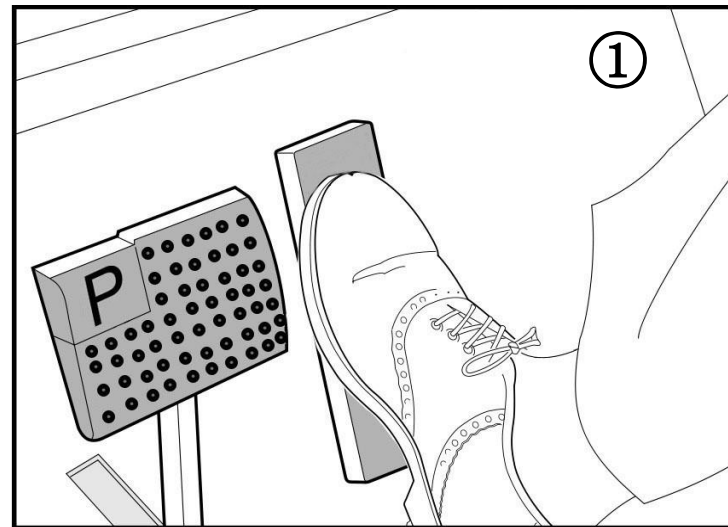

① Use the accelerator pedal to control the vehicle's speed . ② Use the brake pedal to decrease velocity . ③ use parking pedal to keep car in static .

※HYDRAULIC

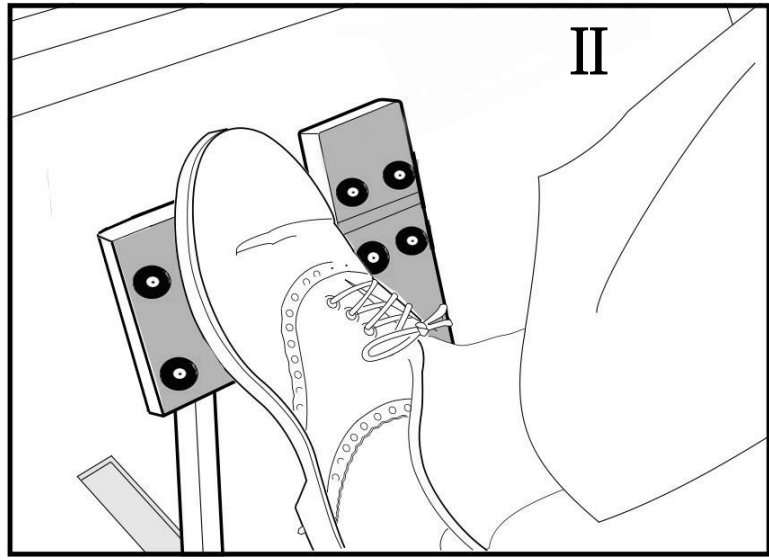
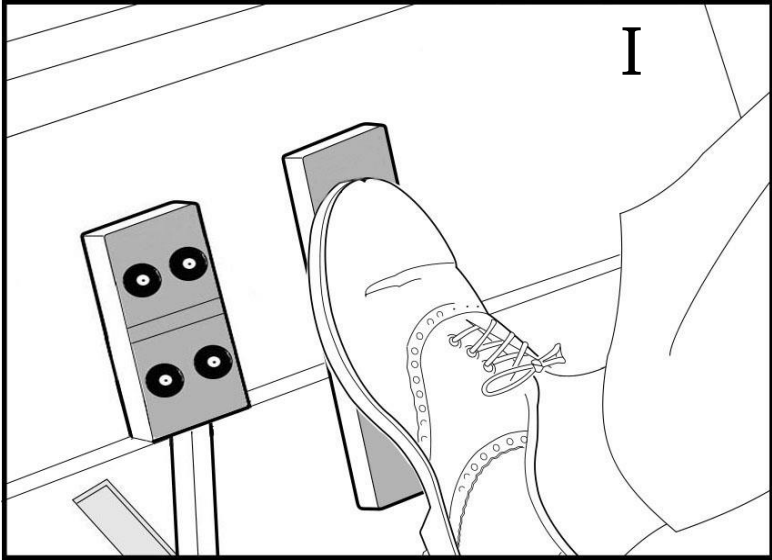
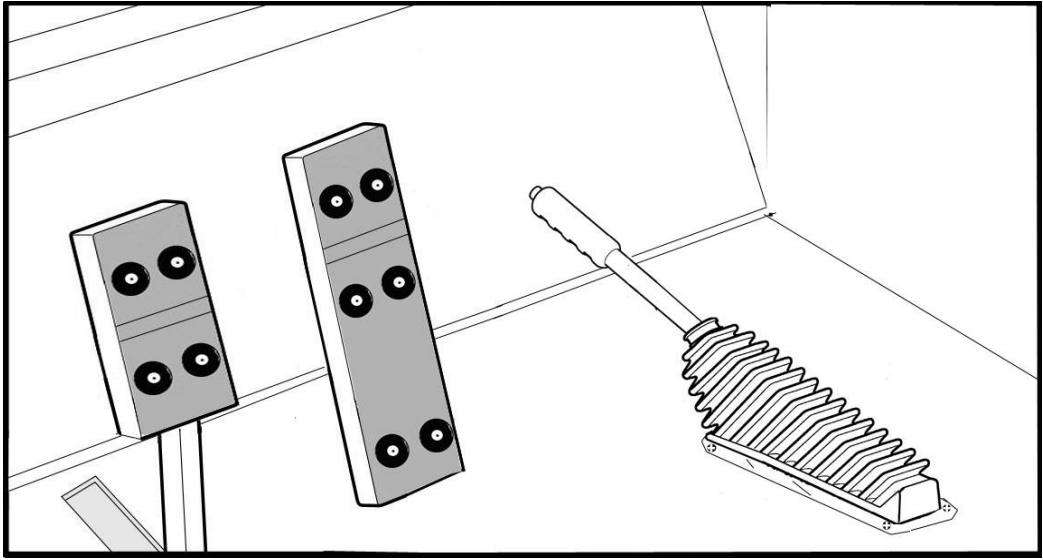

I .Accelerator pedal
II . Brake pedal
III.Hand brake
(Functional as parking pedal).

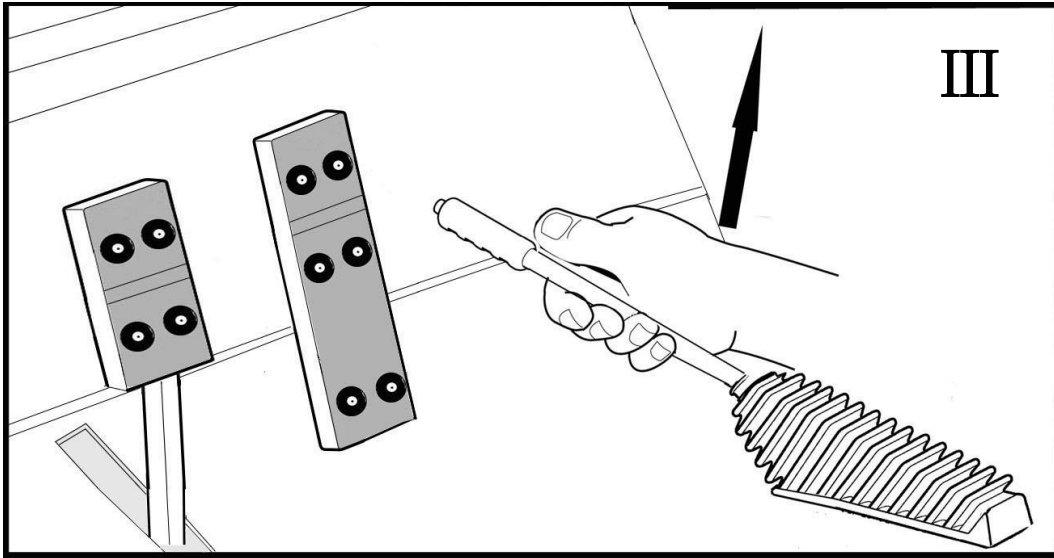

* Key switch and indicators

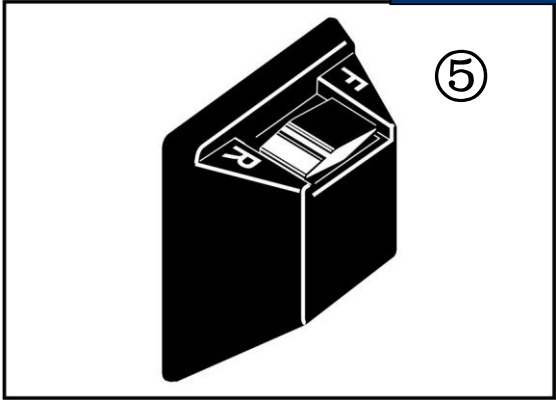
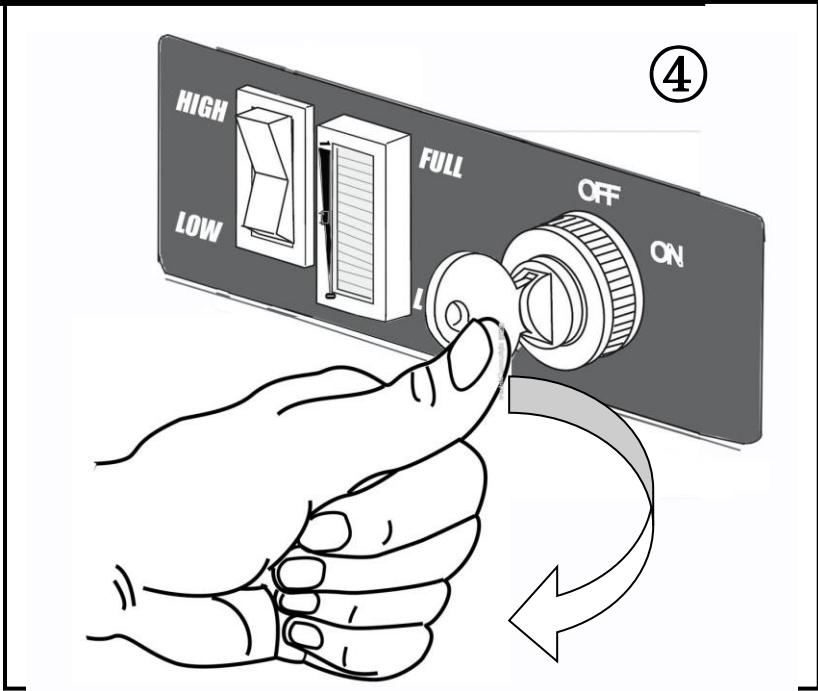

④ Use key switch to turn on the main power. ⑤ Use direction selecting switch to change the vehicle's moving direction.

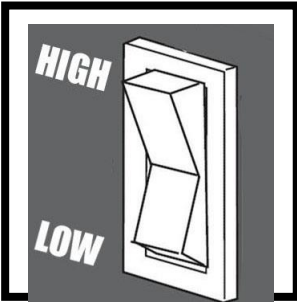
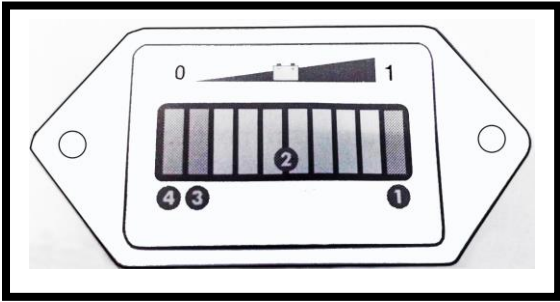

HIGH: Maximum speed
LOW: Half of Maximum speed

- ① only when the battery is properly charged is the right-most LED lit.
- ② As the battery's state-of-charge decreases successive LEDs light up. only one on at a time.
- ③ The 2nd-from-left LED flashes ,indicating “energy reserve”(70% depth of the discharge).
- ④ The 2 left-most LEDs alternately flash, indicating “empty”(80%depth of discharge).

* Dashboard functions

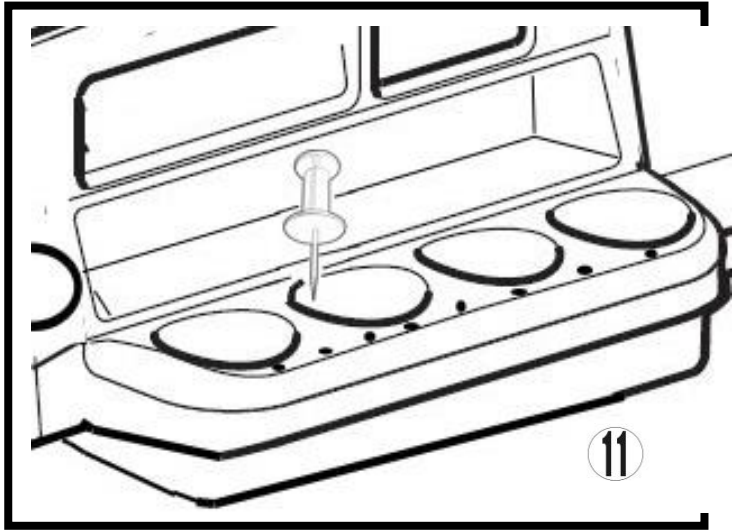
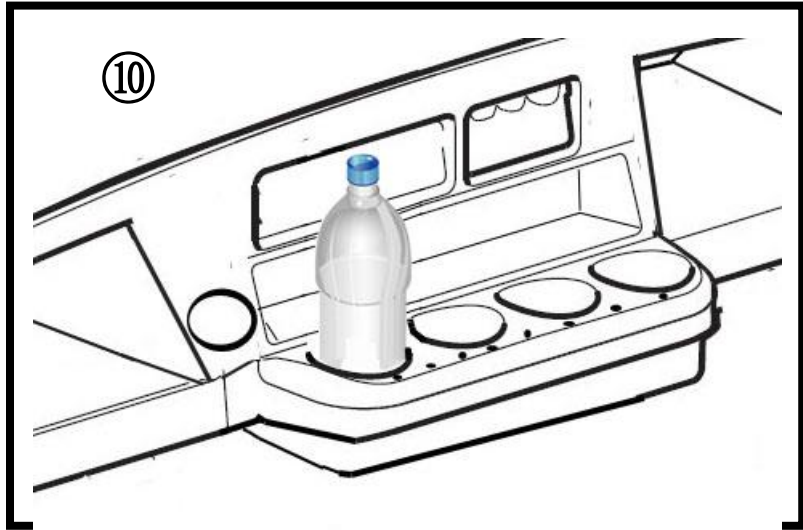
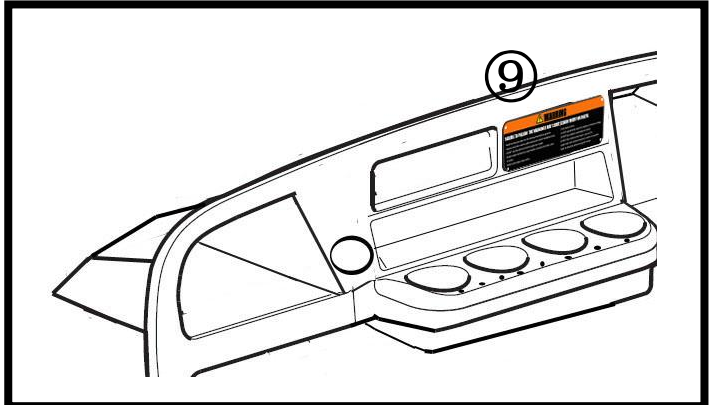
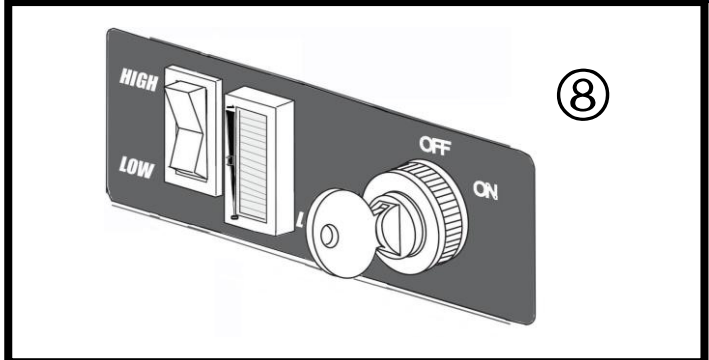
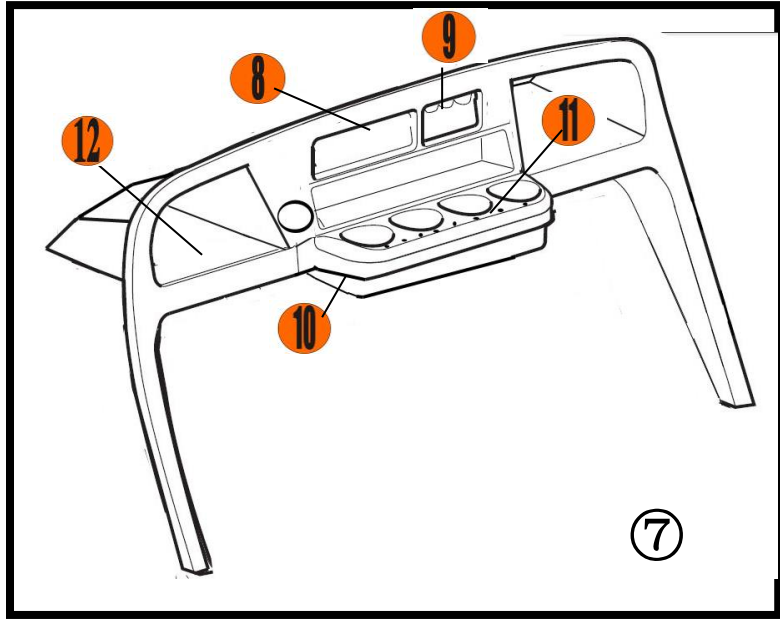

(7)Dashboard (8) Controls and indicators panel (9)Warning Plate (10)Bottle holder (11) Tee holder (12)Glove box

※NOTES

Golf car dashboard is designed according the usages ,that the vehicles are applied in golf course field . owner should get familiar with the functions that the vehicle have .

* Speedometer

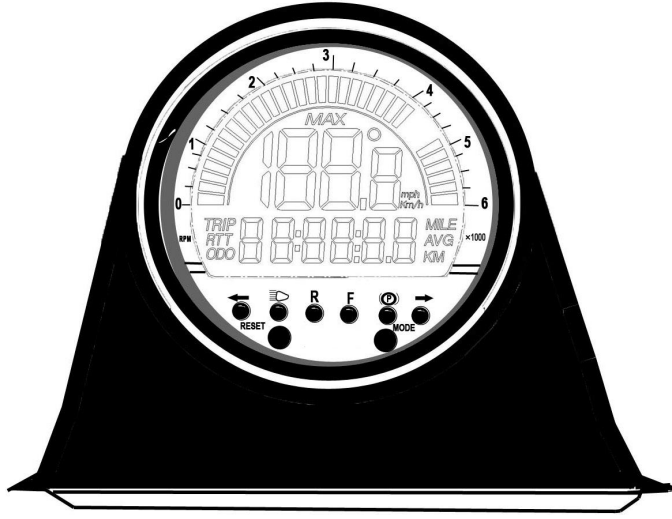

For EVOLUTION vehicles that installed with speedometer .EVOLUTION Speedometer is a multifunction indicating device .It can indicates vehicle velocity ,running time etc .The vehicle operation direction also have indicating LEDs on the speedometer ,when conduct brake on the vehicle or been parked the speedometer also have a indicating LED indicates the operation .

For all the lights vehicle have ,all the lights status will indicate on speedometer. When you turn the headlights on the headlight LED will be turned on as well . when you turn the turning lights on the turning lights indicating LED will be turned on and flash as well .

The speedometer also will show motor's rotation speed on speedometer ,when steering the vehicle , as the accelerator changes the motor's rotation speed changes as well. Current motor rotation speed will shows on the top of speedometer(number times 1000,eg . when the speedometer shows 3 then the motor's rotation speed is 3000RMP)

operation instructions

I .To change the running indicating modes you can press “MODE” button to change the running modes between “RT” and “RTT”

II . To change the speed unit of the speedometer ,you can press “MODE” button set the running indicating mode to “RTT” ,then press “RESET” button for 4 seconds .the speed unit will changes between km/h and mph

※NOTES

For more speedometer functions please contact dealers or EVOLUTION company .

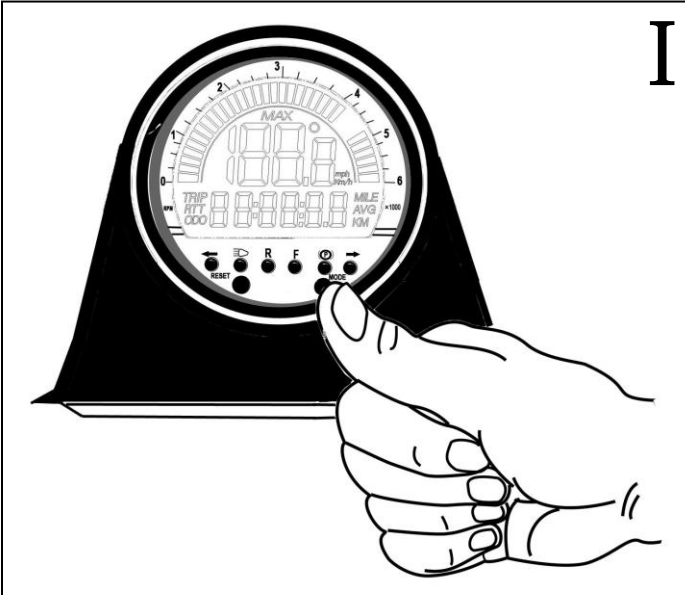

I

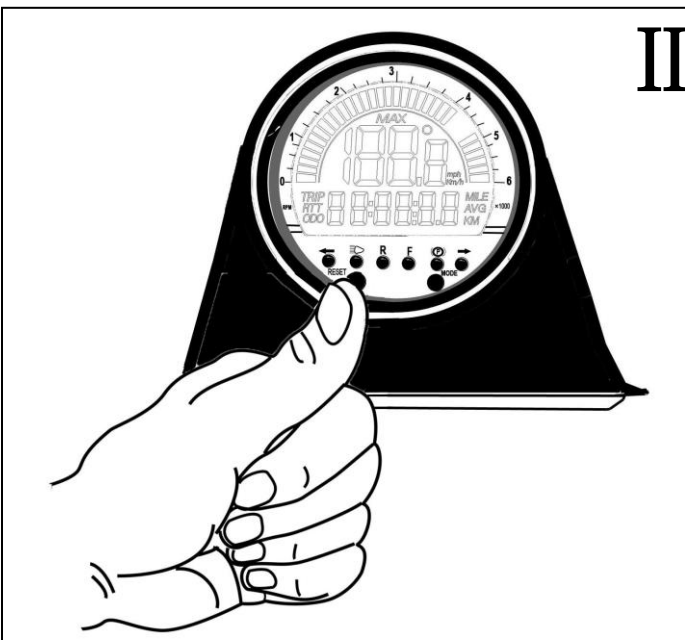

II

* Speedometer functions

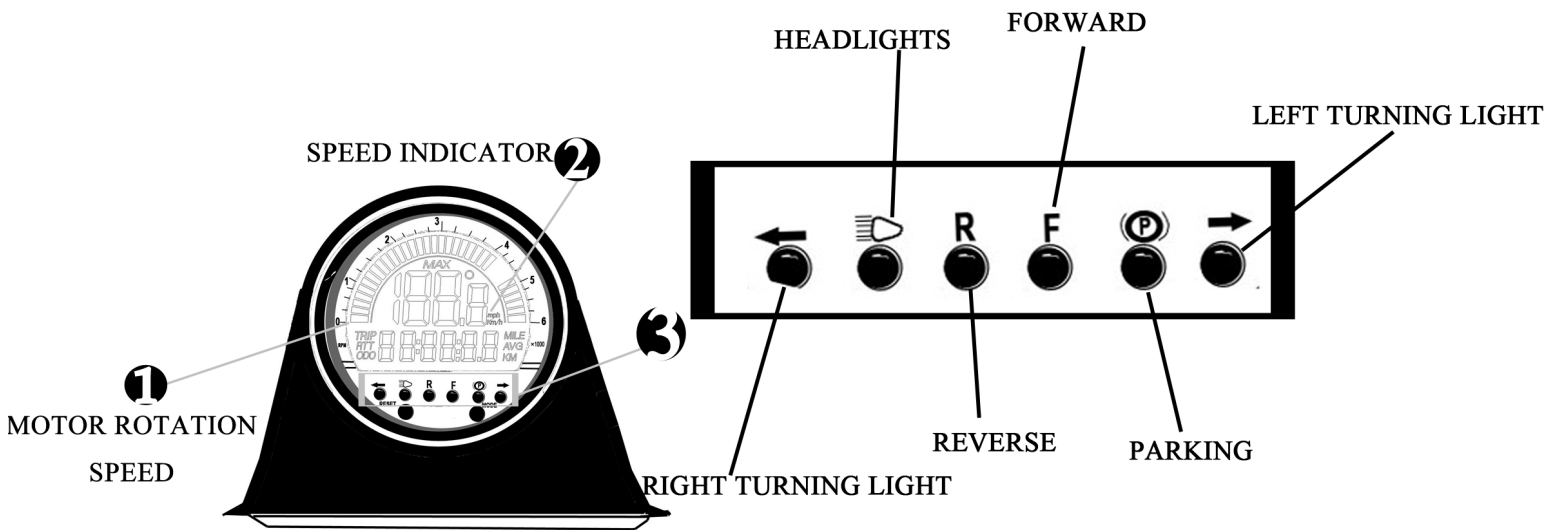

- 1.Speed display by digital (are precise as to 0.1 Km/H, anti-shake)
- 2.The bar code shows the RPM / Speed
- 3.Electric consumption display (6 shelves, have two kinds of alarm)
- 4.Single course distance (TRIP)
- 5.Total mileage (ODO)
- 6.The electric car operates once riding time (RT)
- 7.The electric car operates total time (RTT)
- 8.Kilometer / Mileage switching
9. The inside parameter adjusting
10. Turn left, turn right, high light, parks, trouble, low light LED indicator lamp
11. Light green back light / always lighting

NOTICE

All the speedometer functions are not all integrated inside of the speedometer ,All the functions listed are for customers to choose .

For EVOLUTION vehicles that configured with speedometer ,all the speedometer If other functions needed except the standard configured functions .Customers have to place the order in advance ,and list the functions needed specifically.

* How to use the function adjusting wire?

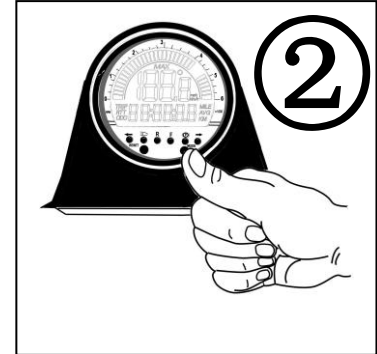
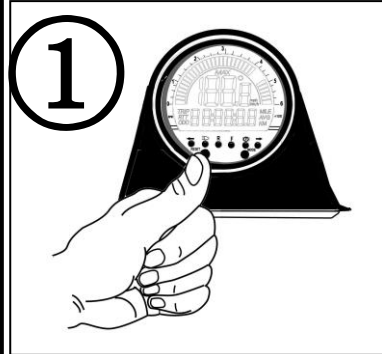
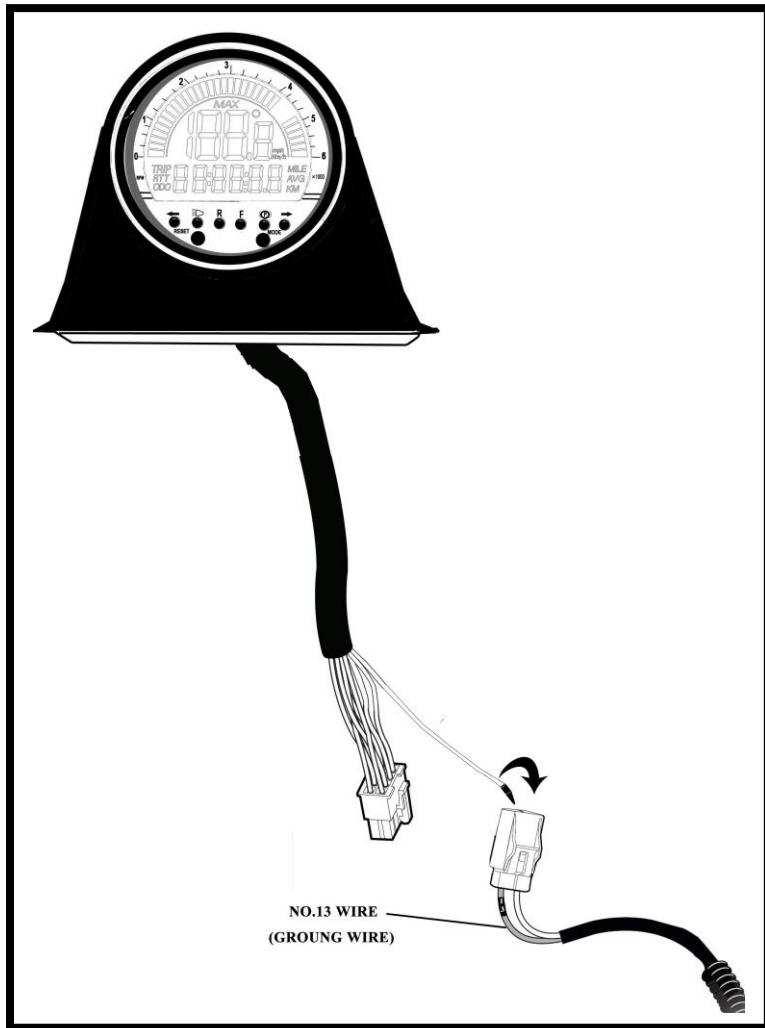

Keep vehicle's power on ,keep the speedometer plug connected on the wire harness .

Use the function adjusting wire to touch the number 13th wire (Ground wire) for 5 second , then brake up the speedometer will enter into the configuration screen .

After enter into the function adjusting mode ,use the "RESET" button to change the value ,use the "MODE" button to select the number digit that you want to change the value . Keep pressing the "MODE" button until the screen jump into the next function adjusting

1. Set up the equivalent tire circle long (Show for " P0 ")

equivalent tire circle long = (the diameter mm * 3.14 of wheel) / (4 * The axle of the electrical motor and transmission among the wheels)

1 inch (British) = 25.4 mm 1 inch = 33.33 mm

- The figure is " 4 " Number of The electrical motor pulse touches number each circle (Inside this Instrument acquiescence 4) , If your electrical motor pulse touches number each circle is not " 4 " , Then please take the place of the real figure into in the formula directly " 4 " .
- The equivalent tire circle long value of the maximum to be 5000, in order to improve the precision it can accept double digit after a dot.

2 Display mode: 123456.78

Set up total mileage value (Show for " P1 "),Total mileage value allows 6 digital display, display mode: 123456 ,When the total mileage is set up, only show the metric unit. .

3. Set up the total running time of electric car: (show for " P2 ")

The maximum of total running time is 9999.0 hours, while setting up, show the unit is only hour, and is precise as to the last 1 of

4. Set up the display mode of running time: (show for " P8 ")

This instrument offer two running time display mode, show for(take 150 minutes as an example) :

dd: d shows as 2:30

dd..d shows as 2.5

* Lights and horn control

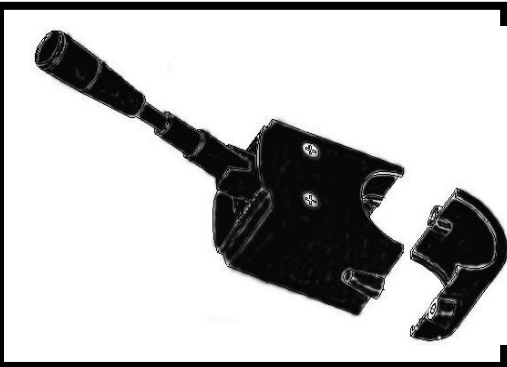

Switch assembly

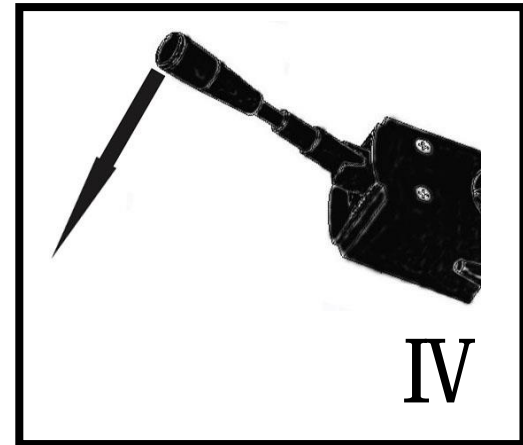
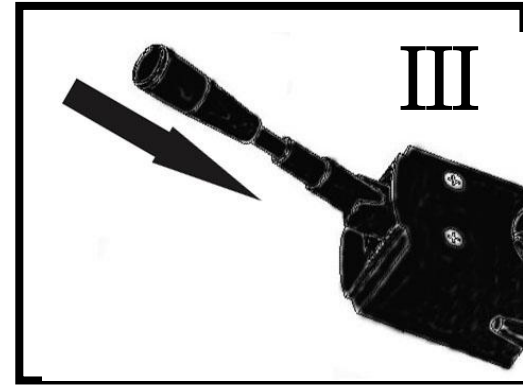
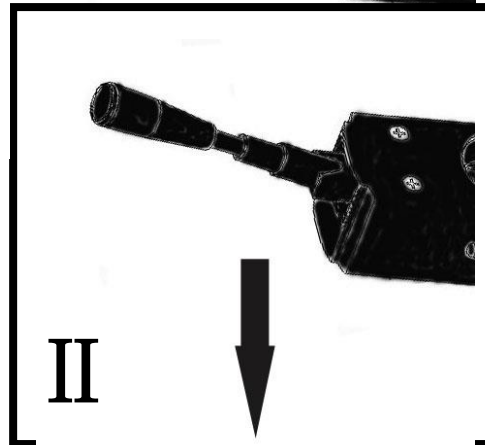
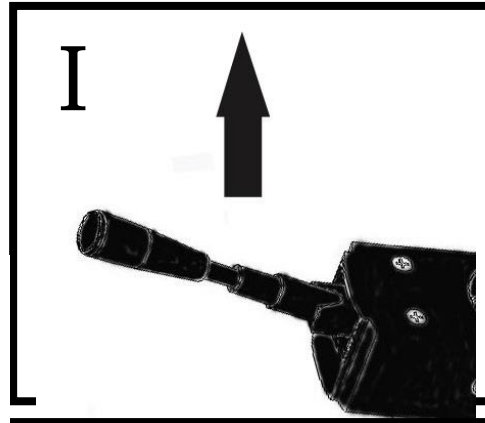

I . Turn on the right turning lights II . Turn on the left turning lights

III. Horn button IV. Turn on the headlights

Grand information of operation

Always use the vehicle in a responsible manner and maintain the vehicle in safe operating condition.

Always read and observe all warnings and operation instruction labels affixed to the vehicle.

Always follow all safety rules established in the area where the vehicle is being operated.

Always reduce speed to compensate for poor terrain or conditions.

Always apply service brake to control speed on steep grades.

Always maintain adequate distance between vehicles.

Always reduce speed in wet areas.

Always use extreme caution when approaching sharp or blind turns.

Always use extreme caution when driving over loose terrain.

Always use extreme caution in areas where pedestrians are present.

* Lester battery charger

1. Charger Introduction

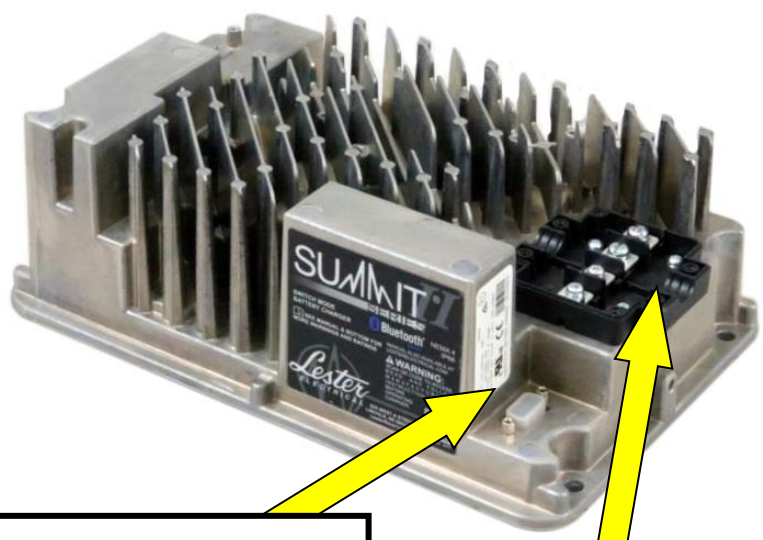

IEC INLET for AC input

External port for external charge LED indicating light.

DC output Cordset



Charger LED Indicators

Green light : CHARGER COMPLETE

Yellow light :CHARGE STATUS

Red light :FAULT STATUS

Blue light :AC PRESENT

2. Charger LED Status

The functionality of the LEDs is outlined below and in the following table.

1. **AC PRESENT (Blue)** - Indicates charger is connected to a live AC inlet.
2. **FAULT (Red)** - Indicates when a charger or battery fault has occurred (see section 12.2 for more information).
3. **CHARGE STATUS (Yellow)** - Indicates charge cycle status.
4. **CHARGE COMPLETE (Green)** - Indicates when a charge cycle completes successfully, when an extended Balance/Equalize charge cycle phase is active, or when a post-charge phase is active.

FAULT (Red) LED	CHARGE STATUS (Yellow) LED	CHARGE COMPLETE (Green) LED	DESCRIPTION
Solid On	Solid On	Solid On	LED check for a few seconds during charger initialization
	Slow Blink	Off	Bulk/Start charge cycle phase (constant power or constant current).
	Fast Blink	Off	Absorption/Plateau charge cycle phase (constant voltage). Greater than 80% charged.
	Solid On	Off	Finish charge cycle phase (constant current). Not all charge profiles include a Finish phase.
	Off	Fast Blink	Balance/Equalize phase. An extended charge cycle is occurring because a trigger condition has been met (cycle count, etc). Not all charge profiles include a Balance/Equalize phase.
	Off	Solid On	Charge cycle complete.
	Off	Slow Blink	Charge cycle complete. Post Charge phase (constant voltage float, etc). Not all charge profiles include a Post Charge phase.
Slow Blink	Slow Blink	Slow Blink	Charger Bluetooth connected to a smart phone or device, LEDs blink at the same time

3. Charger LED Faults

The charger will indicate when a fault occurs by using different patterns of the Fault (Red), Charge Status (Yellow), and Charge Complete (Green) LEDs as explained in the table below. Using the ChargerConnect App, check the diagnostic tab to get a description of the charger fault.

	FAULT (Red) LED	CHARGE STATUS (Yellow) LED	CHARGE COMPLETE (Green) LED	DESCRIPTION
Charger	Slow Blink	Solid On	Solid On	DC DISCONNECT – DC disconnect detected via the third-pin, but DC (battery) voltage is still present at the charger output. (Third-pin DC disconnect sensing is an optional feature available with supported DC plug/receptacle systems to minimize charger output inhibit time when a DC disconnect occurs during charging.)
	Slow Blink	Off	Solid On	OVER TEMP – Maximum temperature was met. Charge cycle was halted and will restart when the temperature decreases.
	Slow Blink	Fast Blink	Slow Blink	LOW TEMP – Temperature is too low to start a charge cycle (< -25°C). Charging will start when temperature increases.
	Slow Blink	Solid On	Off	LOW DC – DC (battery) voltage is too low to start charging (< 10V).
	Slow Blink	Off	Off	NO AC – AC power was lost during charging. Charge cycle was halted and will restart when AC power returns.
	Slow Blink	Solid On	Slow Blink	HARDWARE FAULT – Contact Lester Electrical.
	Slow Blink	Slow Blink	Off	HARDWARE FAULT – Contact Lester Electrical.
	Slow Blink	Slow Blink	Slow Blink	COMM FAULT – LEDs blink one at a time in a rotating pattern. Contact Lester Electrical. Unit is still able to charge.
	Slow Blink	Slow Blink	Solid On	HARDWARE FAULT – Contact Lester Electrical.
	Fast Blink	N/A	N/A	HARDWARE FAULT – Contact Lester Electrical. Unit is still able to charge.
Battery	Solid On	Off	Off	PHASE – A fault condition (most commonly maximum time) was met during a particular charge cycle phase (start/bulk, plateau/absorption, finish, etc).
	Solid On	Off	Slow Blink	MAX VOLTAGE – Maximum voltage was met.
	Solid On	Off	Solid On	MIN VOLTAGE – Minimum voltage was met after a specified time from the start of the charge cycle.
	Solid On	Slow Blink	Off	MAX AMP-HOURS – Maximum amp-hours for the overall charge cycle was met.
	Solid On	Slow Blink	Slow Blink	MAX TIME – Maximum time for the overall charge cycle was met.

N/A = Not applicable, LED state does not matter

4. Charger bluetooth wireless

The charger features Bluetooth wireless communication, which can be accessed using an Apple® or Android™ smart phone, tablet, or similar device. Download the ChargerConnect app for your device by scanning the QR code on the charger or visiting the App Store® or the Google Play™ store and searching for "ChargerConnect".

The charger communication electronics are DC powered, so the charger must be connected to a valid battery pack in order to communicate with it via Bluetooth. If the charger is connected to a valid battery pack, open the ChargerConnect app and select the charger from the list of available units the app is able to communicate with. The charger serial number is the identifier of the unit, unless the "Charger ID" has been previously changed via the app. While connected, the Red, Yellow, and Green LEDs on the charger will slowly blink at the same time until the Bluetooth communication is disconnected from the charger.

DANGEROUS

ONLY PROFESSIONAL PERSON ARE ALLOWED TO CONDUCT THE ADJUSTING OR REPAIRS ON CHARGER . ANYONE WHO HAS NO EXPERIENCE ON ELECTRONIC COMPONENTS MAINTENANCE ARE NOT ALLOWED TO OPERATE ON THE CHARGER . UNREQUIED OPERATIONS ON THE CHARGER MAY CAUSE ELECTRIC SHOCK , MAY LEAD TO DEATH .

WARNING

DO NOT OPEN UP THE CHARGER . ANY ATTEMPTIONS TRY TO REPAIR DEFECT CHARGER SHOULD UNDER THE GUIDANCE OF DEALER OR MANUFACTURER'S TECHNICIAN .

CAUTION

 USE THE CHARGER ONLY WITH AN ALGORITHM SELECTED THAT IS APPROPRIATE TO THE SPECIFIC BATTERY TYPE .OTHER USEAGE MAY CAUSE PERSONAL INJURY AND DAMAGE..LEAD ACID BATTERIES MAY GENERATE EXPLOSIVE HYDROGEN GAS DURING NORMAL OPERATION.KEEP SPARKS FLAMES, AND SMOKING MATERIALS AWAY BATTERIES.

 PROVIDE ADEQUATE VENTLIATION DURING CHARGING. NEVER CHARGE A FROZEN BATTERY .BATTERIES' CAPS SHOULD BE REMOVED WHILE CHARGING .

 RISK OF THE ELECTRIC SHOCK. CONNECT CHARGER POWER CORD TO AN OUTLET THAT HAS BEEN PROPERLY ISTALLED AND GROUNDED IN ACCORDANCE WITH ALL LOCAL CODES AND ORDINANCES.A GROUND OUTLET IS REQUIRED TO REDUCE RISKOF THE ELECTRIC SHOCK.. DO NOT USE GROUND ADAPTERS OR MODIFY PLUG. DO NOT TOUCH UNINSULATED PORTION OF THE OUTPUT CONNECTOR OR UNINSULATED BATTERY TERIMALS

 CHILDREN SHOULD BE SUPERVISED TO ENSURE THAT THEY DO NOT PLAY WITH THE APPLIANCE

NOTES

EVOLUTION on-board charger is specially designed for EVOLUTION vehicles . The charger's working voltage range from100V~240V ,working frequency range from 50HZ ~60HZ . Customers from all over the world can use EVOLUTIONon-board without any changes .

EVOLUTIONon-board charger can be operated in the temperature -30°C~+50°C(-22°F~122°F) ,which allows EVOLUTION on-board charger to be used in most circumstances .

* EVOLUTION vehicle batteries connection

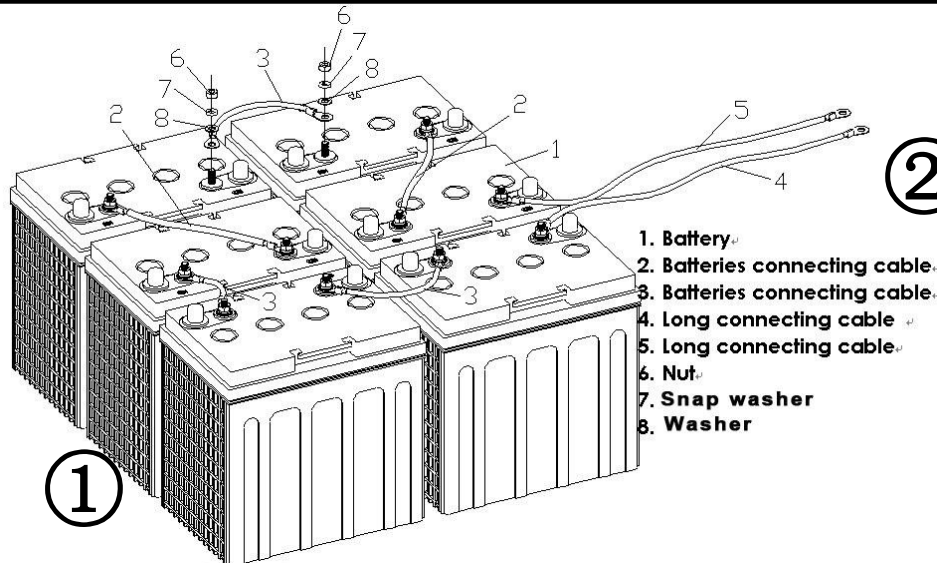

Batteries loaded on EVOLUTION vehicles ,according to different configurations ,customers who purchase EVOLUTION vehicles can choose different batteries (figure 2 are the batteries available).The batteries are connected in series circuit pattern :

System	Battery QTY(PCS)	Single battery voltage(V)
36V	6	6
48V	6	8
48V	8	6

Batteries EVOLUTION vehicles can

Trojan flooded	Trojan T875
Trojan T105 flooded	Us 2000 flooded
Discover 80-150AH AGM	US2200 flooded
Discover AGM	Us 250hc flooded
US battery flooded	6TB-170AGM
Trojan 30XHS	Generic 140-200Ah AGM
Trojan J305	Generic 200-250 Ah AGM
Generic 200-255 Ah flooded	Generic 250-335 Ah AGM
Trojan 1275	Generic 140-200Ah flooded
Trojan T605	Generic 250-335Ah flooded
12TB-115AGM	Generic 400Ah flooded

- i.the exterior of the battery ,the connection wires and bolts should be kept clean and dry .If there is electrolyte outside the battery, please clean with dry cotton yarn firstly,then wash with water and finally wipe up .(while cleaning ,do not allow any cleaning solution ,or water to get inside the battery, to avoid leakage and increasing self-discharge)
- ii. The connection of the battery should always be kept in good condition .please check if any battery cable terminal or nut has become loose periodically in order to prevent any sparkle or damage to terminals .
- iii.Do not place any object on the battery and do not connect the positive pole to the negative pole .this may cause a short circuit ,damage to the battery or injury to your body .
- iv.The battery should be recharged fully when not in use . any delay on the re-charging will cause negative effect on the battery .
- vThe evaporation and electrolyzing of the water will cause the density of electrolyte of the battery increased and the liquid surface decrease ,especially in hot water.therefore,check the distilled water or the attenuated sulfuric acid for lead-acid battery with density of 1.40 to adjust the electrolyte to meet the density of the 1.28,the surface should be flat with highest level then continue to charge0.5-1 hour in order to make the internal uniform .
- vi.Any impurities are not allowed to enter the battery. Keep the apparatus clean for adding water to avoid the impurities to be fallen into the battery.
- vii.When driving , the driver shall be always be aware of the drop level the battery power from the batteries' capacity indicator .the driver shall estimate the distance needed to be taken,and recharge the battery at a proper time in case that the car can not get back to the recharging station in time for recharging .
- viii. If the golf car is going to be kept unused for a period of time ,the battery shall be fully charged before put away. After that ,the battery fully recharged every month ,until the charger turn off automatically
- ix.During charging ,the car shall be parked in a well-ventilated area with the fill caps open. Keep car far away from any frame and sparks and avoid any explosion or fire that could cause physical injury or damage to the property.
- x.once charged the cap should be kept tightly covered.

* Electric vehicle battery concept

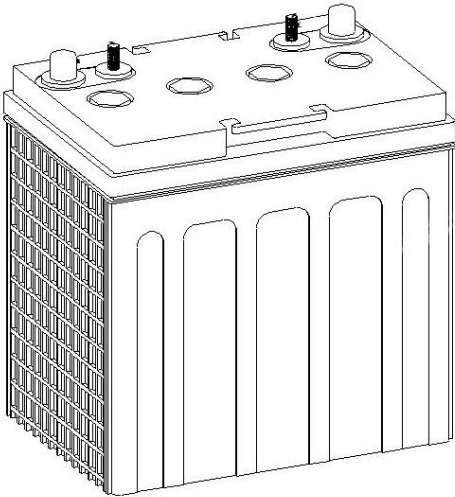

Electric vehicles use batteries as power supply to keep the vehicle on run, the capacity of the battery will be critical to the running range of the vehicle .

The batteries applied on the EVOLUTION vehicle can be : 6V /8V/12V , according to different vehicle system , owners of the vehicle can choose different batteries as options ,Batteries selecting need to have certain things considered as followed :

- ①. The total voltage of the batteries need to match the vehicle system voltage .
- ②. The total current of the batteries , need to be kept under the maximum durable current of the system .
- ③. The batteries be connected in series circuit pattern , be sure only the same type of batteries that from same manufacturer are allowed to be connected together .
- ④. The batteries with in same phases of usage are all allowed to be connected together ,different phases of the batteries be connected together will severely affect the life time of the batteries unit .

* Batteries' capacity and vehicle running

EVOLUTION golf cart series , hunting cart series ,have 8 battery installing positions available . For attaching different running range of the vehicle , owners can choose different batteries as configurations of the vehicle. The batteries selection can use following concepts as reference .

I. Lower voltage batteries always have bigger capacities , For attaching further running range , owners can choose smaller voltage (bigger battery capacity)as option . The calculations are as below .

36V / 48V system : ① 36V system: i. use 6 unit of 6V batteries .
ii. use 3 unit of 12V batteries.

VEHICLE RUNING RANGE COMPARISON : i>ii

② 48V system : i.use 6 unit of 8V batteries.
ii.use 8 unit of 6V batteries.
iii.use 4 unit of 12V batteries.

* Different configurations of battery

WARNING

THE FOLLOWING OPERATIONS MAY CAUSE NO REPAIRABLE DAMAGES TO VEHICLE SYSTEM COMPONENT ,PLEASE OPERATE UNDER THE INSTRUCTION OF SPECIALIST AND WITH CAUTIONS .

I .Over voltage

To boost the vehicle in order to have more powerful performance, one extra battery can be added to the battery pack in series connection pattern .

Original battery pack system :48V

Voltage allowance no exceed the limits : 56V

Battery can be added to the system :one piece 6V or 8V

II .Over current

To boost the vehicle in order to have more powerful performance, one extra battery pack can be added to the battery pack in parallel pattern .

Original battery pack system :48V

Voltage allowance no exceed the limits : 50V

Battery can be added to the system : 48V battery pack connected to original battery pack in parallel pattern .

* Steering column height adjustment

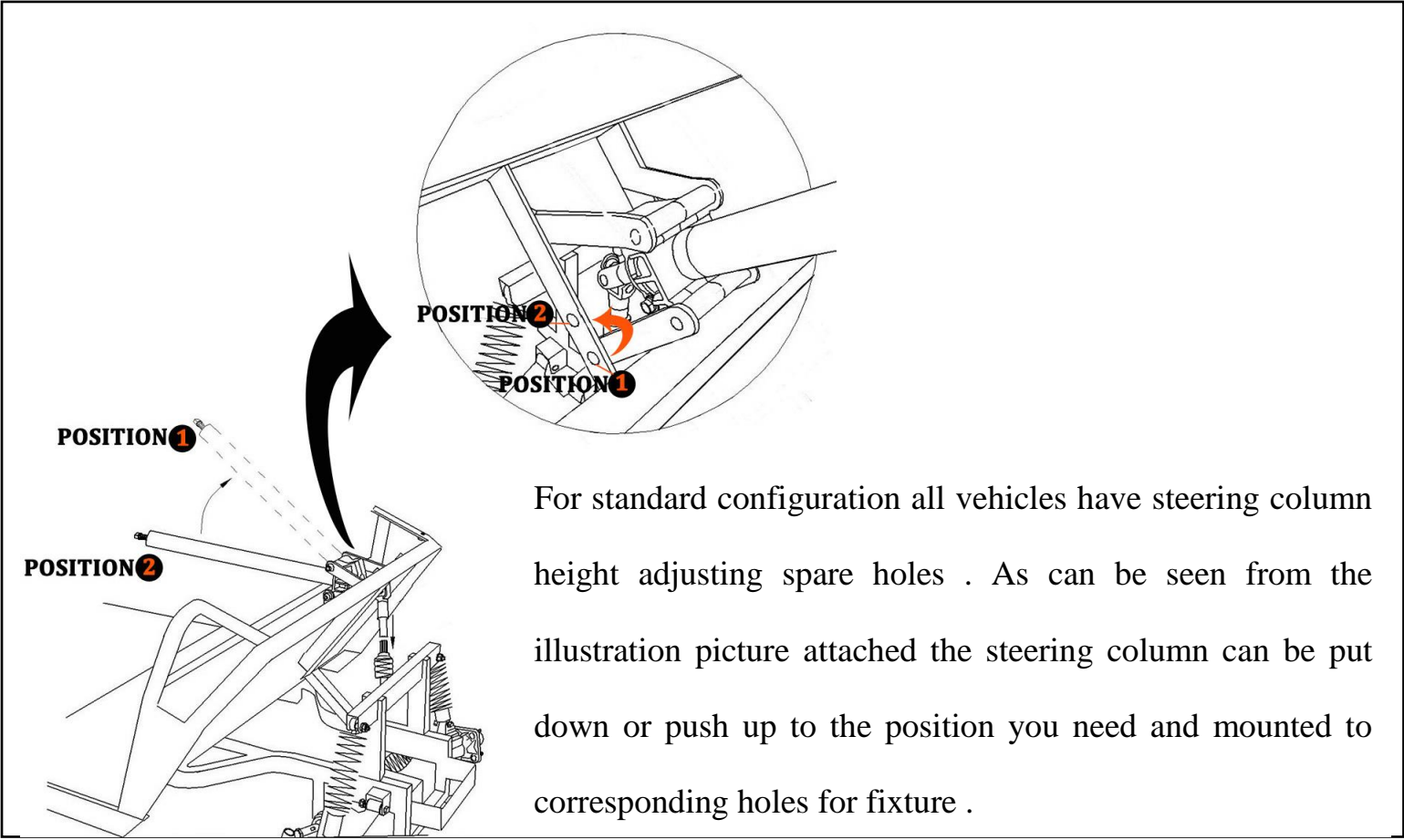

For standard configuration all vehicles have steering column height adjusting spare holes . As can be seen from the illustration picture attached the steering column can be put down or push up to the position you need and mounted to corresponding holes for fixture .

* Steering wheel

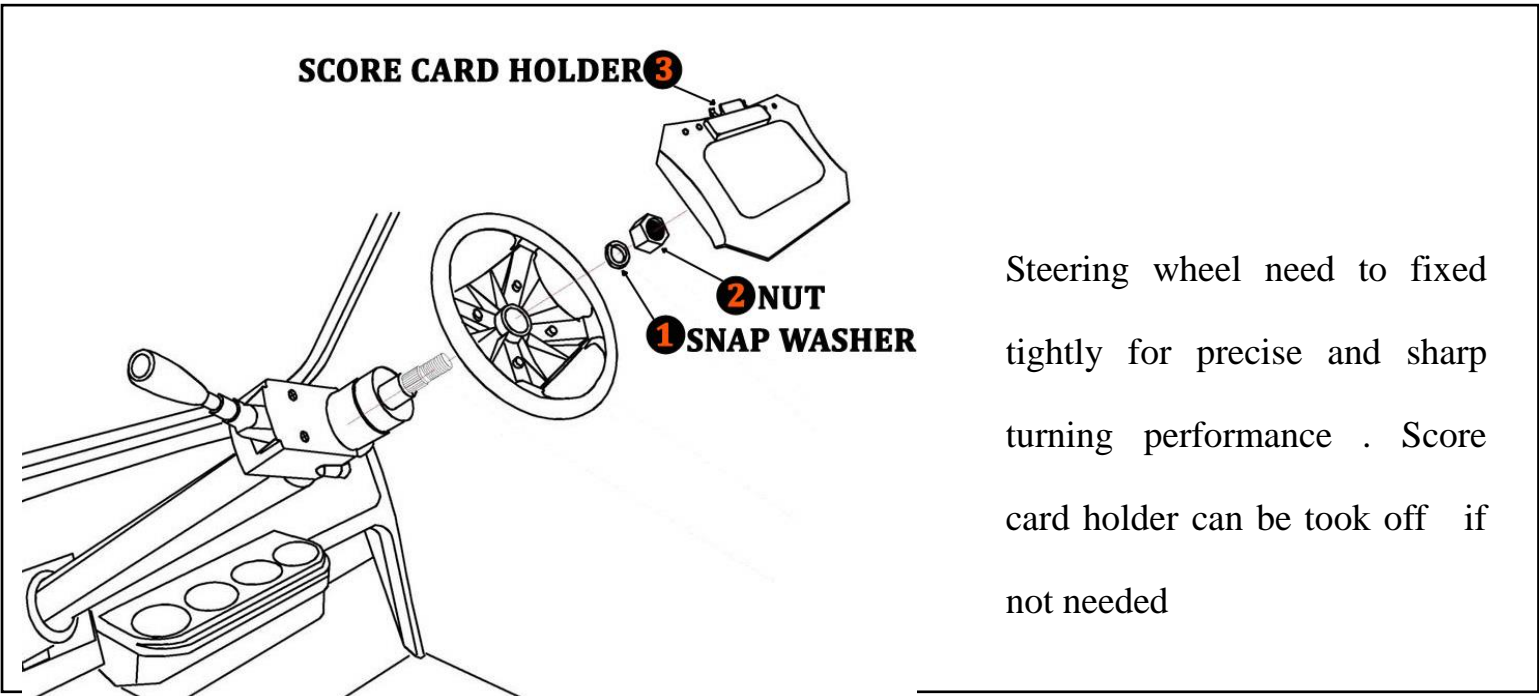

Steering wheel need to fixed tightly for precise and sharp turning performance . Score card holder can be took off if not needed

* Rear axle

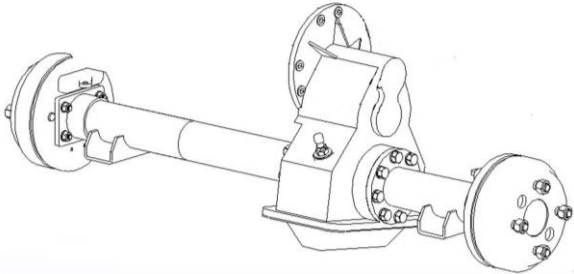

The standard rear axle for the lifted vehicle is 12:1 to increase speed for higher speed performance or reduce speed for bigger torque performance .

Current configuration :12:1 ratios axle

Optional axle ratio : 10:1 for higher speed

16:1 for bigger torque

18:1 for extremely critical areas

* LED Turning signal light

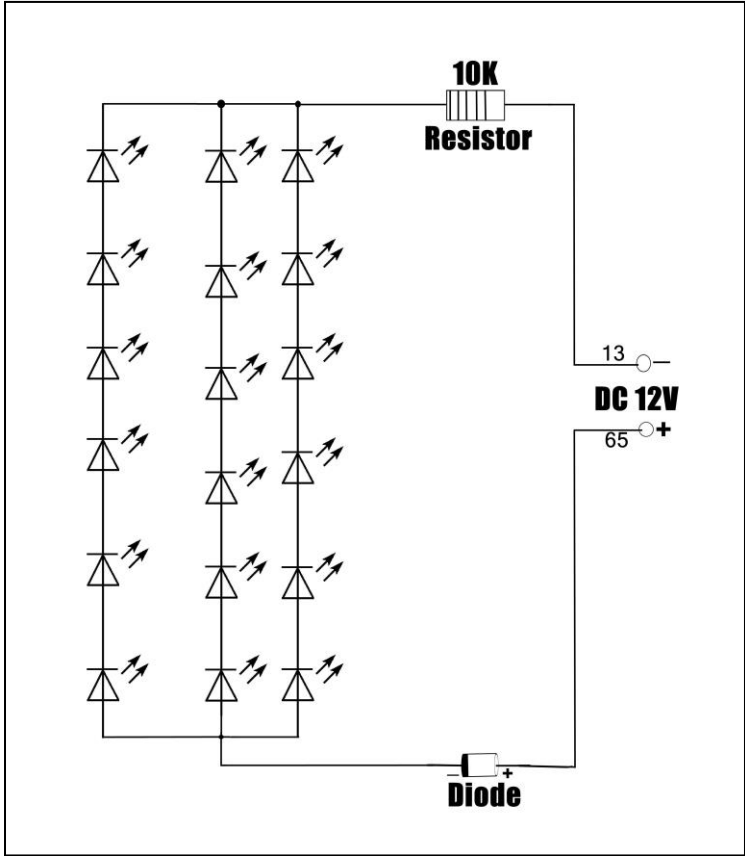

LED rear turning light circuit diagram

* LED brake signal light

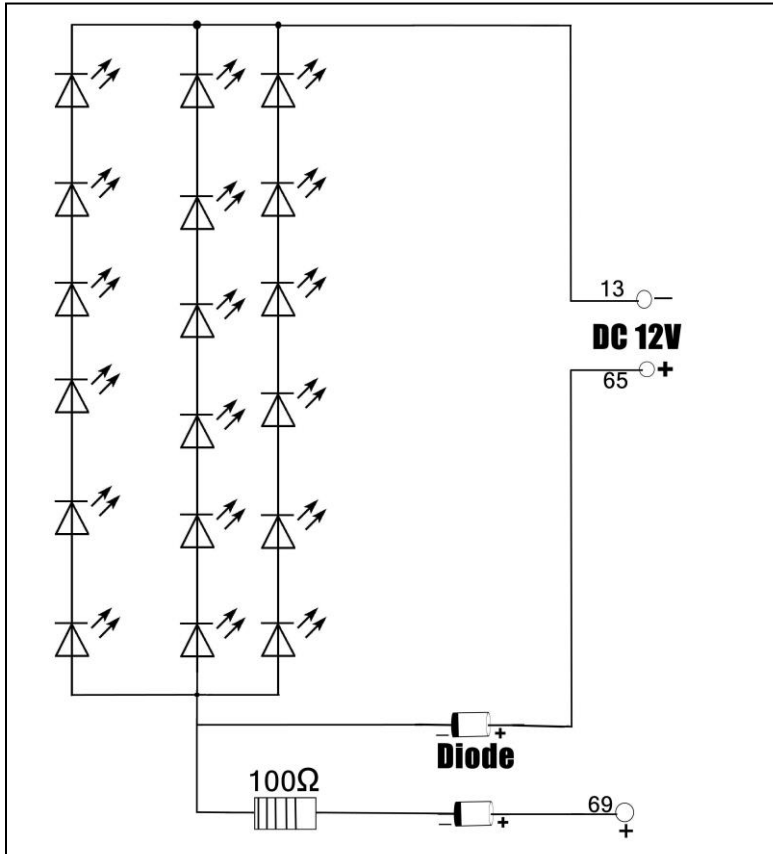

LED rear Brake ight circuit diagram

* Vehicle Tires' tread

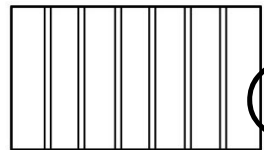

①

For different circumstances the vehicle being used, different tire treads are optional ,the standard tires EVOLUTION vehicles have are turf tires.

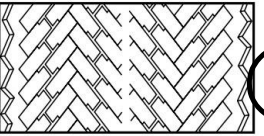

②

FIGURE ① STANDARD TREAD

FIGURE ② PREMIUM TREAD

FIGURE ③ EXTRA TRACTION

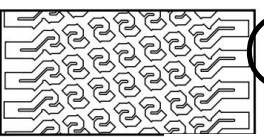

③

! FOR ATTACHING THE MAXIMUM PERFORMANCE THE TIRES SHOULD ALWAYS BE CHOSEN ACCORDING TO THE CIRCUMSTANCES THE VEHICLE MOSTLY BEEN USED .

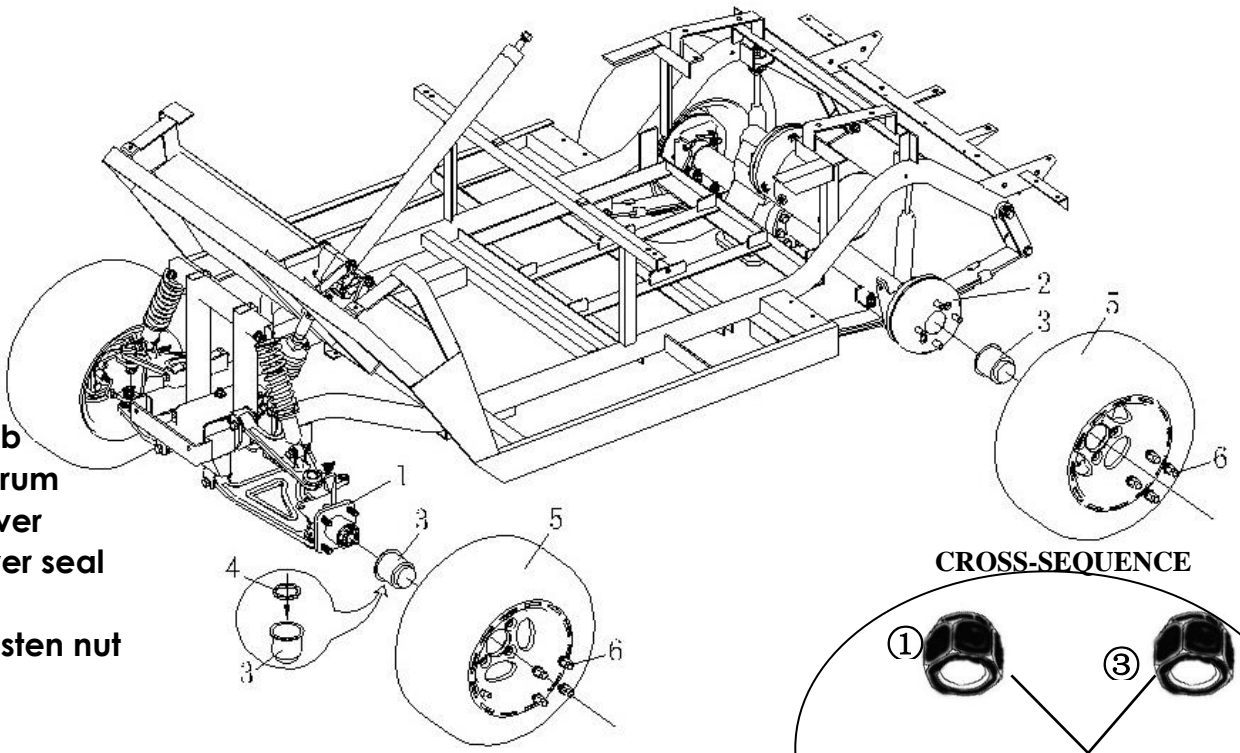

- ① Front hub
- ② brake drum
- ③ Dust cover
- ④ Dust cover seal
- ⑤ Tire
- ⑥ wheel fasten nut

! While fasten the wheel nuts , one should always keep fasten it on in cross-sequence .To attach the perfect tight

! Tubeless tire cautions

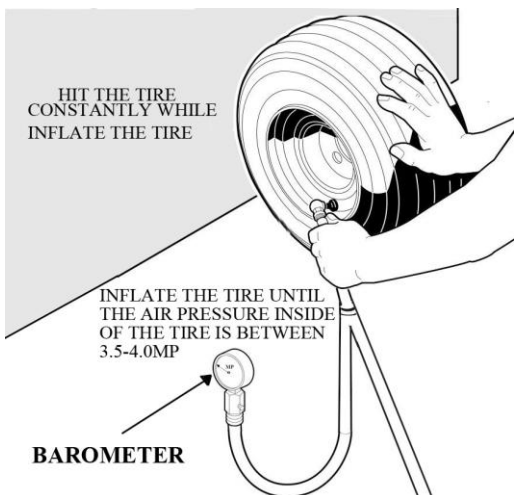

1. Clean both tire beads to remove dirt or other object.
2. Where the tire beads seat, clean the wheel rim with a wire brush
3. Apply plenty of tire mounting lubricant (soap and solution) to both beads and rim flanges
4. Install the tire on the rim from the valve stem side .if there is no tire machine available ,use a rubber mallet and tire iron
5. Remove the valve core and position tire so that both beads are on the rim flange narrow bead seats
6. Quickly remove the air nozzle and install the valve core
7. Adjust the tire ,keep the air pressure between 3.5-4.0MP, immerse the tire into water to make sure there are no leaks

HIT THE TIRE CONSTANTLY WHILE INFLATE THE TIRE

INFLATE THE TIRE UNTIL THE AIR PRESSURE INSIDE OF THE TIRE IS BETWEEN 3.5-4.0MP

BAROMETER

PERIODIC MAINTENANCE CHART



Regular maintenance is required for the best performance and safe operation of the electric vehicle . Periodic maintenance need to perform accordingly .

1D-per day 1W-per week 1M-per month 1Q-per quarter 1Y-per year

Item	Descriptions	1D	1W	1M	1Q	1Y
Maintenance of battery	1.Check the liquid level .Add distilled water in necessary .		√			
	2.Charge the battery .	√				
	3.Tighten or open the nut on the battery cable .	√				
	4. Fasten the nut of the battery electrode .		√			
	5.Check whether the battery is over-charged .	√				
	6.Check the liquid density of the battery .		√			
	7.Check whether the battery is fully charged .	√				
	8.Clean the surface of battery .		√			
Charger	9.Observe the charging status, check if the charger plug becomes hot.	√				
	10.Clean the surface of charger . Do not let water enter into charger .		√			
Motor and controller	11.Check whether all terminals are tightened properly(Turn off the power first).			√		
	12.Clean the surface of the controller.				√	
	13.Check whether the solenoid is in order, checking it's touching point.					√
	14.Check whether there is water get into motor.	√				
	15.Check whether the carbon brush should be replaced .					√
	16. Check whether the accelerator pedal works well .	√				
Chassis and body	17.Check whether the brake pedal is firm and can be released freely .			√		
	18.Check whether the brake drum and brake shoe need to be replaced or not				√	
	19.Check the hand break function.			√		
	20.Check the break liquid tank liquid level .			√		
	21.Check tire pressure and tire surface .		√			
	22.Check Whether the shock .			√		
	23.Fasten the bolt of shaft .			√		
	24.Check whether there is sufficient oil inside of rear axle gear box .				√	
	25.Add grease to front hub and steering gear box .				√	
	26. Adjust the front and rear suspension .				√	
27.Clean the body and seat .	√					

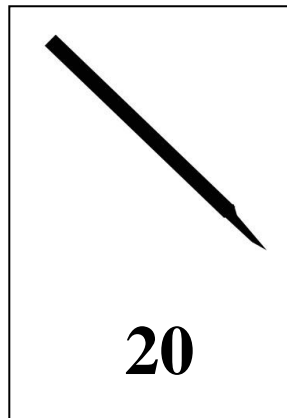
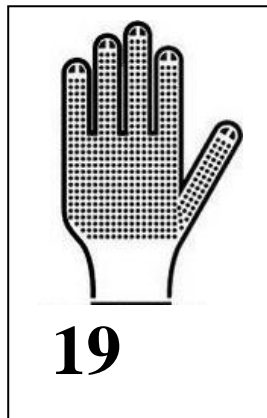
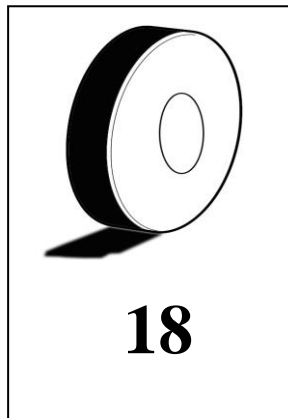
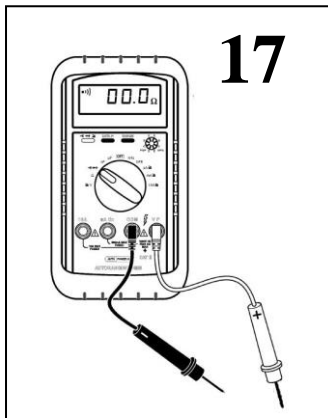
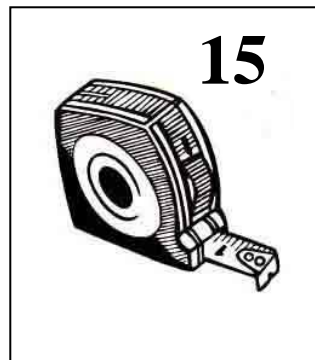
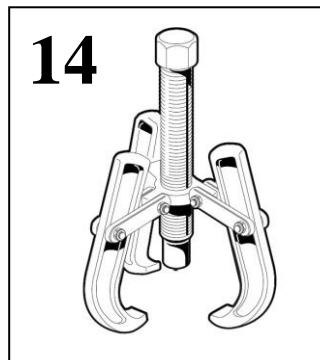
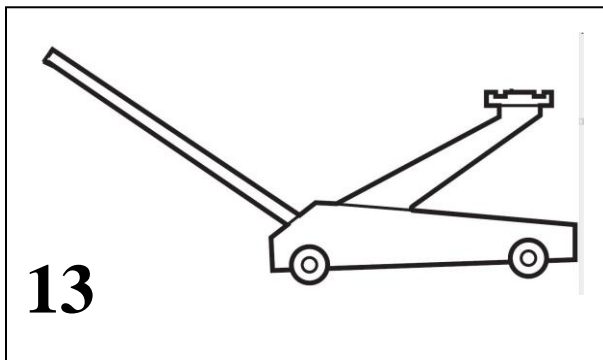
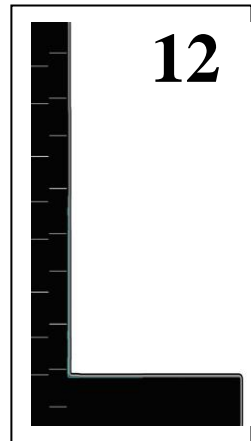
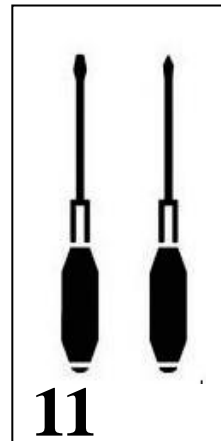
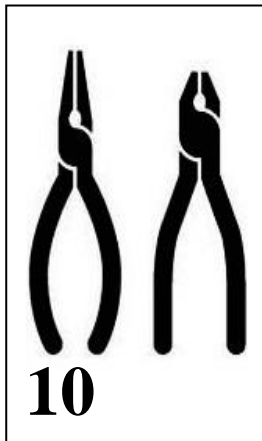
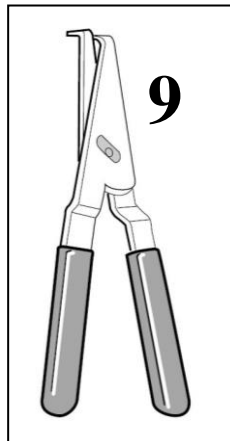
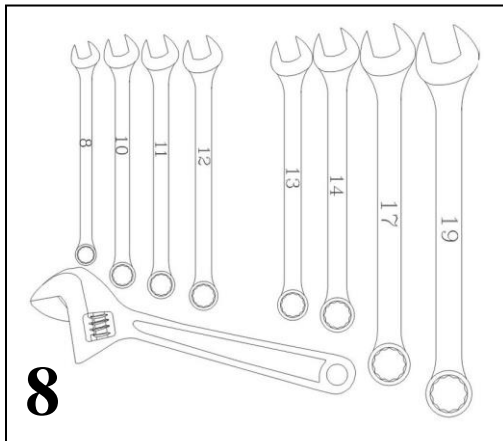
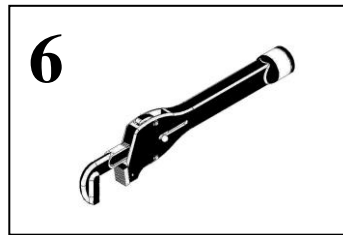
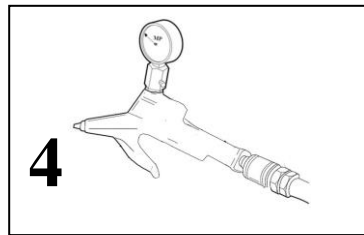
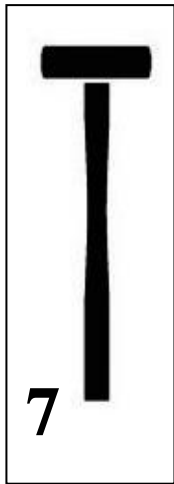
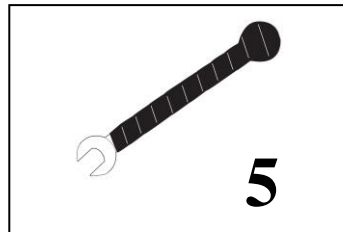
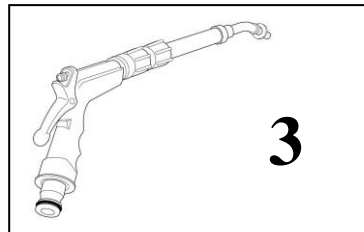
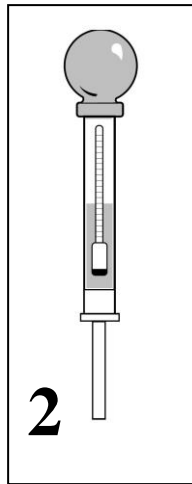

ITEM	DESCRIPTION
1	Curtis Handheld programmer
2	Battery hydrometer (For Lead acid battery only)
3	Distilled water refilling nozzle (For Lead acid battery only)
4	Tire pressure gauge
5	15mm insulated wrench(For battery terminal bolts)
6	Pipe Wrench (For spindle split nut)
7	Hammer
8	Wrench tool pack (from 6mm-22mm)
9	Circlip plier
10	Pliers
11	Philips and flat head screwdrivers
12	Try square
13	Jack
14	Driven clutch cam puller
15	Measurer meter
16	Lubricant
17	Multimeter
18	Insulation tape
19	Insulation grove
20	Pin needle (used for pulling out the wiring harness pins)

VEHICLE MAINTENANCE AND ADJUSTMENT

41



Vehicle maintenance

CAUTION

Always:

- Maintain the vehicle in accordance with the manufacturer's periodic service schedule.
- Ensure that repairs are performed by those that are trained and qualified to do so.
- Follow the manufacturer's maintenance procedures for the vehicle. Be sure to disable the vehicle before performing any maintenance. Disabling includes removing the key from the key switch and removal of a battery wire.
- Insulate any tools used within the battery area in order to prevent sparks or battery explosion caused by shorting the battery terminals or associated wiring. Remove the batteries or cover exposed terminals with an insulating material.
- Check the polarity of each battery terminal and be sure to rewire the batteries correctly.
- Use specified replacement parts. Never use replacement parts of lesser quality.
- Use recommended tools.
- Determine that tools and procedures not specifically recommended by the manufacturer will not compromise the safety of personnel nor jeopardize the safe operation of the vehicle.
- Support the vehicle using wheel chocks and jack stands. Never get under a vehicle that is supported by a jack. Lift the vehicle in accordance with the manufacturer's instructions.
- Maintain the vehicle in an area away from exposed flame or persons who are smoking.
- Be aware that a vehicle that is not performing as designed is a potential hazard and must not be operated.
- Test drive the vehicle after any repairs or maintenance. All tests must be conducted in a safe area that is free of both vehicular and pedestrian traffic.
- Replace damaged or missing warning, caution or information labels.
- Keep complete records of the maintenance history of the vehicle.

The manufacturer can not anticipate all situations, therefore people attempting to maintain or repair the vehicle must have the skill and experience to recognize and protect themselves from potential situations that could result in severe personal injury or death and damage to the vehicle. Use extreme caution and, if unsure as to the potential for injury, refer the repair or maintenance to a qualified mechanic.

I .Chassis

i Steering system maintenance

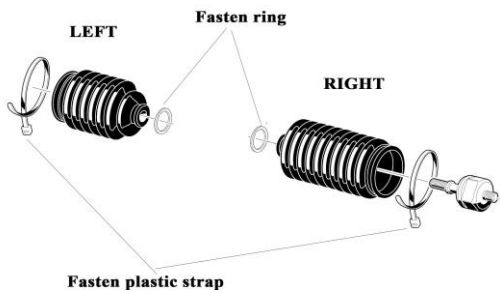

Check the dust-proof caps on steering gear box ,the caps are supposed to be tight on the two terminal ends .
Loose caps will let water and dust into the gear box ,cause the gears rusting .



Add lubricant to mechanical joint parts , the vehicle should be kept in good turning and operating functions . To attach that one should add lubricant to needed parts every one month .

①.To assure the steering system in proper function all the mounting nuts and fasten rings should be solid tight .

②. The steering wheel should be installed on the spline of the steering shaft, making sure to align the match marks placed on the wheel and steering column.

While operate the steering wheel one should stop turning when it comes to the dead end of the turning angle ,otherwise may damage the steering wheel cause the nut to strip .

③ The dust cover on the universal joint or and the steering box should be kept in perfectly tight to keep dust or other foreign objects and water to enter inside of the mechanical parts

④The joint parts of the steering system or the connection spot should add lubricant per month to keep the joint part ,shaft perfectly smooth

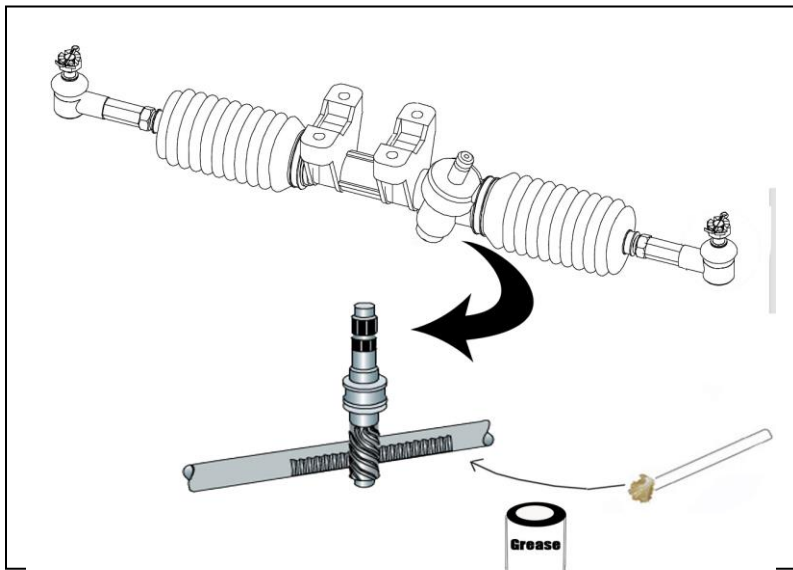

Check the dust-proof caps on steering gear box ,the caps are supposed to be tight on the two terminal ends .
Loose caps will let water and dust into the gear box ,cause the gears rusting .

Maintenance period : one per 12 months .

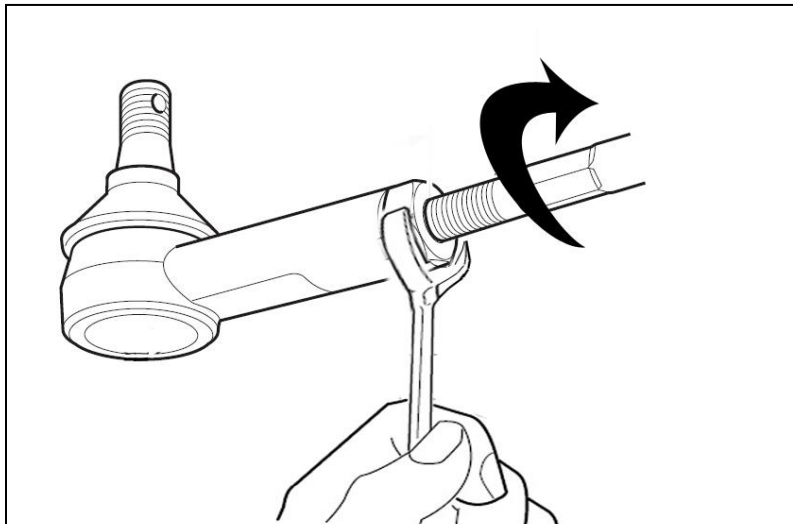

Check the tightness of the tie rod adjusting bolt ,make sure the restraint nut is securely tightened .
Loose nut will lead to wrong camber angle causing steering malfunction and uneven wear out tires

Maintenance period : one per 3 months .

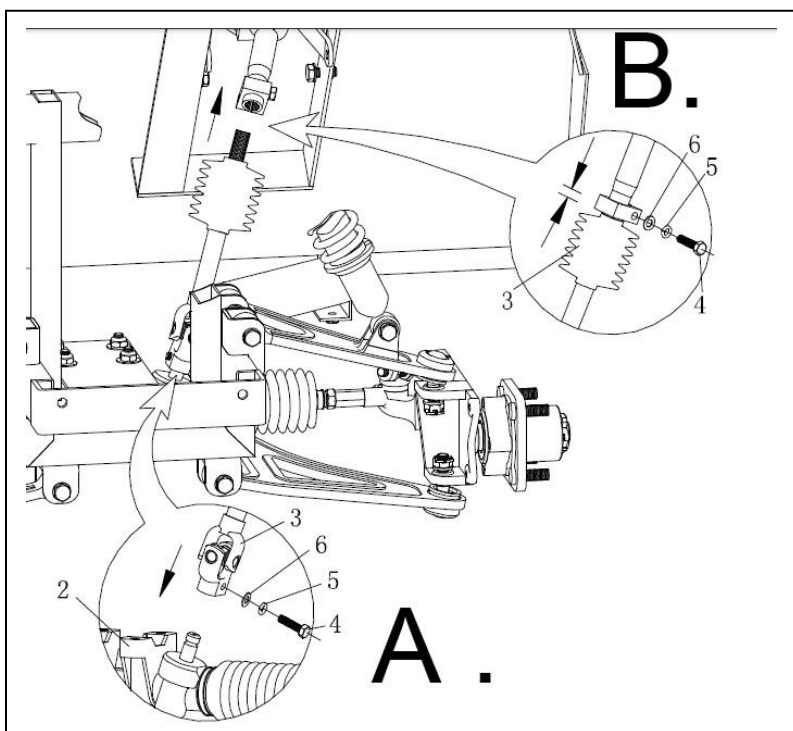

Tight the cardan joint bolt to make sure all the bolts are tightened (not too tight).

Loose cardan joint will cause steering shaking .

Maintenance period : one per 2 months .

ii Front suspension

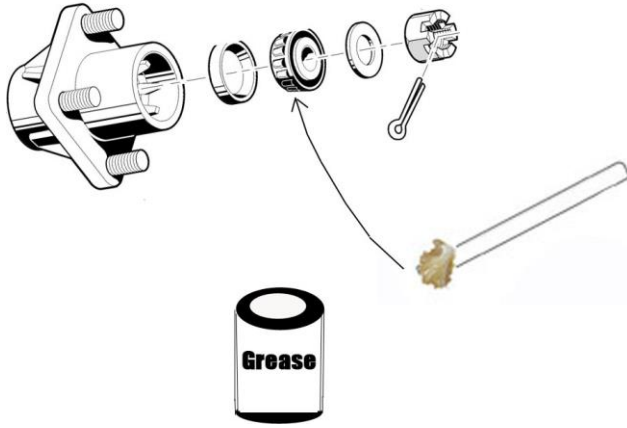

Check the bearings inside of front hub , the hubs should have enough lubricated grease .

Maintenance period : one per 6 months .

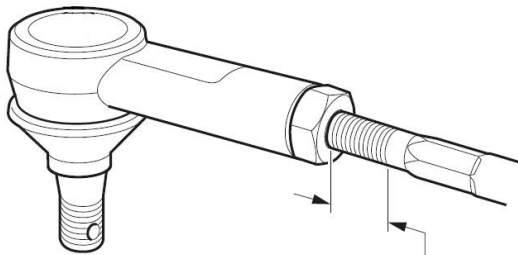

Measure exposed thread length and use length to position new ball joint at same location

Measure exposed thread length and use length to position new ball joint at same location for both sides

Maintenance period : one per 3 month .

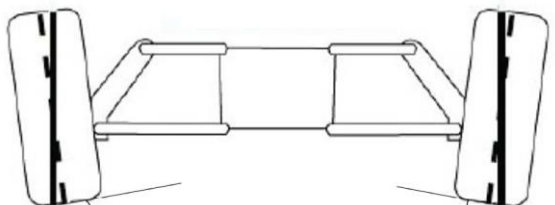

Intersection angle

Adjust the intersection angle of tire . make sure the tire angle does not exceed 2 degree .

Maintenance period : one per 6month .

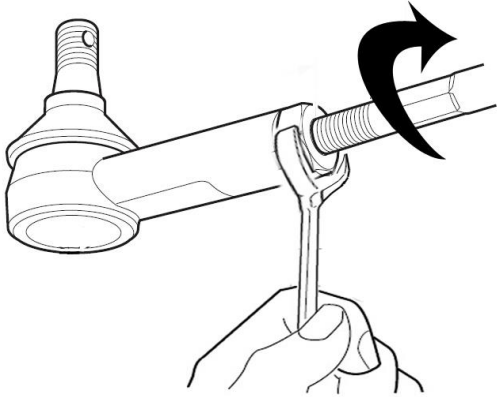

Check the tightness of the tie rod joint nuts on both side . check the toe-in scale of the wheels .

Maintenance period : one per 3 months .

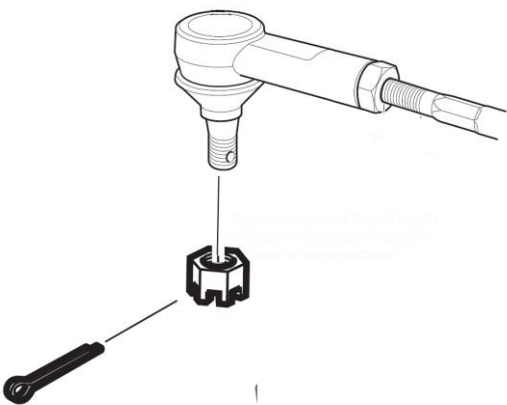
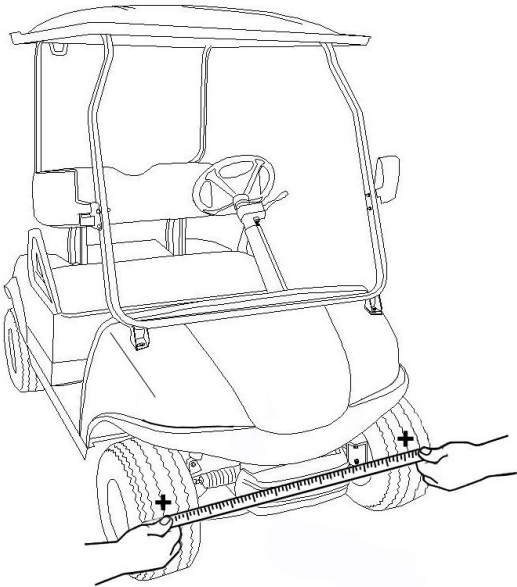

Check the tightness of the tie rod joint nut .

Loose nut will cause severe tire wearing and shock absorbing problems .

Maintenance period : one per 3 months .

iii. Rear axle & brake

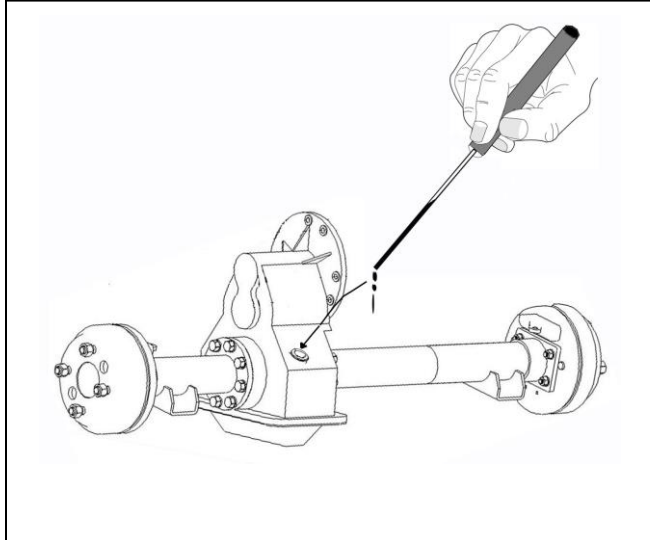

Check the lubricant capacity of rear axle .
Low lubricant capacity may cause damages to rear axle cams or excessive noises .

Maintenance period : change the lubricant of rear axle every 6 month .

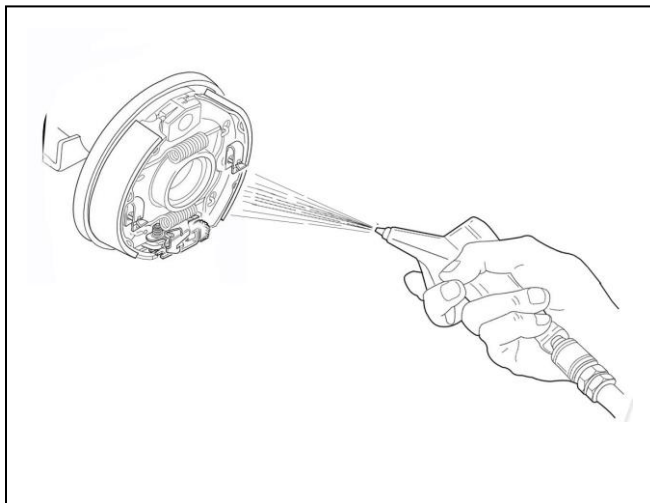

Clear the brake shoes surface , all the brake shoes shred dust should be cleaned out in periodic time .
Shred dust may cause mechanical malfunctions of brake .

Use a compressed air to blow the dust out .

Maintenance period : one time per month .

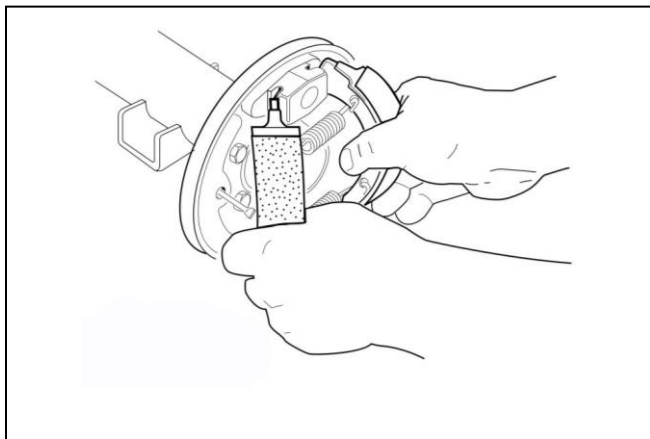

Check the brake shoes worn out conditions , if it is extremely worn out(1/3 left) ,then the brake shoes need to be replaced with a new one

 **DANGEROUS**

DO NOT DRIVE THE VEHICLE WITH POOR BRAKE .

VEHICLE MAINTENANCE AND ADJUSTMENT

47

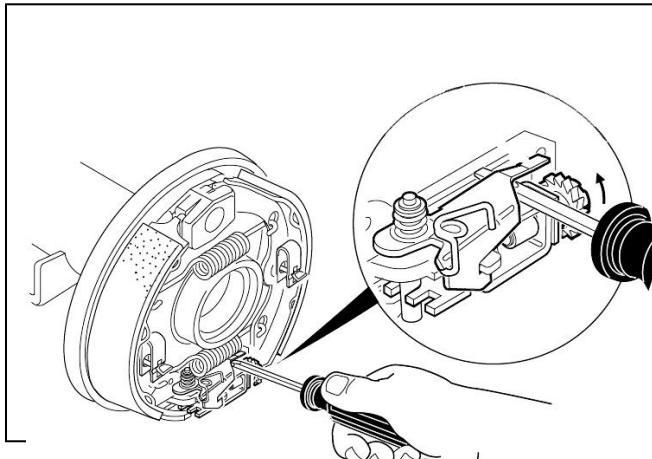

Adjust the tightness of the rear brake shoes .

Maintenance period : one per 6 months .

 **DANGEROUS**

DO NOT DRIVE THE VEHICLE WITH POOR BRAKE .

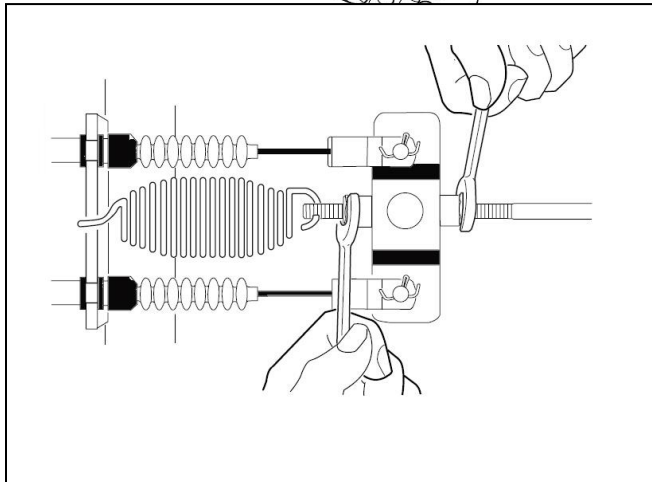

Adjust the brake balance block ,make sure the block is in normal position to ensure the vehicle has even brake on both sides

Maintenance period : one per 6 months .

 **DANGEROUS**

DO NOT DRIVE THE VEHICLE WITH POOR BRAKE .

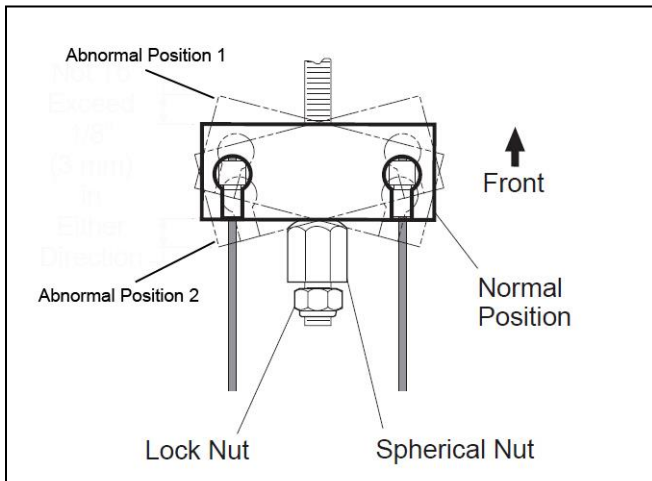

Check the brake cable fixture pins with brake assembly. Make sure the pin is good condition

Maintenance period : one per 12 months .

 **DANGEROUS**

DO NOT DRIVE THE VEHICLE WITH POOR BRAKE .

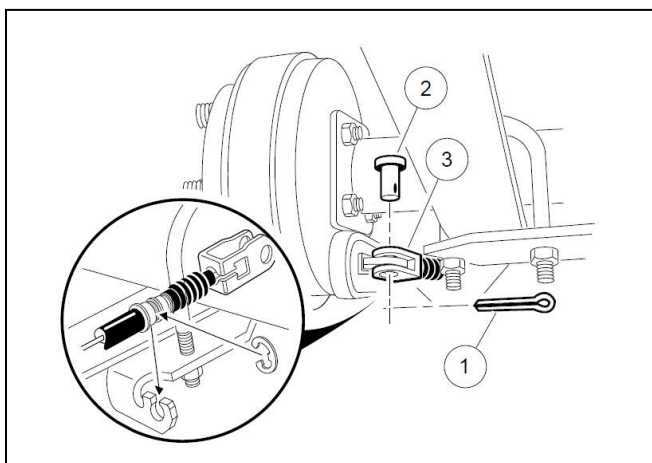

iii. Tires

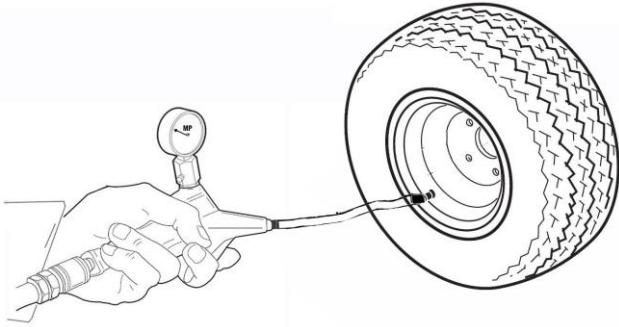

Check the tires every time use the vehicle . the tires should be inflated with enough air . The air pressure should with normal level . Check the tire chapter for more specific information of tire inflation .

WARNING

FLAT TIRE MAY CAUSE UNSTABLE STEERING FUNCTION WHILE DRIVING .

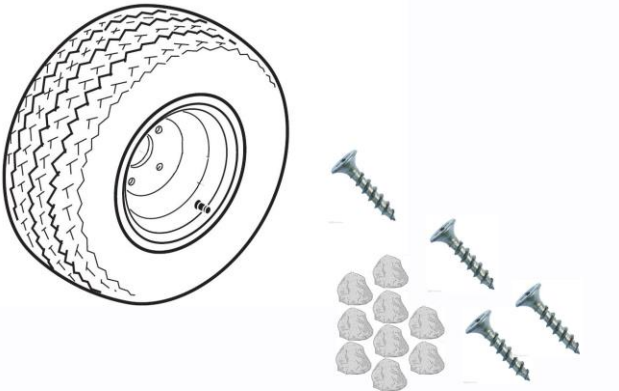

Check the tires every time use the vehicle , remove embedded objects or metal items away from tire surface .

If the tire have embedded objects on surface ,it will lead to excessive noises from tire while driving or tire internal air leaking .

iv. Battery

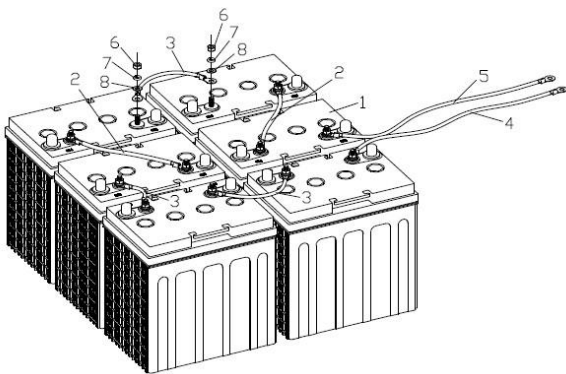

Check the tightness of battery connection cables ,make sure there are no loose connections or extremely oxidized terminals .

Maintenance period : One time per week

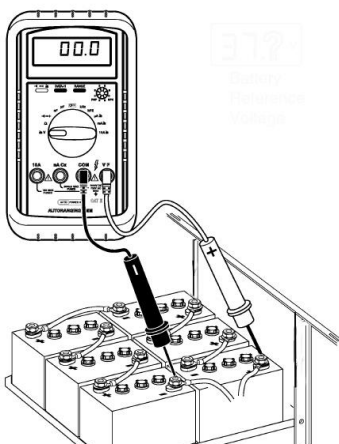

Check the battery pack voltage and voltages of every single battery unit make sure the voltage is bigger than rated value

Maintenance period : One time per month

VEHICLE MAINTENANCE AND ADJUSTMENT

49

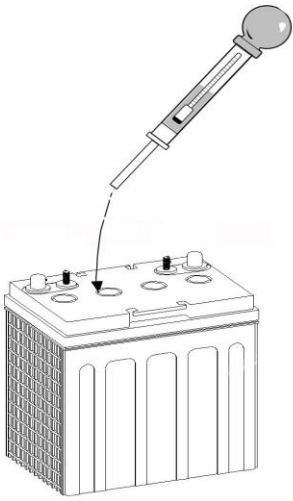

Use a hydrometer to check the specific gravity of the battery fluid in each cell.

Fluid density ranges from different values in different period of battery using .

Maintenance period :One time per week .

(Flooded/wet batteries ONLY)

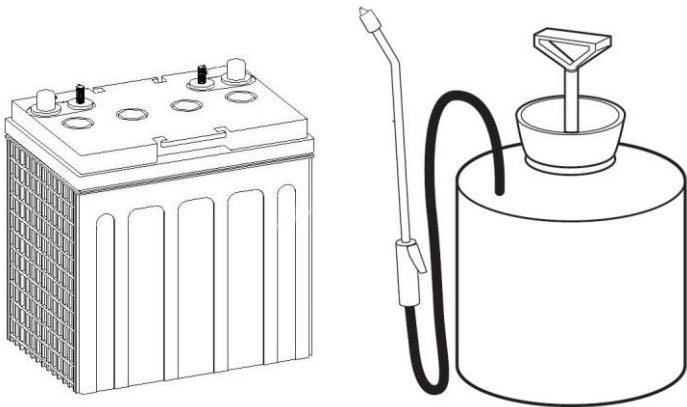

Use a injection faucet to inject distilled water into the battery when the battery don't have enough capacity of battery fluid .

Maintenance period : One time per week .

(Flooded/wet batteries ONLY)

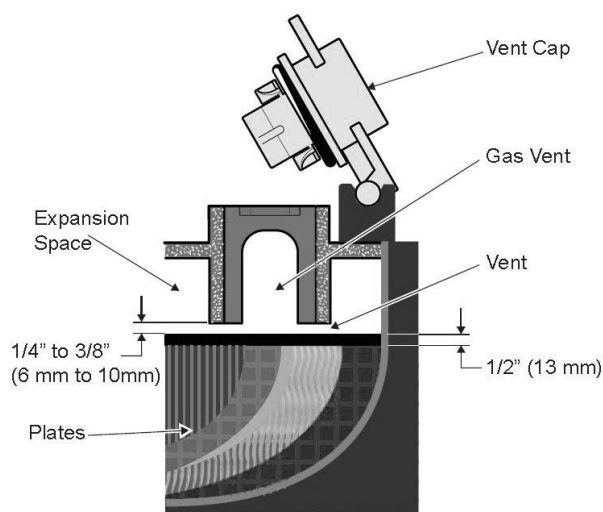

Check fluid level before and after charging , electrolyte should be at least 1/2"(13mm)above the plates and 1/4" tp3/8"(6 to 10mm) below bottom of the vent .

(Flooded/wet batteries ONLY)



NEVER CHARGE BATTEY WITH LITTLE ELECTROLYTE , IT MAY CAUSE OVERHEATED OR EVEN EXPLOSION

v. AC Motor

Speed Encoder For AC Motor

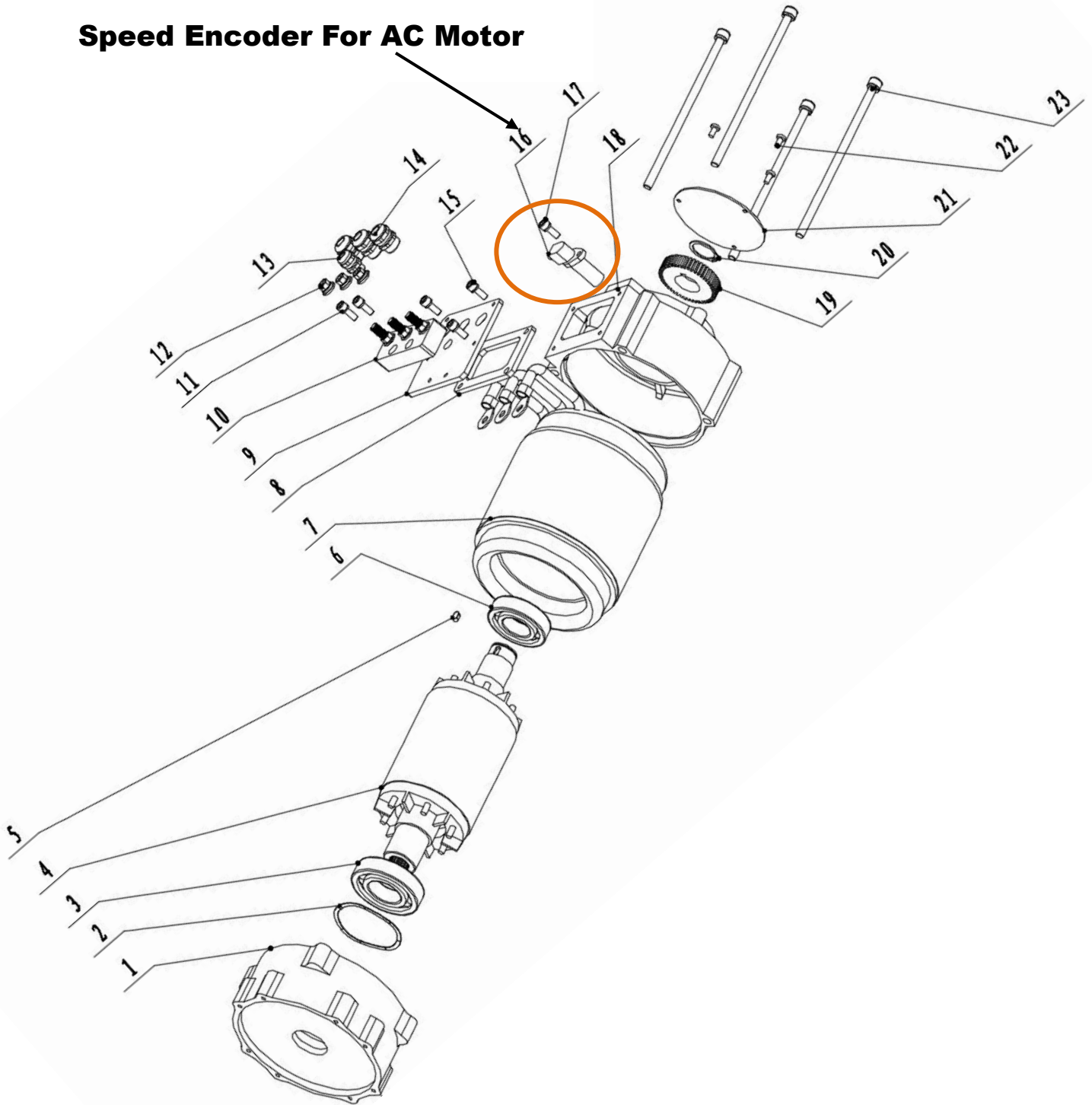

VEHICLE MAINTENANCE AND ADJUSTMENT

51

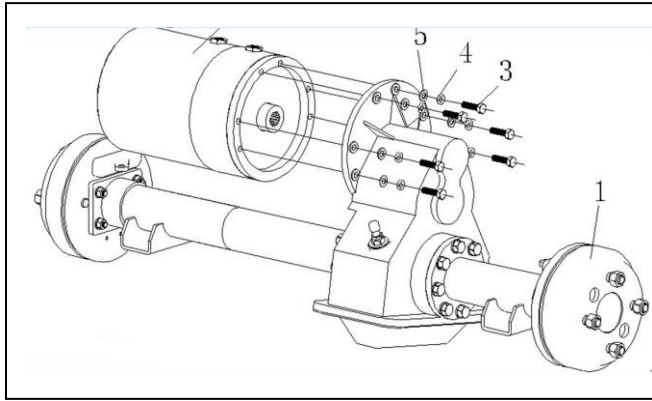

Check the tightness of motor mounting bolts and motor electric cables , make sure there are no loose bolts or loose cables .

Maintenance period : One time per month

⚠ CAUTION

DO NOT DISASSEMBLE THE REAR AXLE OR MOTOR UNLESS YOU ARE PROFESSIONAL .

iv. Other electric component

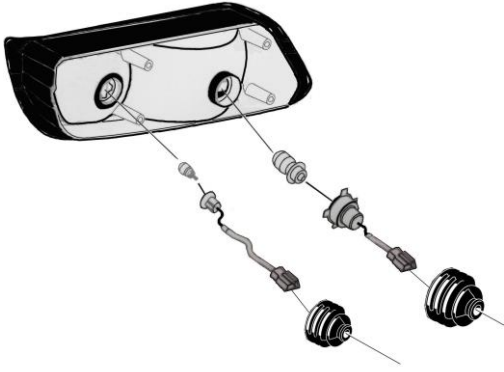

Check the headlight back rubber caps , the caps should always be kept on tightly . otherwise water or dust may enter into the headlight chambers . Cause halogen bulbs burn down easily and vague vision of headlights .
Maintenance period : One time per week



Keep LED rear lights waterproof , keep the cover lid tight ,keep dust and water out of LED light assembly . Dense humidity or water may cause LED diodes to burn down .

⚠ CAUTION

DO NOT LOAD LED LIGHTS WITH HIGH VOLTAGES .



Keep the controller from water , water may cause circuitry short circuit . If water enter into controller , the vehicle may run unintentionally after turn on the power switch.

⚠ CAUTION

DO NOT SLASH WATER ON CONTROLLER INTENTIONLLY WHILE WASH THE VEHICLE .



* How to eliminate the malfunctions?

According to the features of the vehicle system , here are the rules that persons intend to operate on the defective cars should follow :

- Always keep only authorized ,trained person to operate on the broke down vehicle.
- Always keep contact with EVOLUTION factory or dealers when have problems that you can not fix .EVOLUTION company have after sales service personnel stand by for your service all the time
- Always have at least one handheld programmer(Type : CURTIS 1313-4001) available for using . Currently all the EVOLUTION vehicles are using CURTIS controller ,for programming the controller or quick diagnose the circuit problem .
For CURTIS controllers that the EVOLUTION vehicles using all the main circuit problems have faulty codes .
One can always use the handheld programmer to change the parameters of the controller, for attaching different performance or for using in different circumstances .
One can always use the handheld programmer to diagnose out the problems and use the trouble shooting table as contrast . The contrast table will tell you which part of the circuit show be checked or replaced .
- Always have enough repairing tools available for testing or repairing .
- Always keep enough vehicle repairing components for storage .
For EVOLUTION vehicles all the components are strictly designed to be highly durable .The most likely break down components are listed and customers should have enough of the these components for replacing the faulty ones .
- Always Use replacing components form manufacturer only .
- Always follow the operation instructions from manufacturer .

WARNING

1. DO NOT TRY TO OPEN UP THE CONTROLLER .
2. DO NOT TRY TO OPEN UP THE ON BOARD CHARGER .
3. DO NOT TRY TO CHANGE THE CIRCUITRY WITHOUT THE AUTHORIZATION OF THE MANUFACTURER , ILLEGAL MODIFICATION MAY CAUSE SEVER DAMAGE TO THE VEHICLE .

ELECTRONIC PART

35pins connector for AC controller

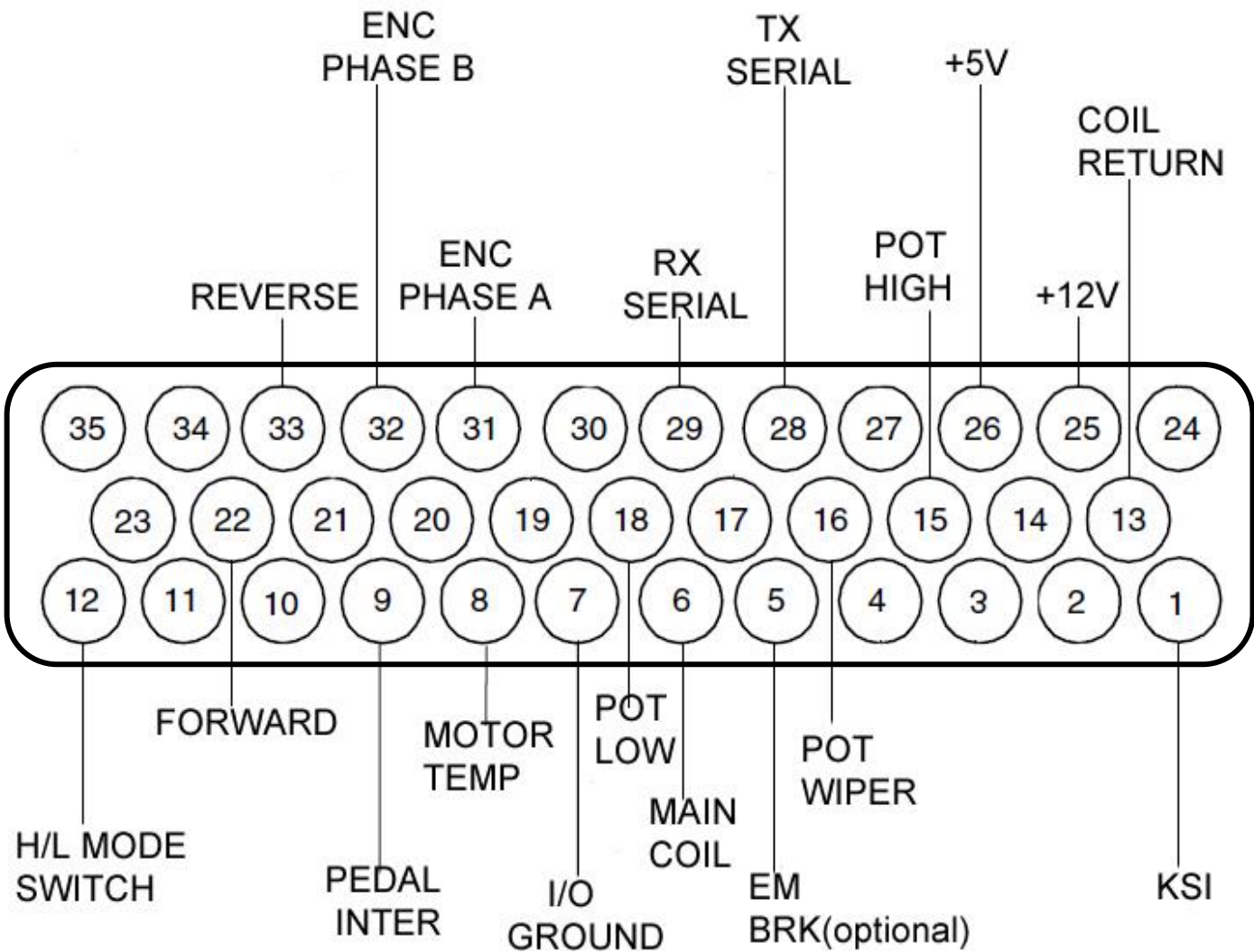

.Controller panel

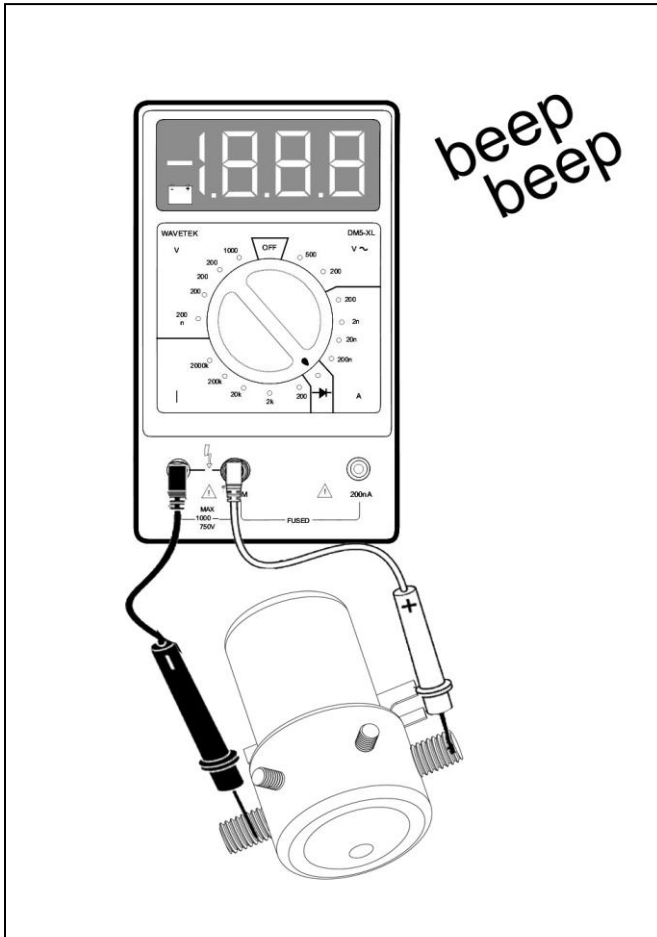
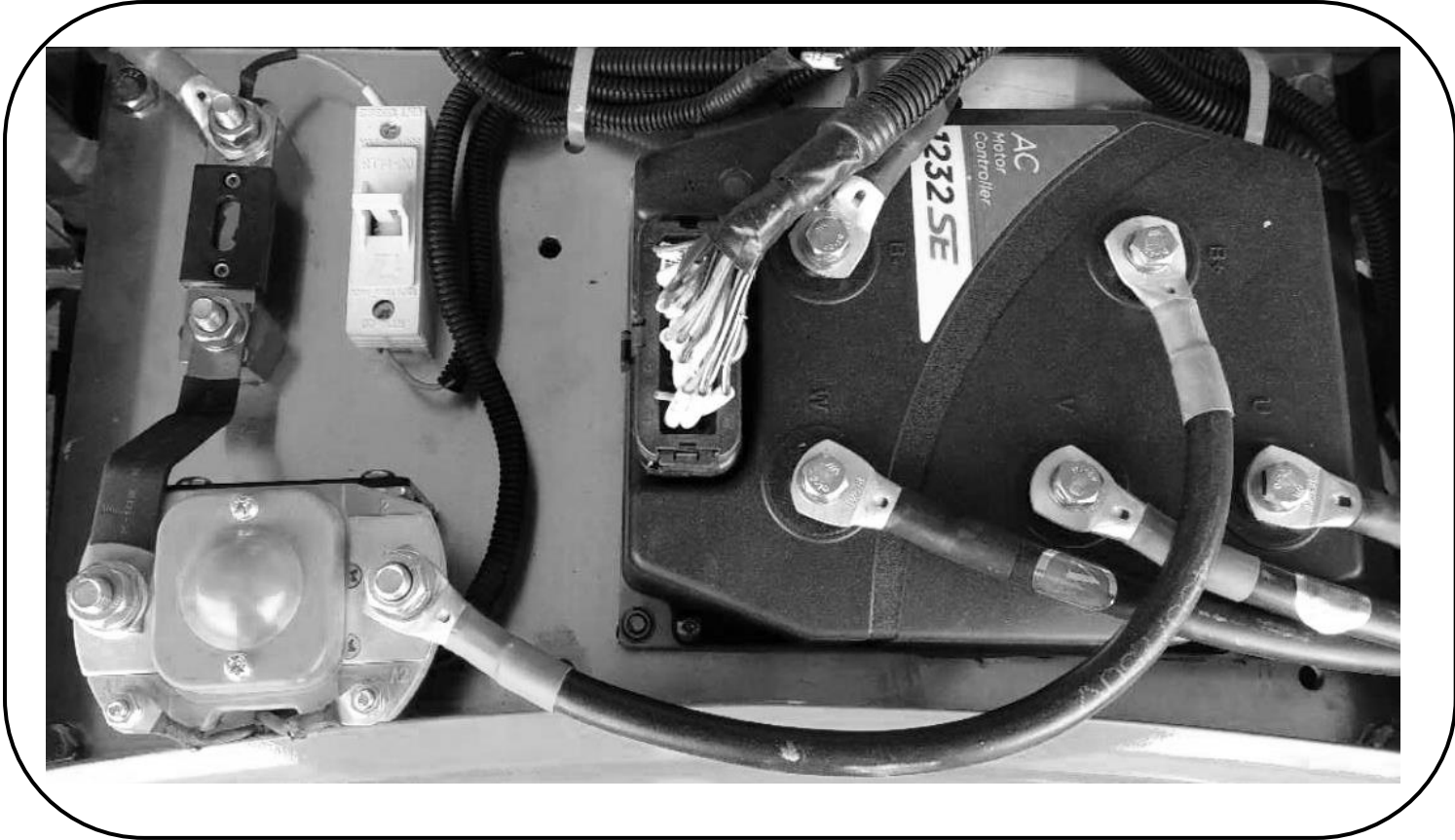

Check the continuity of the solenoid with a multimeters.
Open circuit contact of solenoid should be good solenoid judgment scale.

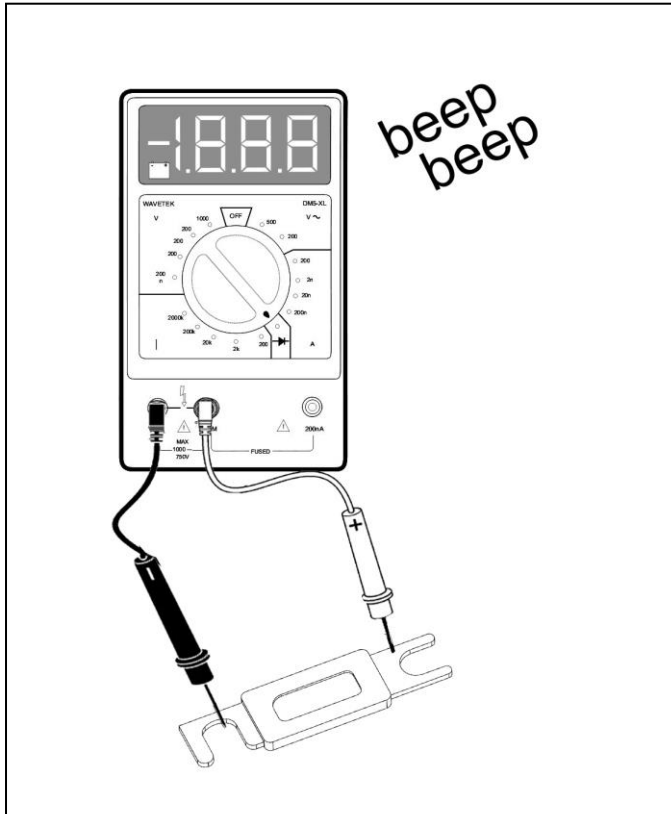

**Check the continuity of the fuse .
Blew off fuse will not have any responds .**

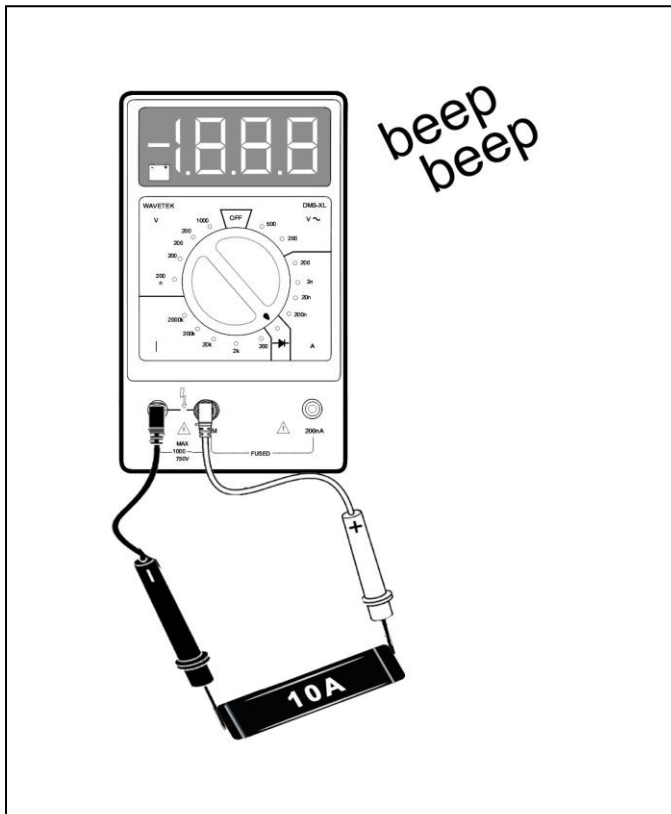

**Check the continuity of the fuse .
Blew off fuse will not have any responds .**

HOW CAN YOU TEST ELECTRONIC COMPONENTS ?

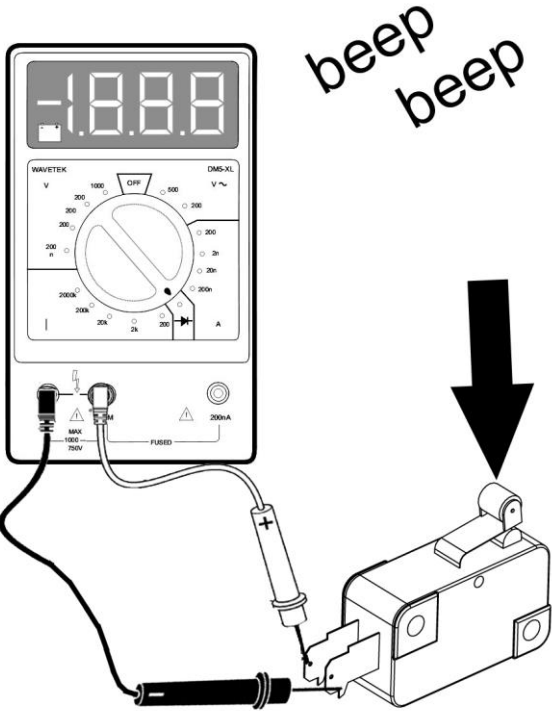
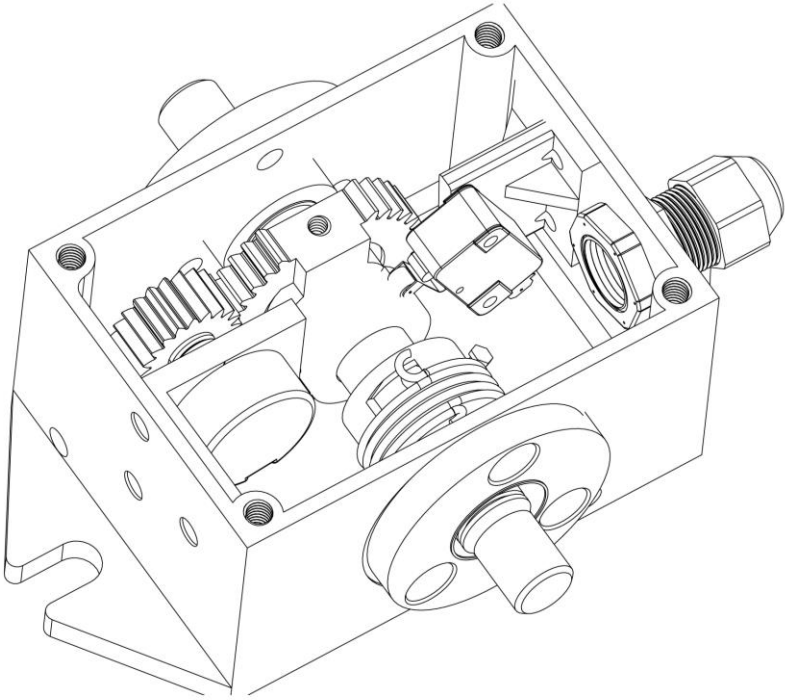

Use the multimeter to check the function of micro switch , press the activation switch and check the continuity of the switch .
Consistent contact of switch when press the switch should be scales to decide the switches .

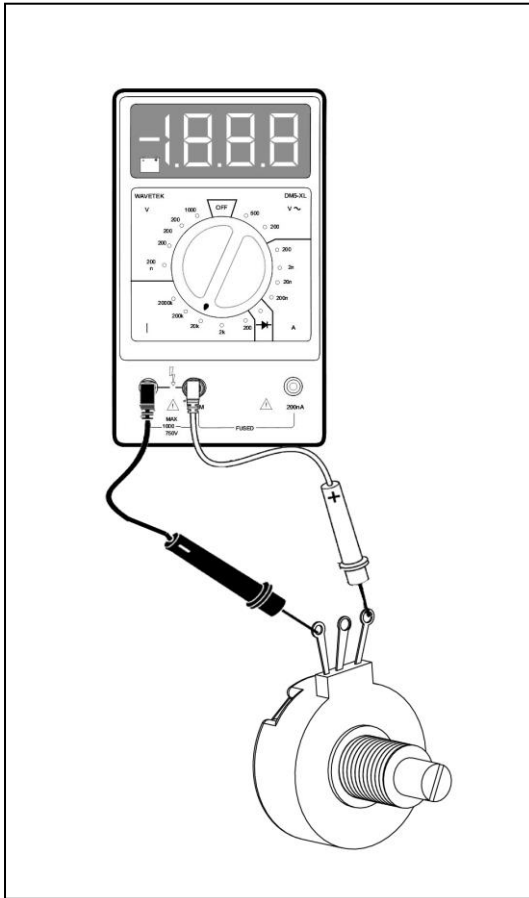

Use multimeter to measure the resistance of the 0-5K POT .

Resistance between side pins should be solid 5K value

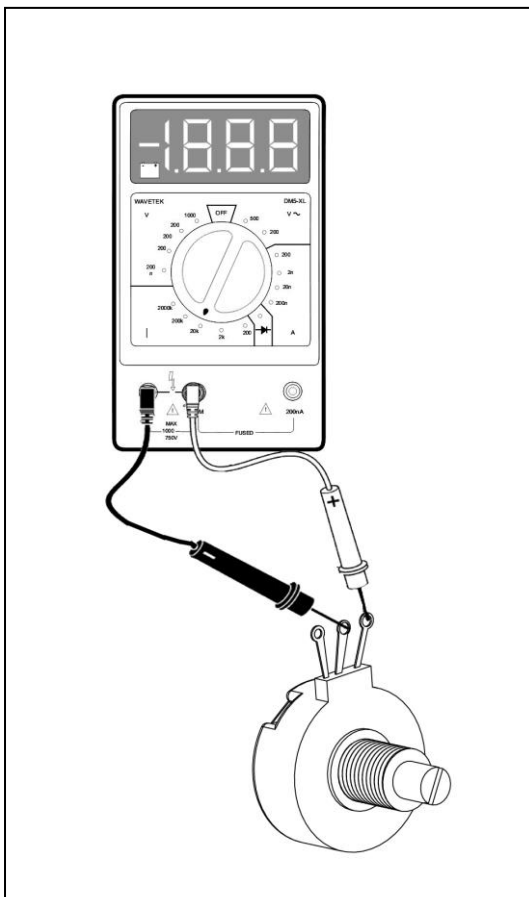

Use multimeter to measure the resistance of the 0-5K POT

Resistance between middle pin and side should ranges fr

0-5K when rotate the shaft . ①

.How to work on wiring harness

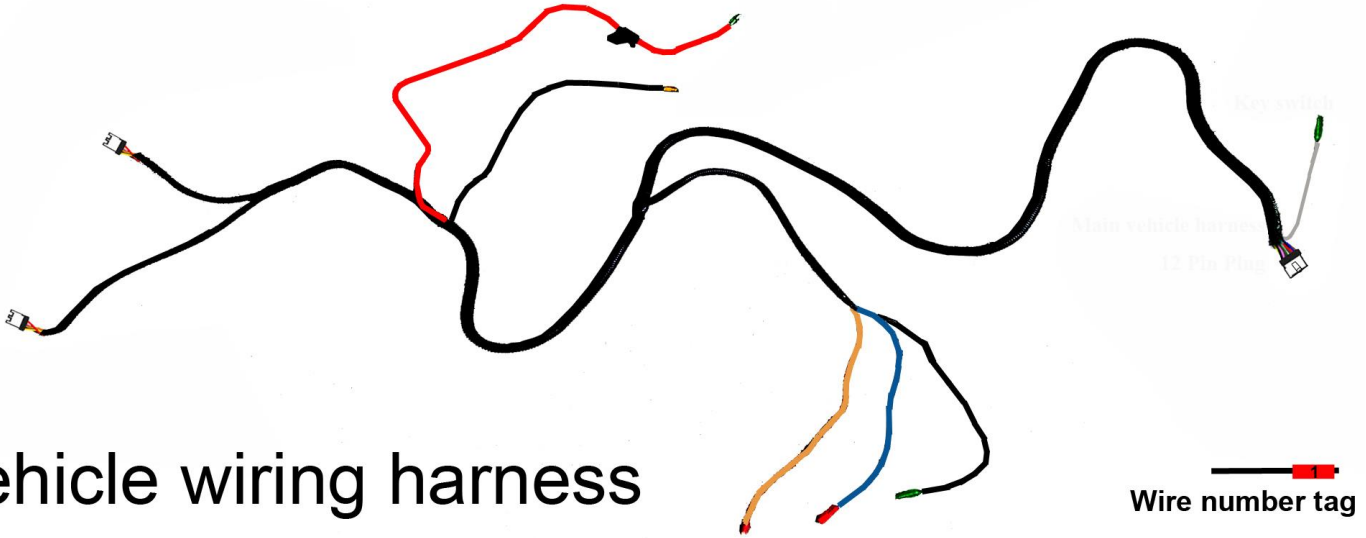

For easily identify the different cable and connectors all the connectors and cables have different color cables attached all the cables have number tag on it to indicate the same cables leads to different locations .

Refer to the diagram and wiring harness diagram to route the cables and find the cables you need .

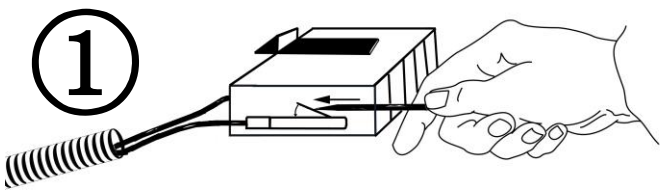

To pull out the connector pins ,use a pin to tuck in the connector to press the restraint hook as shown in picture

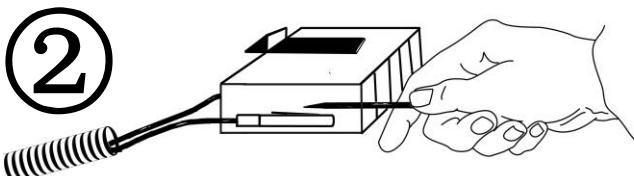

Press the hook to completely flat .

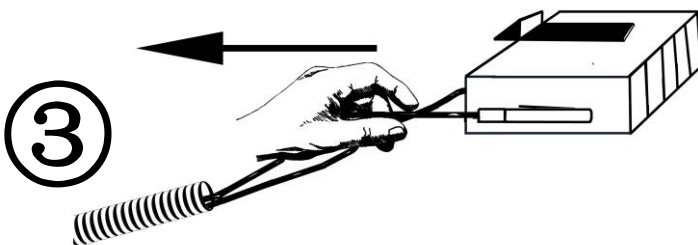

After the hook been pressed to flat then the pins can be pulled out .

The Curtis 1313 handheld programmer is used to configure Curtis motor control systems. With the programmer, you can adjust and save parameter settings, monitor real-time data, and perform diagnostics and troubleshooting.



High-resolution color LCD display. . .

Bright 45×60mm screen is easy to read, providing information at a glance. In addition to menu-specific content, it continuously shows time/date, connection status, and access level.

Easy navigation . . .

Screen displays and the programmer's key layout are designed to work together to provide intuitive navigation.

Convenient parameter adjustment . . .

You can easily adjust a wide range of parameters to customize vehicle performance. These settings can then be saved as a unique.cpf file and stored. Multiple.cpf files can be stored and restored as needed.

Real-time monitoring . . .

Values of monitored data variables are displayed in easy-to-read formats.

Diagnostics and troubleshooting . . .

Existing faults as well as all the accumulated faults in the system's fault his-

tory file are listed in clear language. Suggestions for clearing each fault are also provided.

Plot and Log . . .

The plot and log programs allow you to look at variables over time, either in graphical format or as data files you can upload in a spreadsheet program, such as Excel.

Softkeys . . .

Three versatile softkeys provide multiple functions, depending on context.

Help function . . .

Help screens give descriptions of adjustable parameters, monitored variables, and faults.

PC interface . . .

Files can be downloaded from a PC (onto an SD card or into the programmer directly through its USB connector) for installation into the controller.

Update . . .

The handheld programmer can update its own software.

SD-card support . . .

An SD card provides additional memory capacity. This is where any screenshots you take will be stored. SD cards can be used to deliver software upgrades, and can be used in multiple programmers to install identical software.

Batteries . . .

Two AA batteries provide power for use without a connected system; they also ensure that the programmer's real-time clock keeps running.

Favorites . . .

The Favorites function allows you to create shortcuts to your frequently-used adjustable parameters and monitor variables.

WARNING : The control system can affect speed, acceleration, deceleration, dynamic stability, and braking. If the control system is programmed incorrectly or outside the safe limits as determined by the vehicle manufacturer, it can create a dangerous situation. Only the vehicle manufacturer or an authorized service agent or dealer should program the control system.

PROGRAMMER OPERATION

This section describes how to use the handheld programmer.

Connections

The programmer has two connectors, one for communicating with the motor controller and one for interfacing with a PC. It also has a battery compartment and a memory card slot.

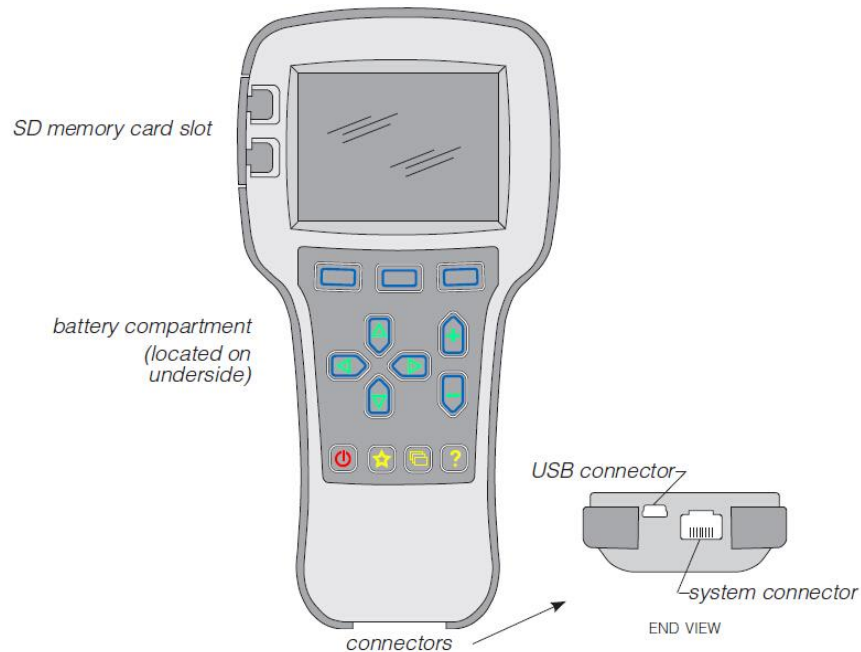

System connector

Use this connector with the supplied cable to connect the programmer to the motor controller.

USB connector

Use this connector with a USB cable to connect the programmer to a PC.

Batteries

A compartment on the underside of the unit holds two AA batteries. Power is supplied to the programmer by the controller. The battery programmer keep its real-time clock running.

SD card

SD cards provide additional memory, and are a convenient interface between a PC and the programmer.

Note that the SD card must be inserted into the programmer face down.

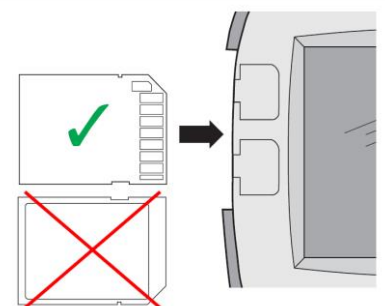

Powering up the programmer

Connect the handheld programmer into the control system by plugging it into the controller's charger/programmer port. The programmer automatically powers up, and displays this screen while it loads information from the controller.

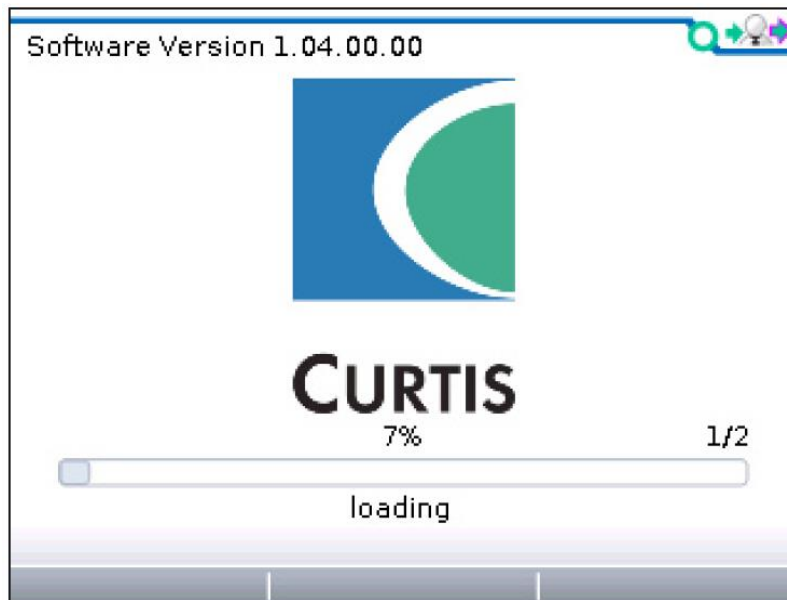

Once the programmer has uploaded the information from the controller, it displays the Main Menu.

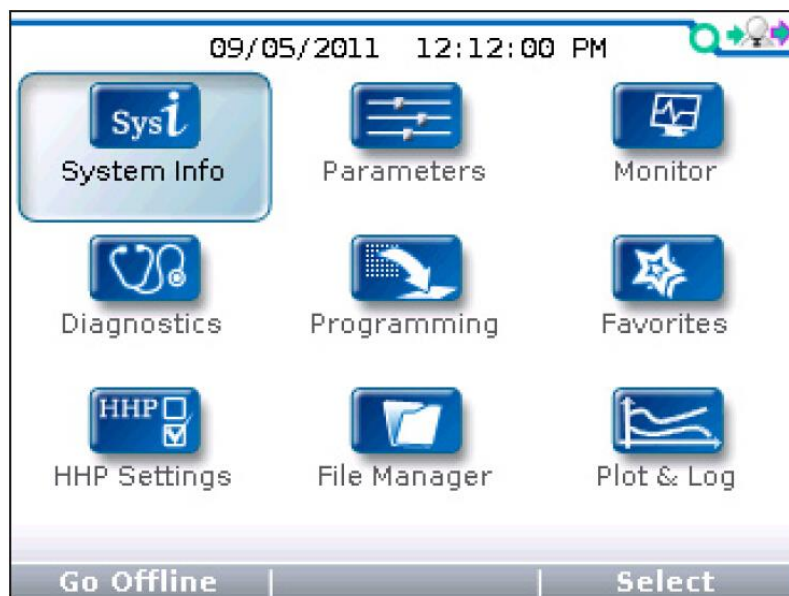

If the controller is not turned on when the programmer is connected, you can power up the programmer by pressing the Power key; the message "No System detected" will be displayed.

Display format

The high-resolution clarity of the LCD screen allows a wealth of information to be displayed at once.

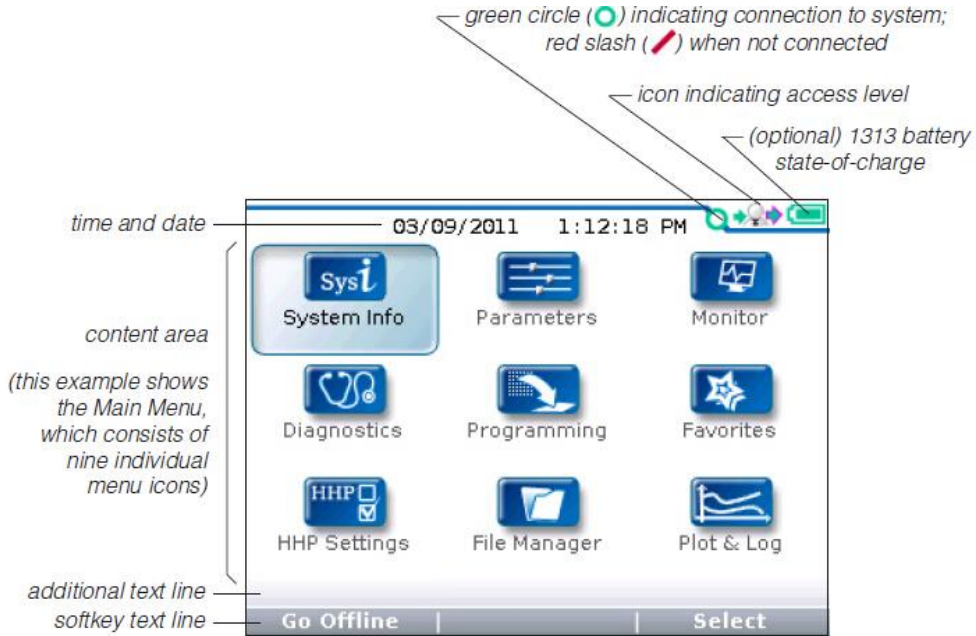

To perform an action suggested in the softkey text, press the blank softkey located directly below it.



In this example, pressing the “Select” softkey will open the System Info menu, which is highlighted. The “Select” softkey opens whichever menu is highlighted. Pressing the “Offline” softkey allows you to use the programmer when it is not connected to a controller; see Section 15.

Access level

The handheld programmer is available in four access levels: OEM, Dealer, Service, and User. Each programmer can access data at its own level and the levels below it.



Key functions

The pushbutton keys on the programmer's keypad allow you to navigate easily through the menus.

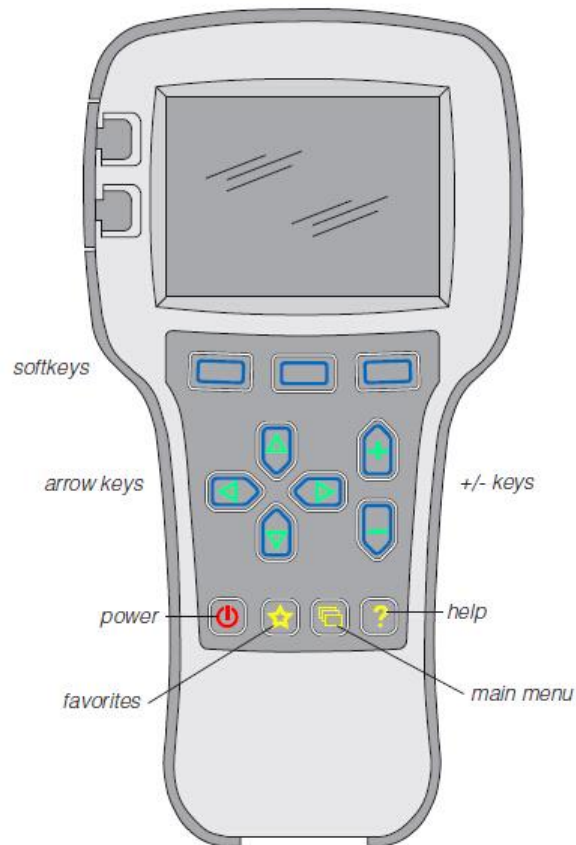

Softkeys

These three keys are blank, because their function is context-specific. At any given time, their function is shown directly above them on the LCD screen.

The symbol “»” indicates more options; pressing the softkey under the “»” will scroll to another set of options.

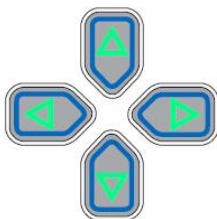

Arrow keys

With these four keys you can scroll up and down, and right and left, within the display. In the Main Menu, you can use the arrow keys to highlight one of the menus; you then open the highlighted menu using the “Select” softkey.

Within menus (other than the Main Menu), the left-arrow key is used to navigate backwards.

Within menus (other than the Main Menu), the right-arrow key is used to navigate forwards—that is, to open highlighted submenus or items.



+/- keys

These two keys allow you to increase or decrease the value of parameter settings.



They also are used as “+ = Yes” and “- = No” buttons. In some cases, they are used to scroll through several options (as in selecting an access level, or selecting a language).



Power

It is not necessary to use the Power key to turn on the programmer when you plug it into an active control system; it will turn on automatically.

To turn off the programmer, press and hold the Power key for a few seconds.

You will then be asked whether you want to power off the programmer, and the softkey text will offer you the choices “Yes” and “No.”

If you have turned off the programmer, or if it has timed out and shut itself off, pressing the Power key will turn it on again.



Favorites

This key is an alternate way to bring up the Favorites menu. You can access the Favorites menu by selecting its icon in the Main Menu, or by using the Favorites key. See the Favorites menu section for more information.



Screenshots

By pressing the Power key and then the Favorites key, you can take a screenshot of the LCD display; see Section 13.



Main Menu

This key will return you directly to the Main Menu, from wherever you are. When the Main Menu is displayed, you can also use this key to cycle through the individual menus. You can use either this key or the arrow keys to navigate within the Main Menu, whichever you prefer.



Help

This key is used to display context-specific Help texts. It is a toggle key; you can press it again to close the Help text window. You can also close Help text windows with the “Exit” softkey or by pressing the left-arrow key.

MENU ORGANIZATION

The Main Menu contains nine menus, each identified by a menu-specific icon.

Items are arranged hierarchically within menus.

Some menus may contain just one level of information, but most contain multiple levels. Items marked with a folder icon open as new submenus. Items marked with a grid icon open into tables. Items marked with a dialogue balloon icon open into a set of instructions for performing a procedure, such as calibration. At any point, you can use the left-arrow key (←) to navigate back to the previous screen. (It is possible to limit this left-arrow key function using the “Exit menu with left arrow” item in the HHP Settings menu; see Section 10.)

Menu structure

Each of the nine root menus displays the menu name in bold type at the top of the screen, beside the menu icon. As you move within a hierarchical menu, the text at the top of the screen shows the path you have taken. Note that when

This is the root level of the Parameters menu, as indicated by the bold text heading. →

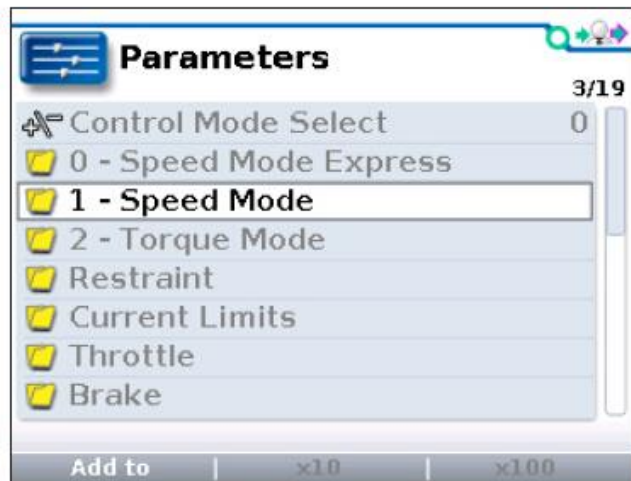

These lines of text show the path to the selected item within the Parameters menu. →

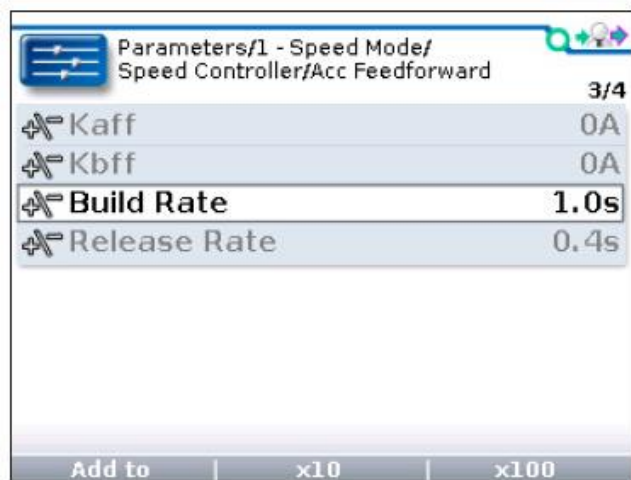
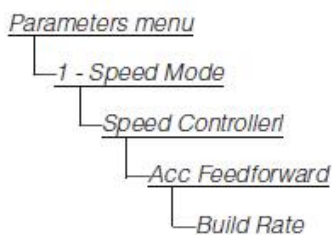

the Speed Mode folder is highlighted, the “×10” and “×100” softkeys are grayed out (indicating they do not apply)—but when Build Rate is highlighted, these softkeys are available.

When you exit a menu and then later return, the menu will open either at the place where you left it or at the root level—depending on the setting of “Remember Last View” in the HHP Settings menu. So, in this example, if “Remember Last View” is set to “On,” the next time you select the Parameters menu it will open at Build Rate (assuming you exited the menu immediately after looking at this parameter).

Types of menu items

Each item within a menu has a symbol in front of it, to indicate what type of item it is.



These are read-only items, providing detailed information; this symbol also appears on pop-up screens.



Folders indicate submenus; pressing the right-arrow key opens the folder. Often there are submenus nested within submenus. Remember, you can use the left-arrow key to navigate back out of nested menus.



These items are settings that you can adjust with the “+” and “-” keys. They may be numerical values, or yes/no choices, or even multiple choices, with the “+” and “-” keys used to cycle through the options.



These items open up a dialogue to guide you through a procedure, such as autocalibrating a throttle.



These items open up into tables. You can adjust values within the table's cells. Use the arrow keys to select cells, and the “+” and “-” keys to increase/decrease values. A text line located below the table (just above the softkey text line) shows the name of the cell and its present value.



These are read-only Monitor values.



This symbol indicates a file the programmer cannot recognize; it is also used for .hps (programmer settings) files.



These are system faults.



These are .cpf (parameter settings) files.

The nine menus

As shown on the Main Menu screen, the 1313 programmer organizes its dataset into nine menus.



The next nine sections of the manual describe these nine menus.

SYSTEM INFO MENU



In the Main Menu, highlight the System Info icon and press the “Select” softkey to go to the System Info menu. You can return to the Main Menu by pressing the Main Menu key.

The System Info menu opens directly to a detail screen providing information about the motor controller to which the programmer is connected:

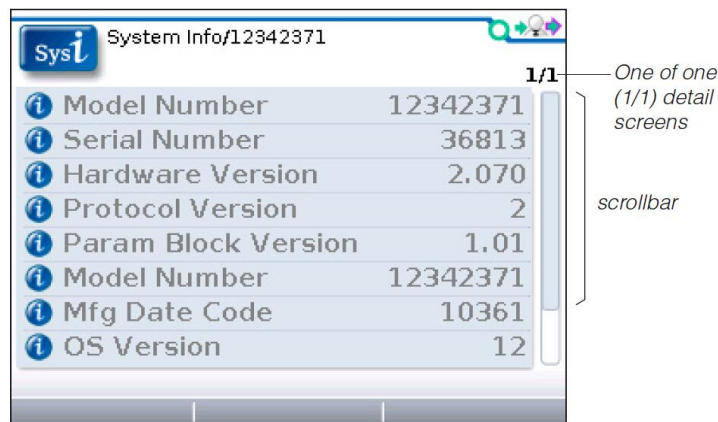

The sliding bar at the right of the screen indicates there are more items than those shown. Use the down-arrow key to scroll down to see the rest of the list.



PARAMETERS MENU



In the Main Menu, highlight the Parameters icon and press the “Select” softkey to go to the Parameters menu. You can return to the Main Menu at any time by pressing the Main Menu key ().

The Parameters menu is likely to be the menu you use most often. This is where you can adjust the settings of the control system’s adjustable parameters.

You navigate through this complex menu using the arrow keys, +/- keys, and softkeys, as described in Section 2.

The parameters shown depend on the controller model and on the access level of your handheld programmer.

The Help function provides concise information about each parameter.

To access the Help function, press the Help key (?). Refer to your controller manual for additional information about the various parameters.

With some “+|-” parameters, the item can be expanded to show a bar graph indicating where the setting lies within the available range.

Here is a parameter called Forward Max, as it first appears:

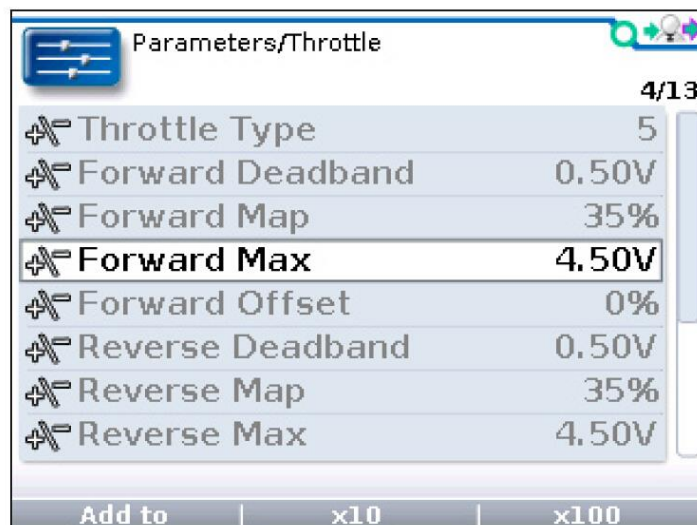

And here it is expanded, by pressing the right-arrow key

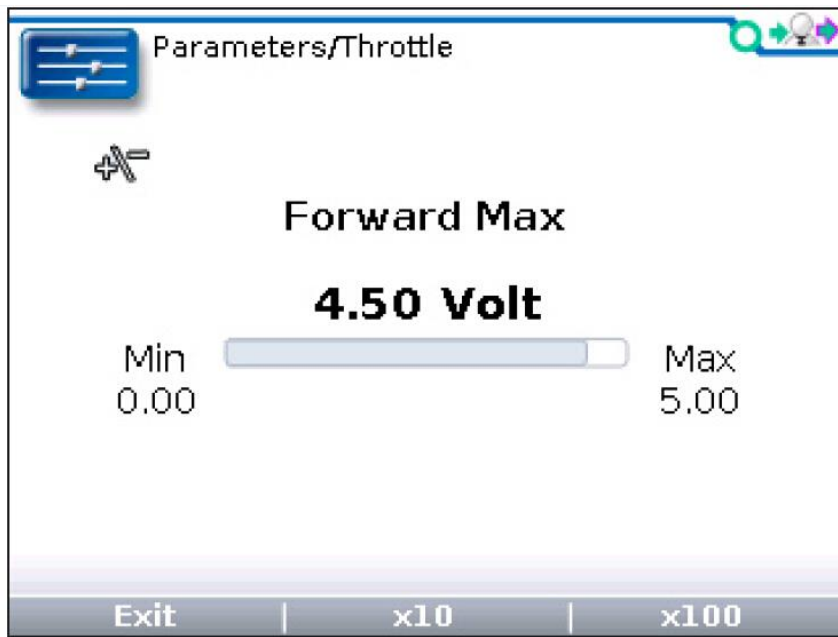

Note that the “+\-” symbol is repeated on this screen, to remind you of the type of item this is.

Softkeys available in Parameters menu



“Add to” is available for each adjustable parameter. This softkey takes you to a screen where you choose where to add the parameter: you can add it to your Favorites collection, or you can place it in the Plot or Log programs.

The “×10” or “×100” softkey, when pressed together with the “+” or “-” key, allows you to change values rapidly—in increments of ten or a hundred times the parameter’s step-size. For example, the Forward Max parameter shown above has a range of 0.00 to 5.00 volts, in 0.01V increments. With the “×10” softkey you can change the setting from 4.50 to 4.40 in one jump instead of ten, or with the “×100” softkey you can change the setting from 4.50 to 3.50 in one jump instead of a hundred jumps. For parameters with narrow ranges (for example, a parameter that can be set to 1 through 5), the “×” softkeys allow you to jump to the extreme high or low end of the range in one step.



The “Exit” option appears on expanded items, such as the Forward Max bargraph shown above. The “×10” and “×100” softkeys are still available when you are looking at the expanded item. The “Exit” option also appears when a Help screen is displayed.

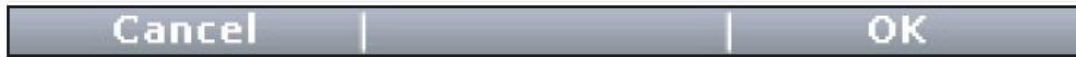

The “OK” and “Cancel” options appear on the screens guiding you through procedures, such as calibrating a throttle, or whenever changing a value will put the system into idle mode.

Be aware that as you change parameter settings, the new values replace the earlier values. If you make adjustments that you don’ t like, and wish you could return to the earlier values, you cannot do this—unless you have written down those earlier settings (which is unlikely) or unless you have saved them. To save your parameter settings, use the “Save.cpf File” function in the Programming menu; see Section 8. Your parameter settings will then be saved in a.cpf file.

You can save as many.cpf files as you desire, and you can create unique names for them. If you prefer, each.cpf can automatically be given a name consisting of the date and time when it was created; see the “Text for save as” item in the HHP menu (Section 10).

For information on creating names, see Section 13: Using the Keyboard.

MONITOR MENU



In the Main Menu, highlight the Monitor icon and press the “Select” softkey to go to the Monitor menu. You can return to the Main Menu at any time by pressing the Main Menu key.

The Monitor menu provides real-time data from the control system, especially useful in testing and troubleshooting.

You can press the Help key (?) for a brief description of any monitored value, if you are unclear about what is being measured. Refer to your controller’s technical manual for additional information about the various monitored variables.

As in the Parameters menu, you can highlight an item and use the rightarrow key () to see an expanded item screen, typically a bar graph indicating where the present value of that item lies within its range.

Softkeys available in Monitor menu

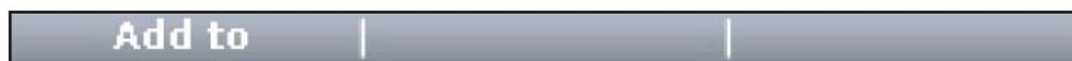

“Add to” is available for each monitored item. This softkey takes you to a screen where you choose where to add the item: you can add it to your Favorites collection, or you can place it in the Plot or Log programs.



The “Exit” option appears on expanded item screens. This option is also available when a Help screen is displayed. Alternatively, you can use the left-arrow key to exit these screens.

DIAGNOSTICS MENU



In the Main Menu, highlight the Diagnostics icon and press the “Select” softkey to go to the Diagnostics menu. You can return to the Main Menu at any time by pressing the Main Menu key.

The Diagnostics menu contains two folders: Present Errors and Fault History.

Note: Sometimes the fault circuits catch a temporary event that is not a true fault in the system; it is always a good idea to turn the control system off and back on again to see whether the fault clears by itself.

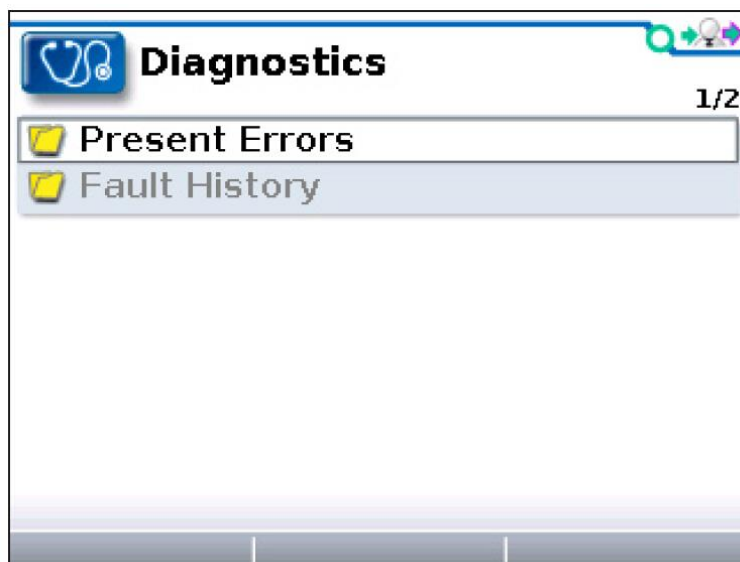

Present Errors folder

All existing faults are listed here, in chronological order. An item in this folder can only be removed by remedying the fault. As long as the fault exists, it will be included in the Present Errors folder. The “1/3” in the upper right corner of the screen indicates that Missing Contactor is the first of three present faults.

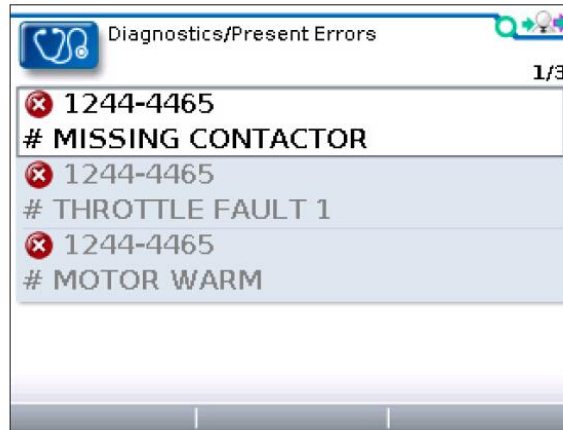

Fault History folder

This folder lists all the faults encountered since the Fault History was last cleared. You can clear the entire contents of this folder to allow a fresh Fault History to be started.

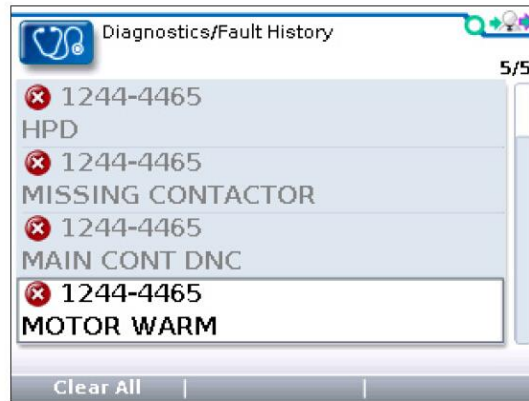

Softkey available in Diagnostics menu

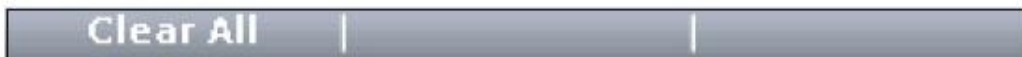

“Clear All” is used to empty the Fault History folder. This softkey appears only when the Fault History folder (or one of the faults within that folder) is highlighted.

1232SE AC CONTROLLER PROGRAMMING

APPENDIX 1:

The programming data sheet for Curtis

1232SE AC controller for 4kw/5.5kw AC motor.



ONLY PROFESSIONAL PERSON ARE ALLOWED TO CONDUCT THE ADJUSTING OR REPAIRS ON CONTROLLER . ANYONE WHO HAS NO EXPERIENCE ON ELECTRONIC COMPONENTS MAINTENANCE ARE NOT ALLOWED TO OPERATE ON THE CONTROLLER . UNREQUIED OPERATIONS ON THE CONTROLLER MAY CAUSE PERNAMENT DAMGES TO CONTROLLER

DO NOT OPEN UP THE CONTROLLER . ANY ATTEMPTIONS TRY TO REPAIR DEFECT CONTROLLER SHOULD UNDER THE GUIDANCE OF DEALER OR MANUFACTURER'S TECHNICIAN .

Plug in the handheld programmer for troubleshooting codes display. Use the Controller troubleshooting chart for reference to find out the faulty parts.



Check wiring harness connections



Following the malfunction elimination instructions .



Use the component testing instructions as reference test and fix the problems

HOW TO TROUBLESHOOT ELECTRIC SYSTEM

Controller diagnostics

Diagnostics information can be obtained in either of two ways: (1) by reading the display on a 1313 handheld or (2) by observing the fault codes issued by the Status LEDs. See Table below for a summary of LED display formats.

The 1313 programmer will display all faults that are currently set as well as a history of the faults that have been set since the history log was last cleared. The programmer displays the faults by name.

The pair of LEDs built into the controller (one red, one yellow) produce flash codes displaying all the currently set faults in a repeating cycle. Each code consists of two digits. The red LED flashes once to indicate that the first digit of the code will follow; the yellow LED then flashes the appropriate number of times for the first digit. The red LED flashes twice to indicate that the second digit of the code will follow; the yellow LED flashes the appropriate number of times for the second digit.

Status LED Window



TYPES OF LED DISPLAY

DISPLAY	STATUS
Neither LED illuminated	Controller is not powered on; or vehicle has dead battery; or severe damage.
Yellow LED flashing	Controller is operating normally.
Yellow and red LEDs both on solid	Controller is in Flash program mode.
Red LED on solid	No software loaded, or an internal hardware fault detected by the Supervisor or Primary microprocessor. Cycle KSI to clear. Reload software or replace controller if necessary.
Red LED and yellow LED flashing alternately	Controller has detected a fault. 2-digit code flashed by yellow LED identifies the specific fault; one or two flashes by red LED indicate whether first or second code digit will follow.

HOW TO TROUBLESHOOT ELECTRIC SYSTEM

Controller troubleshooting

The troubleshooting chart, Table 6, provides the following information on all the controller faults:

- fault code
- fault name as displayed on the programmer's LCD
- the effect of the fault
- possible causes of the fault
- fault set conditions
- fault clear conditions.

Whenever a fault is encountered and no wiring or vehicle fault can be found, shut off KSI and turn it back on to see if the fault clears. If it does not, shut off KSI and remove the 35-pin connector. Check the connector for corrosion or damage, clean it if necessary, and re-insert it.

APPENDIX 2:

The troubleshooting chart for 1232SE AC controller.

I .ELECTRONIC SYSTEM

1. vehicle velocity dropping (AC System)

Problem: Voltmeter indicate the battery is still at least half full but the vehicle runs very slow both with "HIGH" and "LOW" mode .

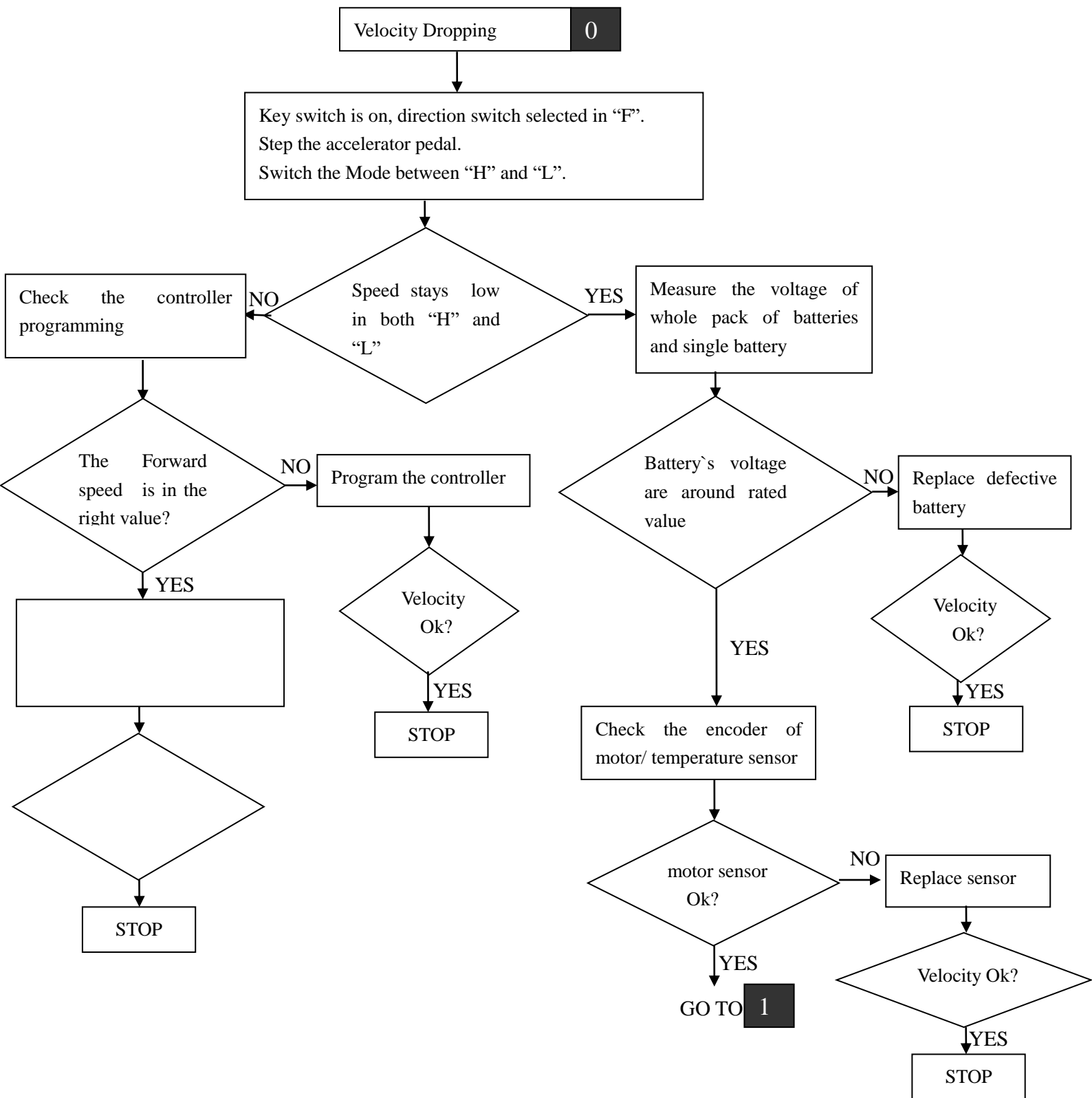

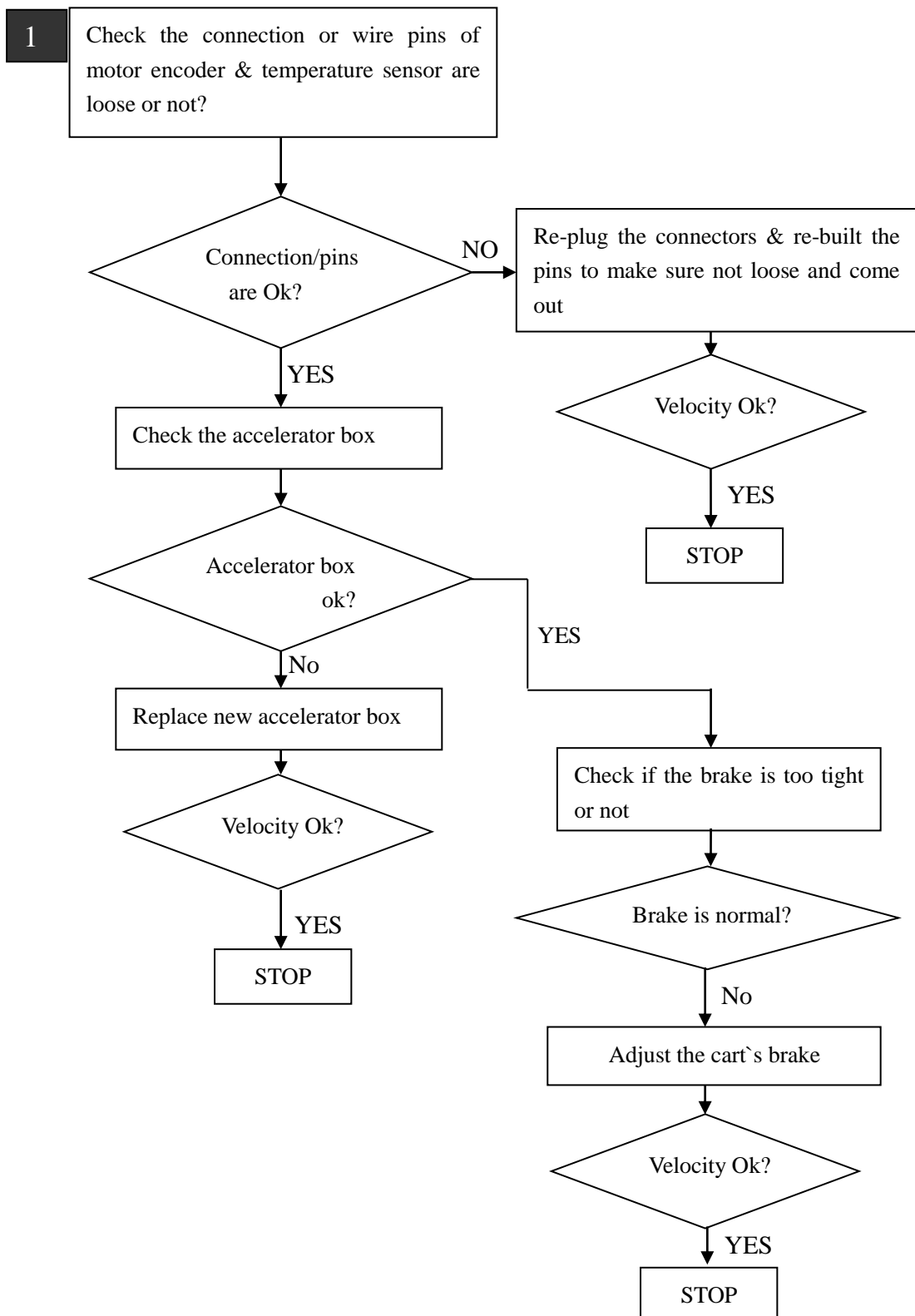

If vehicle has severe velocity drop .The battery unit should be checked. The totally voltage should be bigger than 48V (if 48V system). Otherwise every single battery should be checked . The voltage should be bigger than rated voltage . If not then the battery unit should be recharged or replaced .

The Encoder and temperature Sensor Fault will also cause severe velocity drop . Meanwhile the accelerator box ,especially potentiometer should be checked .

Following the troubleshooting tree will give you the right guiding of the inspections .

2. vehicle does not run (AC System)

Refer the main component testing section as defective components testing instructions .

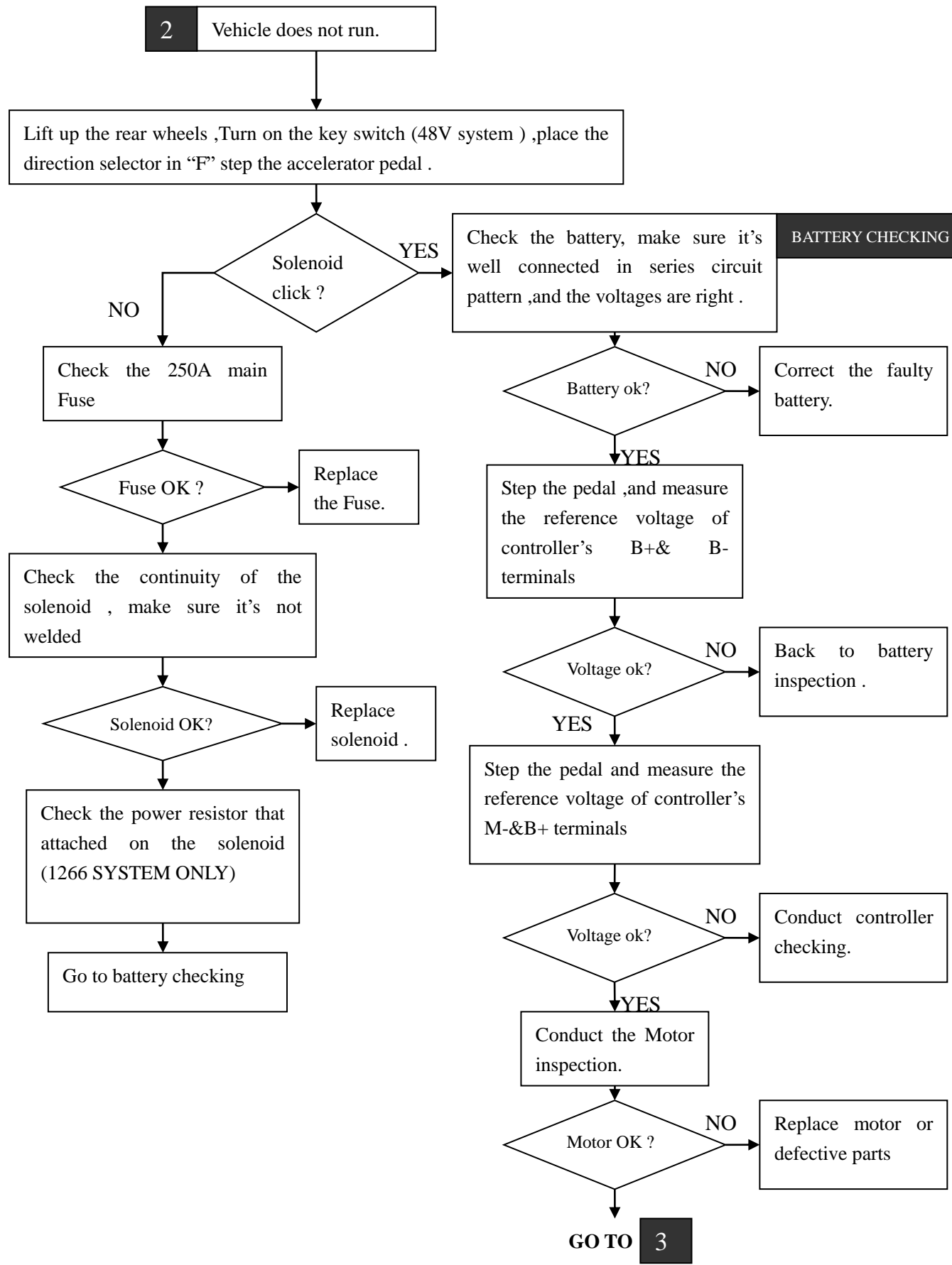

Refer the main component testing section as defective components testing instructions .

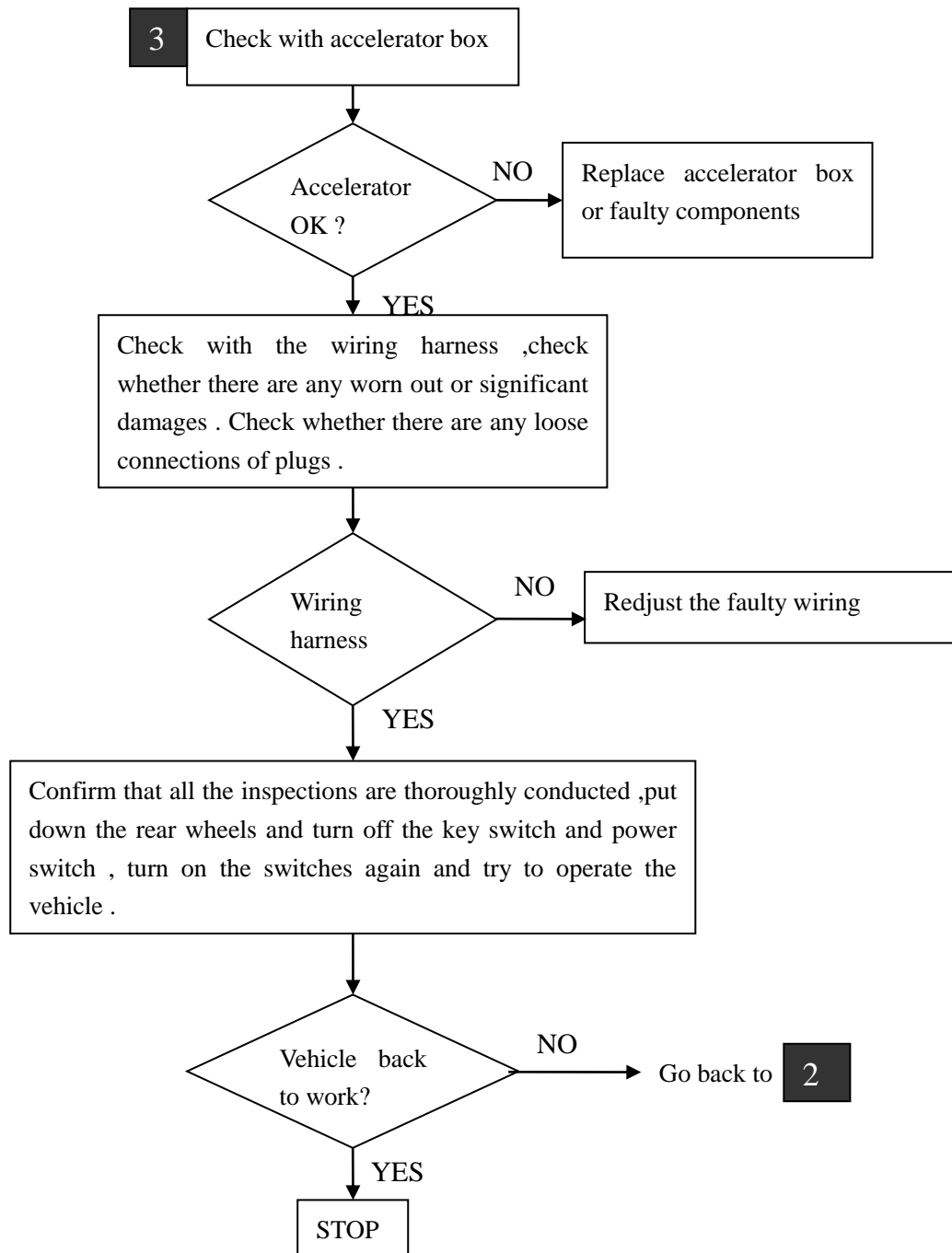

3. Vehicle jerks while on run

Problem :Vehicle jerks suddenly while driving the vehicle ,sometimes may have severe velocity dropping or can not move suddenly.

Note : The vehicle jerks basically caused by loose connection of the wirings or faulty batteries .The current of the main circuitry surges while the accelerator be stepped deeper ,but if certain parts of the wirings become loose then it won't be able to take the big current , it will have sudden break up ,and that's why the vehicle jerks while on run .

Refer the main component testing section as defective components testing instructions .

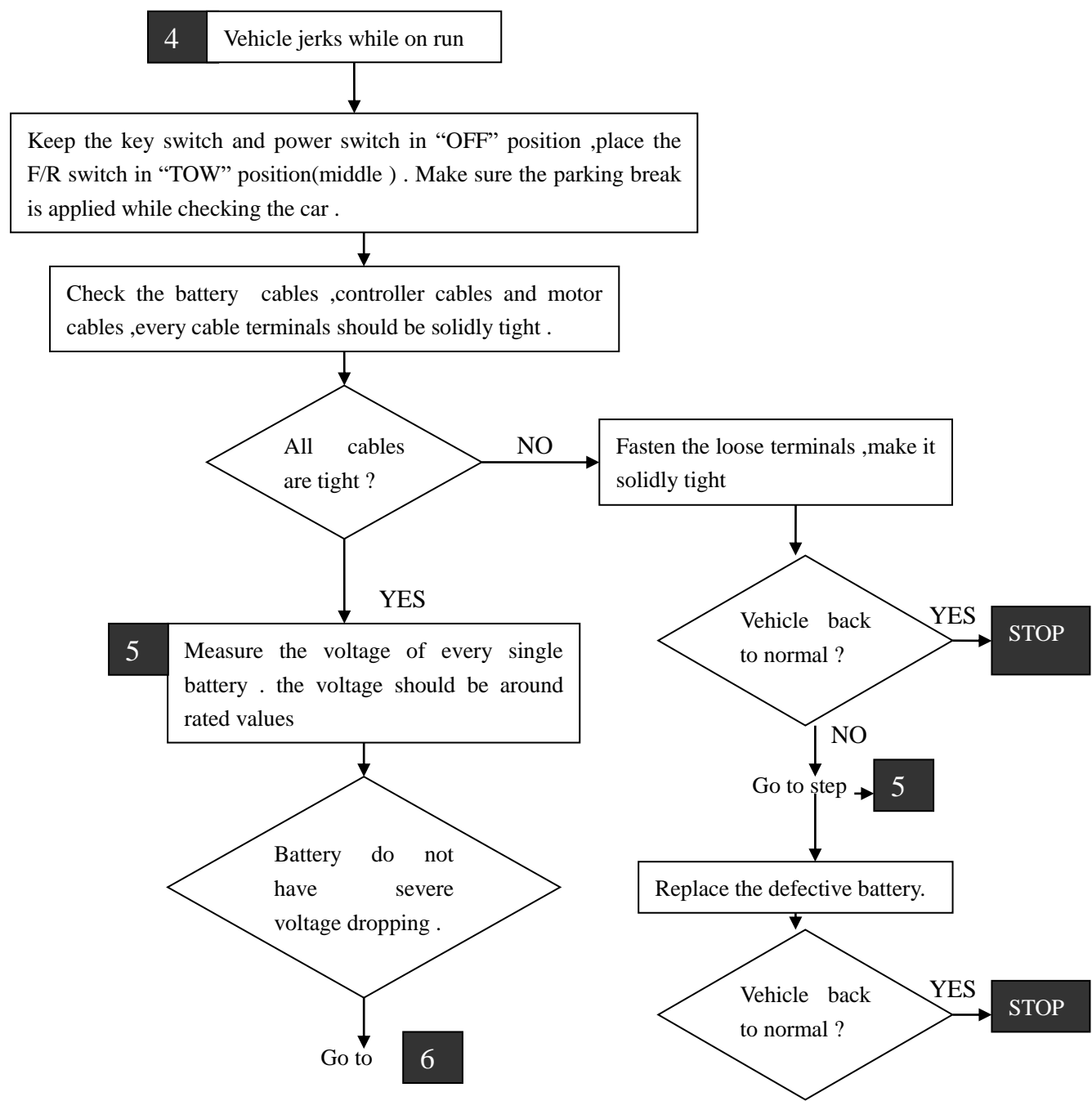

Refer the main component testing section as defective components testing instructions .

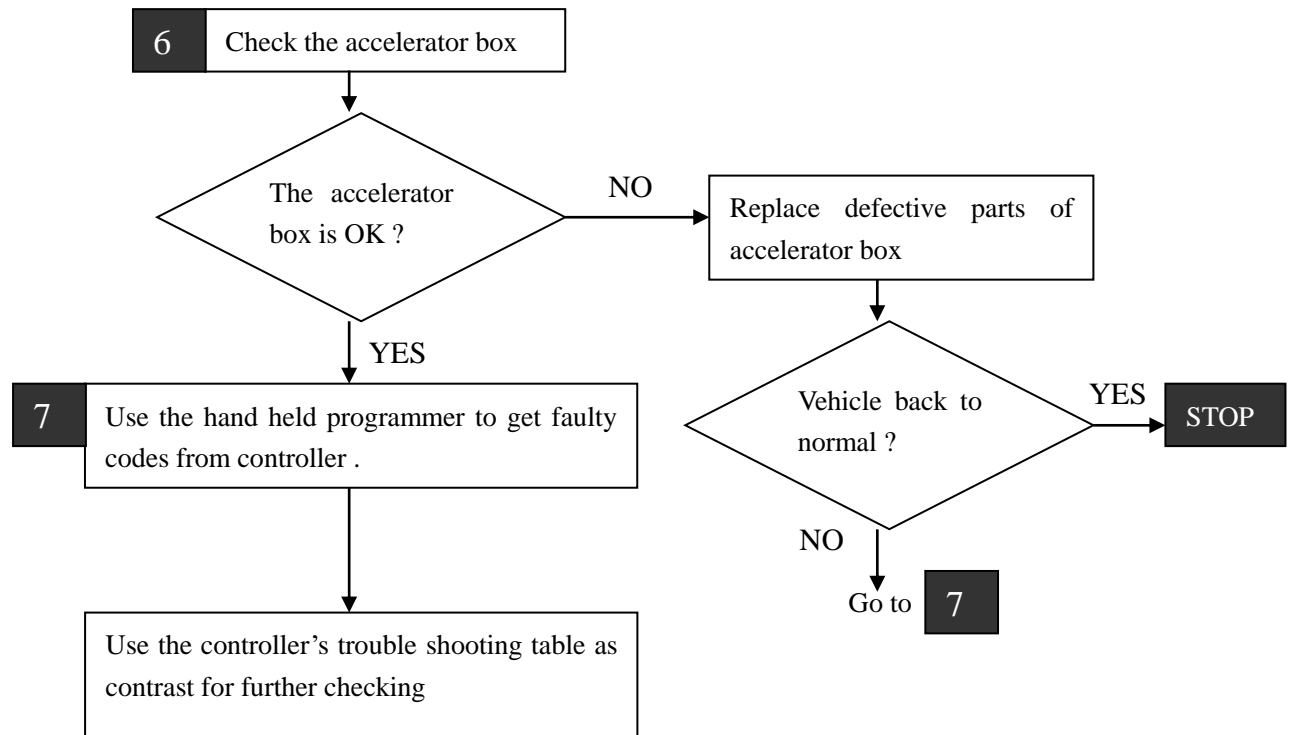

4. Vehicle has inconsistent power output

Problem : Vehicle does not have smooth power output during acceleration or cruising . The power output feels like on and off .
Note: Wrong controller programming \Bad battery unit \inconsistent potentiometer output will most possibly cause the problem .

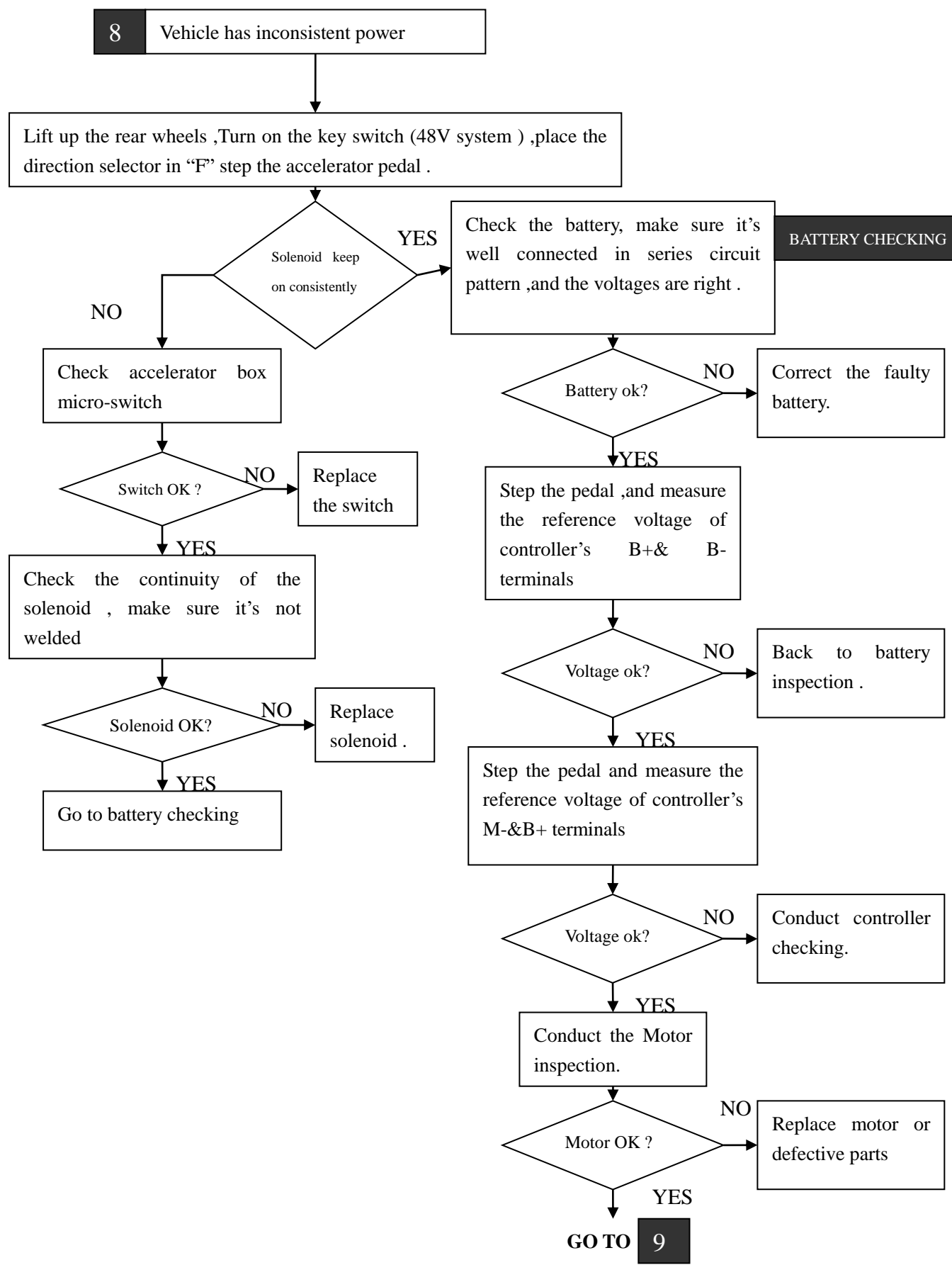

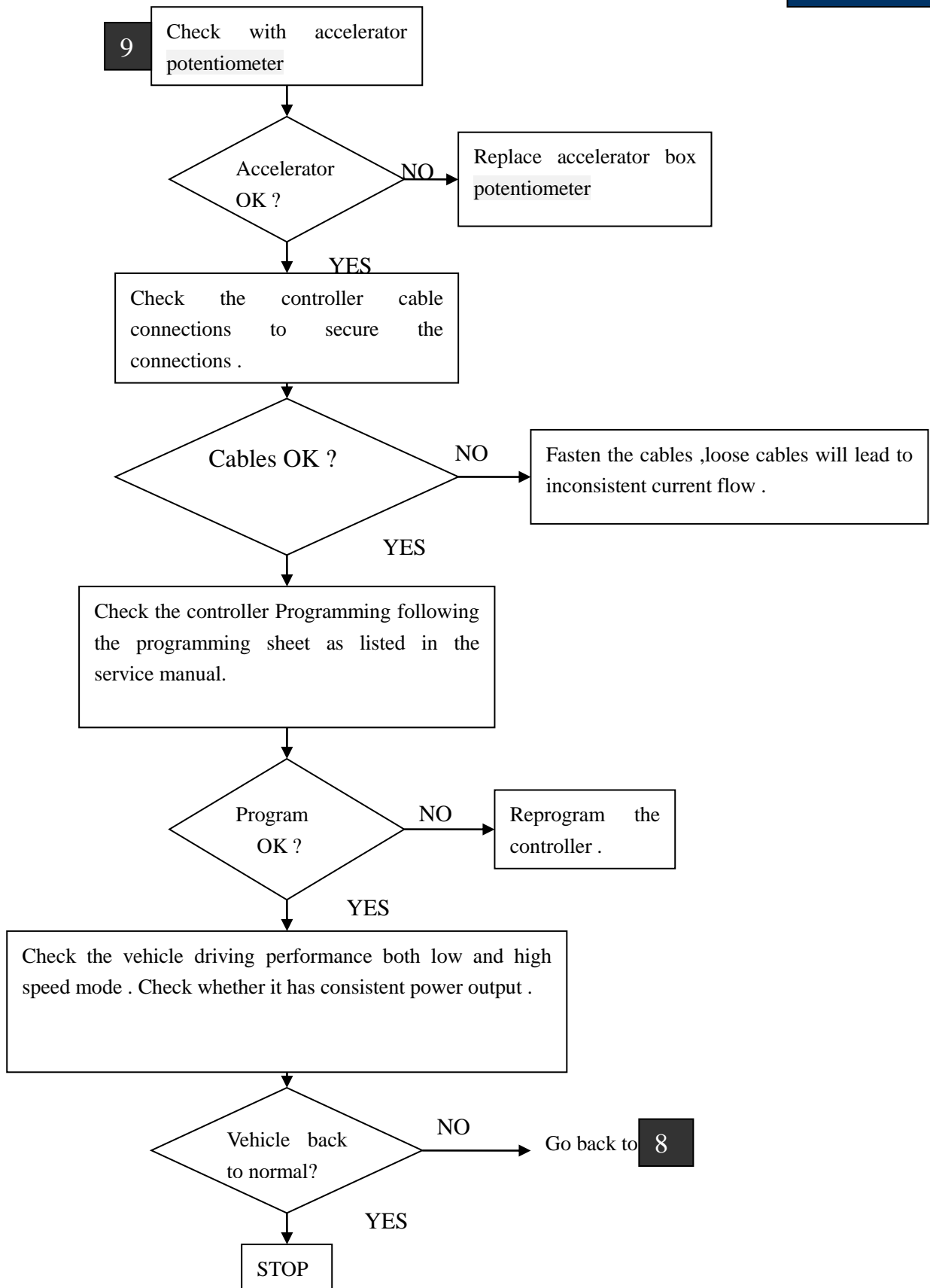

5. Vehicle has inconsistent power output in high speed traveling

Refer the main component testing section as defective components testing instructions .

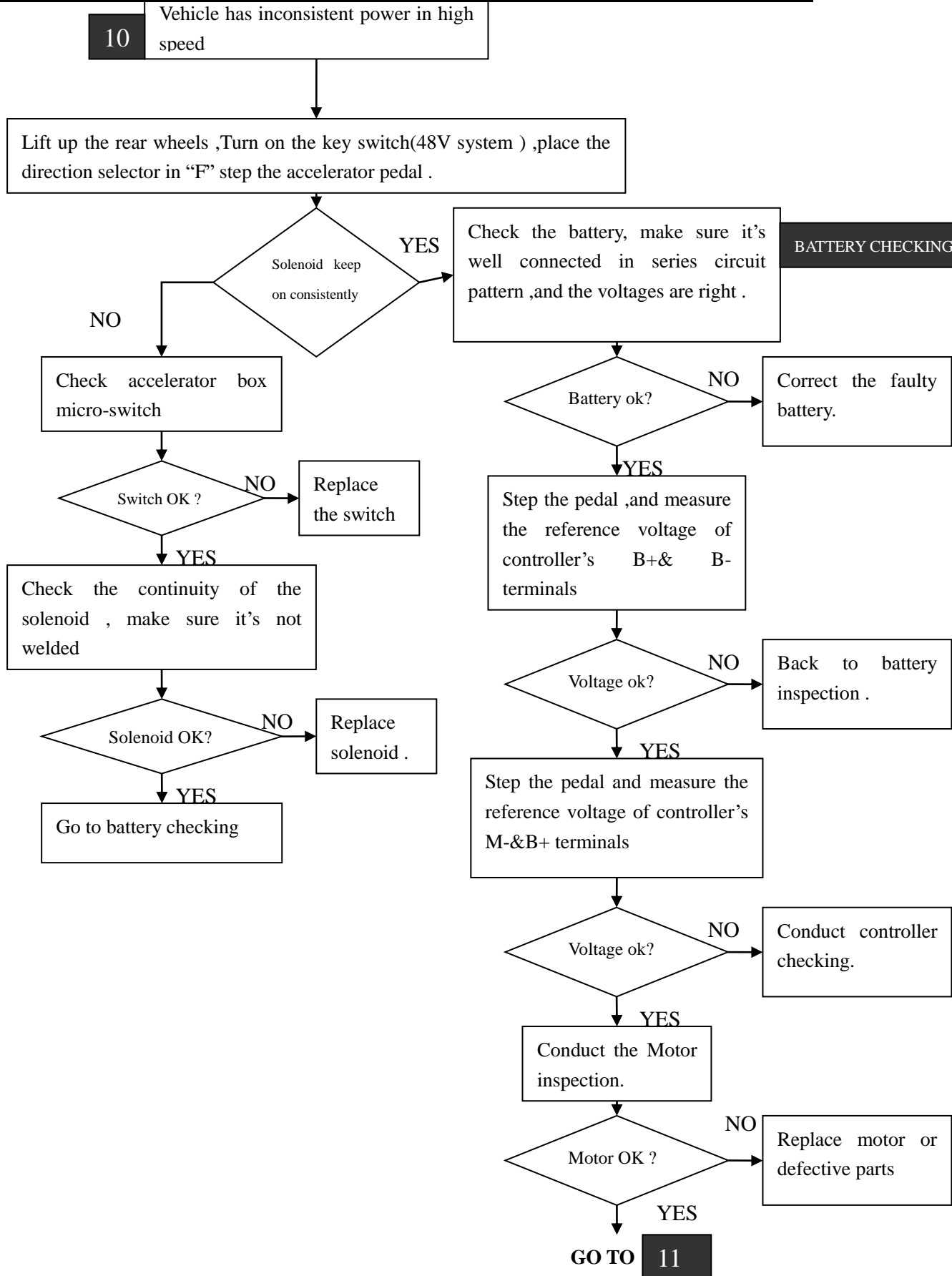

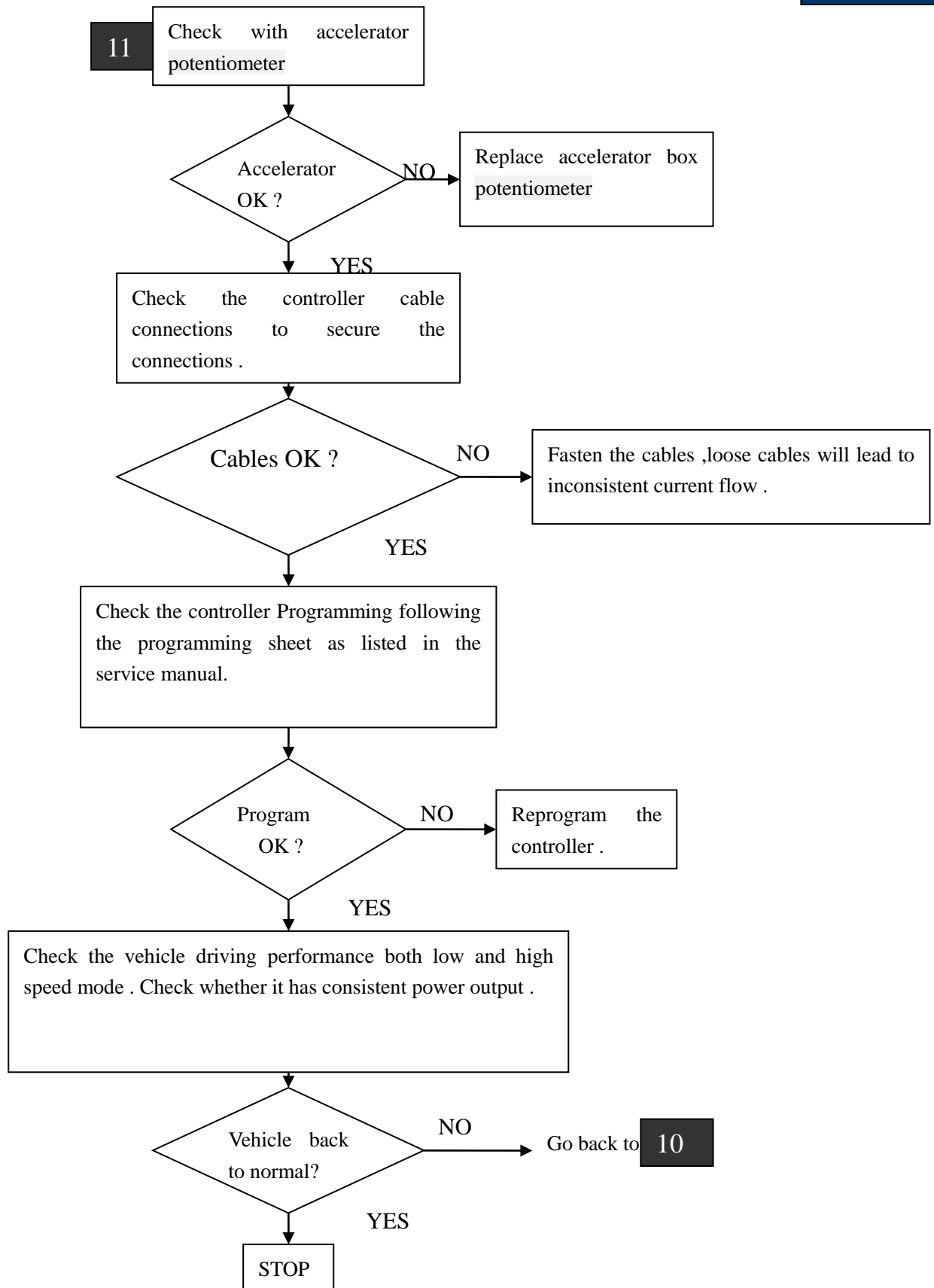

6. Vehicle stops when blow the horn or turn on other devices

Refer the main component testing section as defective components testing instructions .

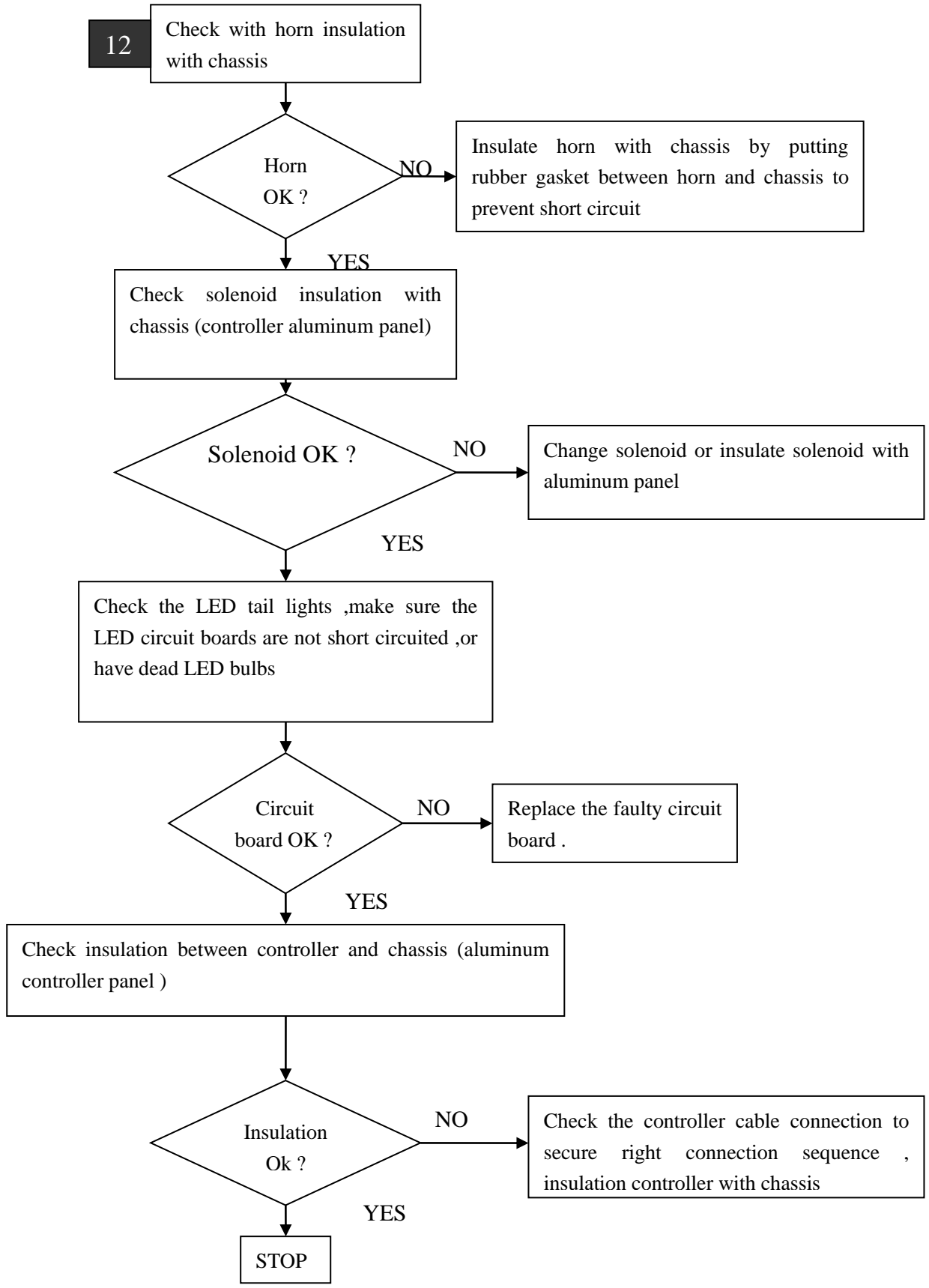

7. Vehicle stops but goes after shake or push the vehicle

Refer the main component testing section as defective components testing instructions .

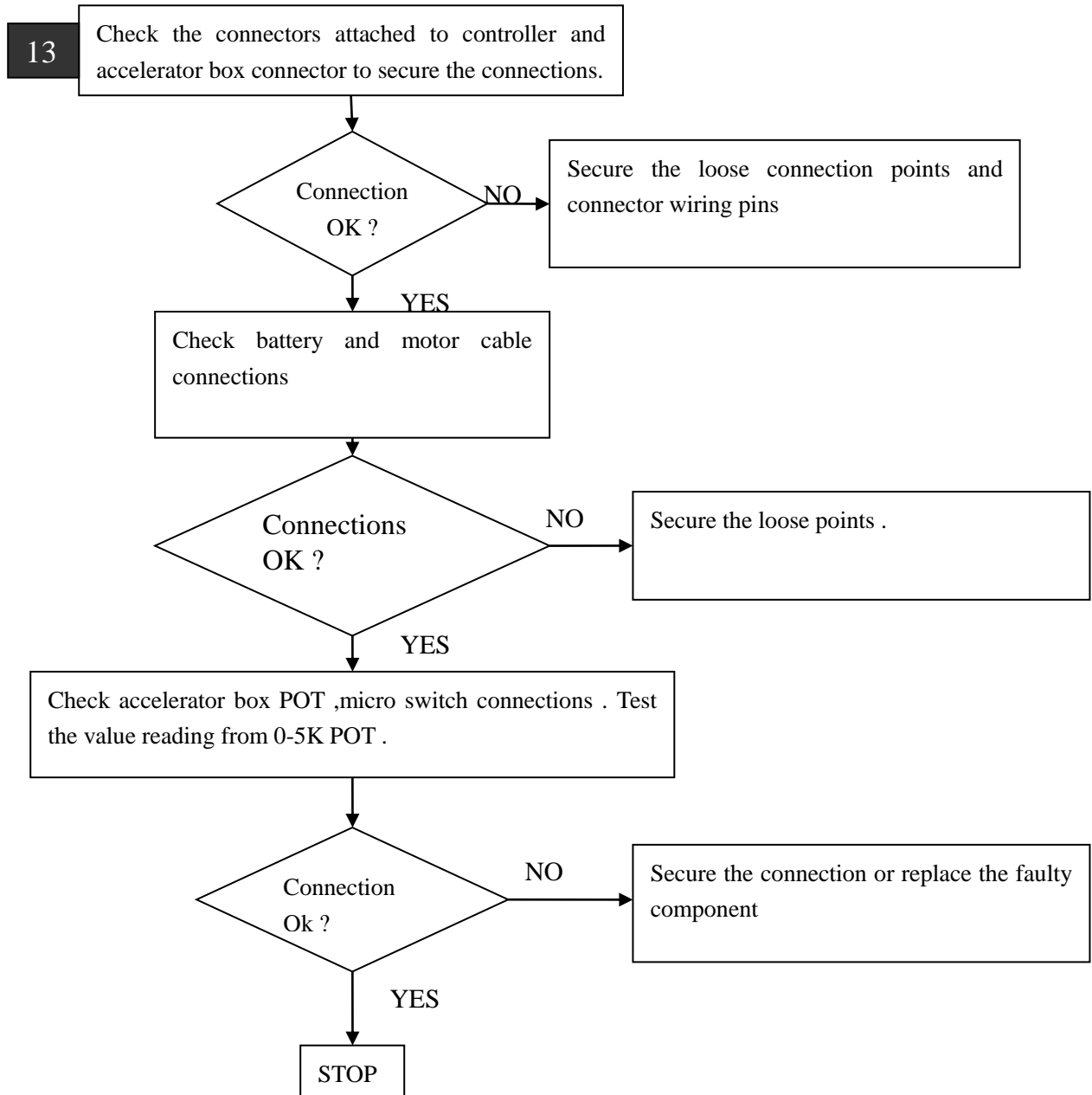

8. speedometer can not work

Refer the main component testing section as defective components testing instructions .

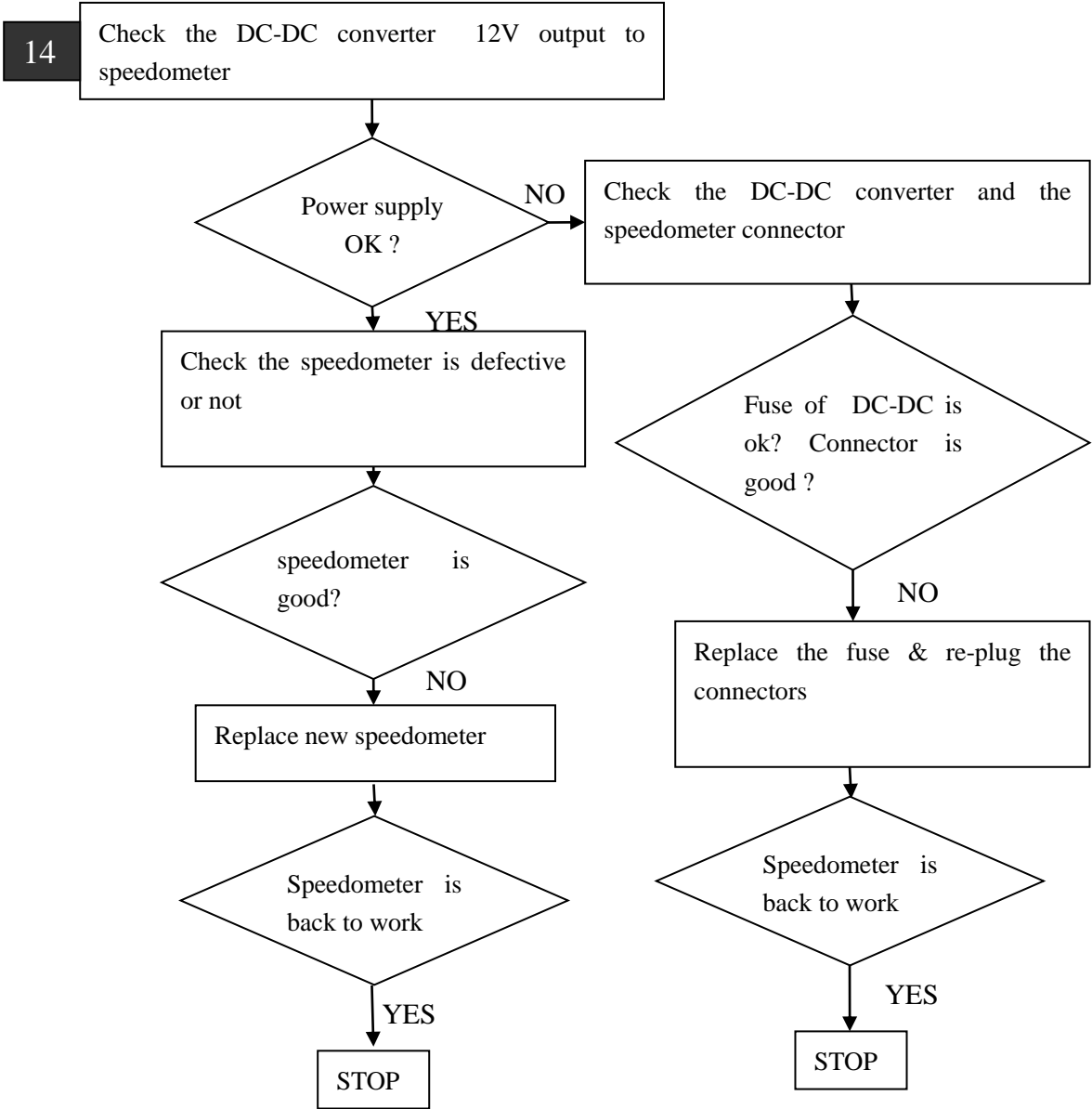

9. Motor has a big sound in running

Refer the main component testing section as defective components testing instructions .

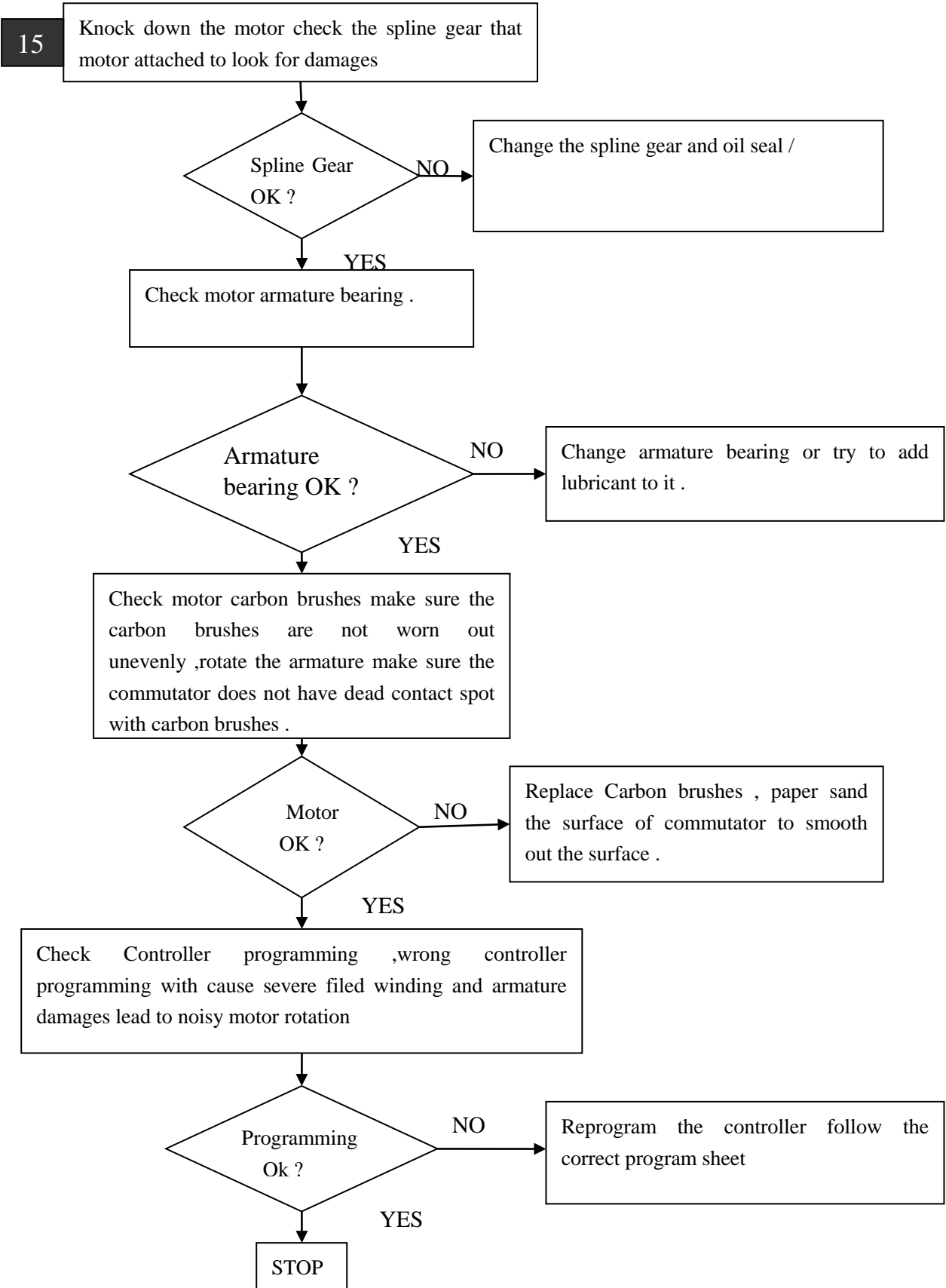

10. Motor burnt down

① Overload of cart . If the cart is overloaded and keep running for long time then the motor will most certainly heated up ..

② The motor is not big enough to conquer the terrain . The motor if it's 48v 5.3KW but it keep heating up ,means that this motor is probably too small for use . We can either change the motor to a bigger one or change the parameters of controller to promote the performance . From enclosure you will find the way about how to change to change the parameter to make the motor more powerful .

Refer the main component testing section as defective components testing instructions .

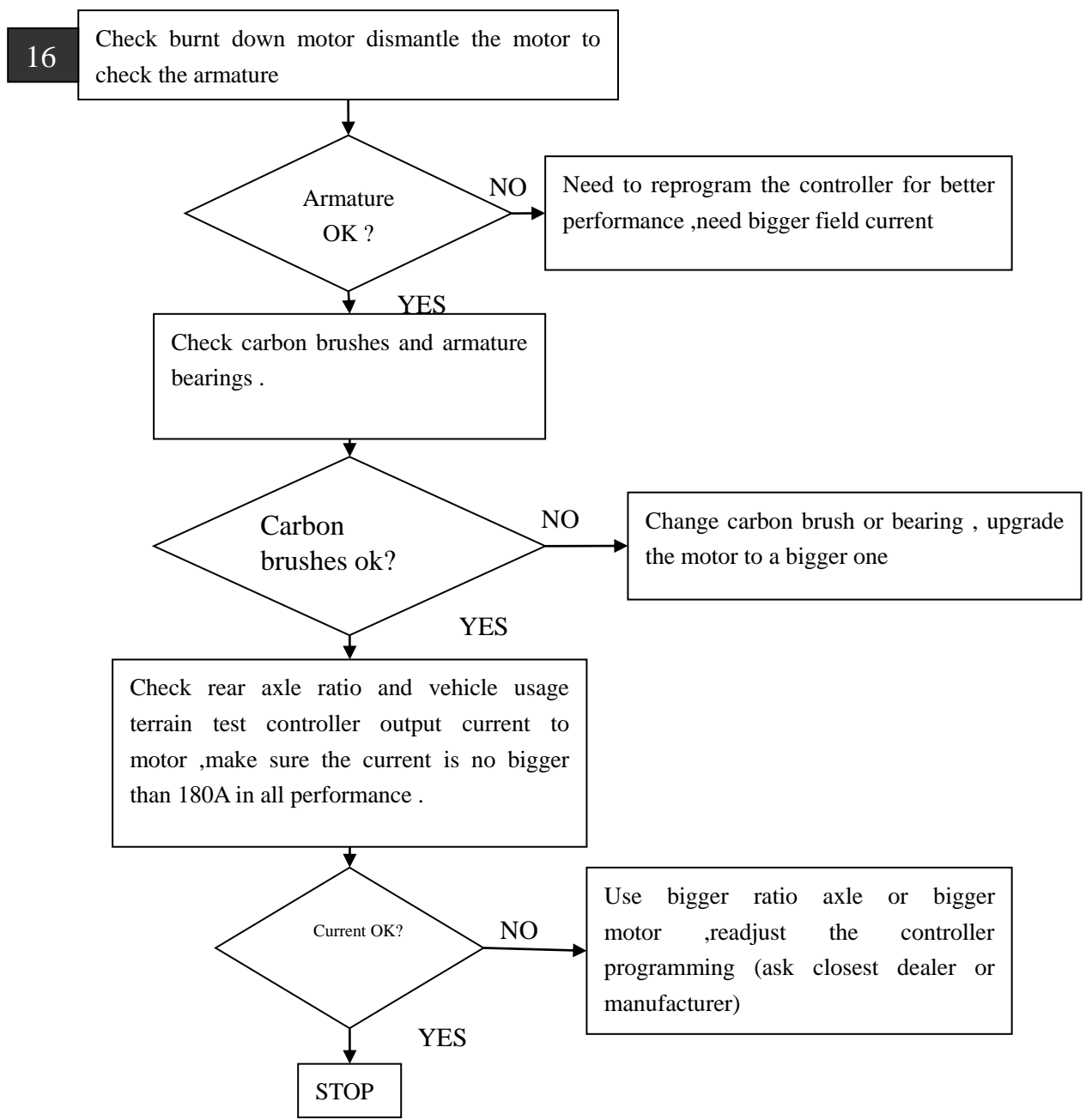

11.Vehicle lose range severely

Vehicle lose range severely mostly caused by bad battery pack ,wrong vehicle system configuration ,degraded motor or faulty mechanical transmission(struck brake or faulty rear axle)

Refer the main component testing section as defective components testing instructions .

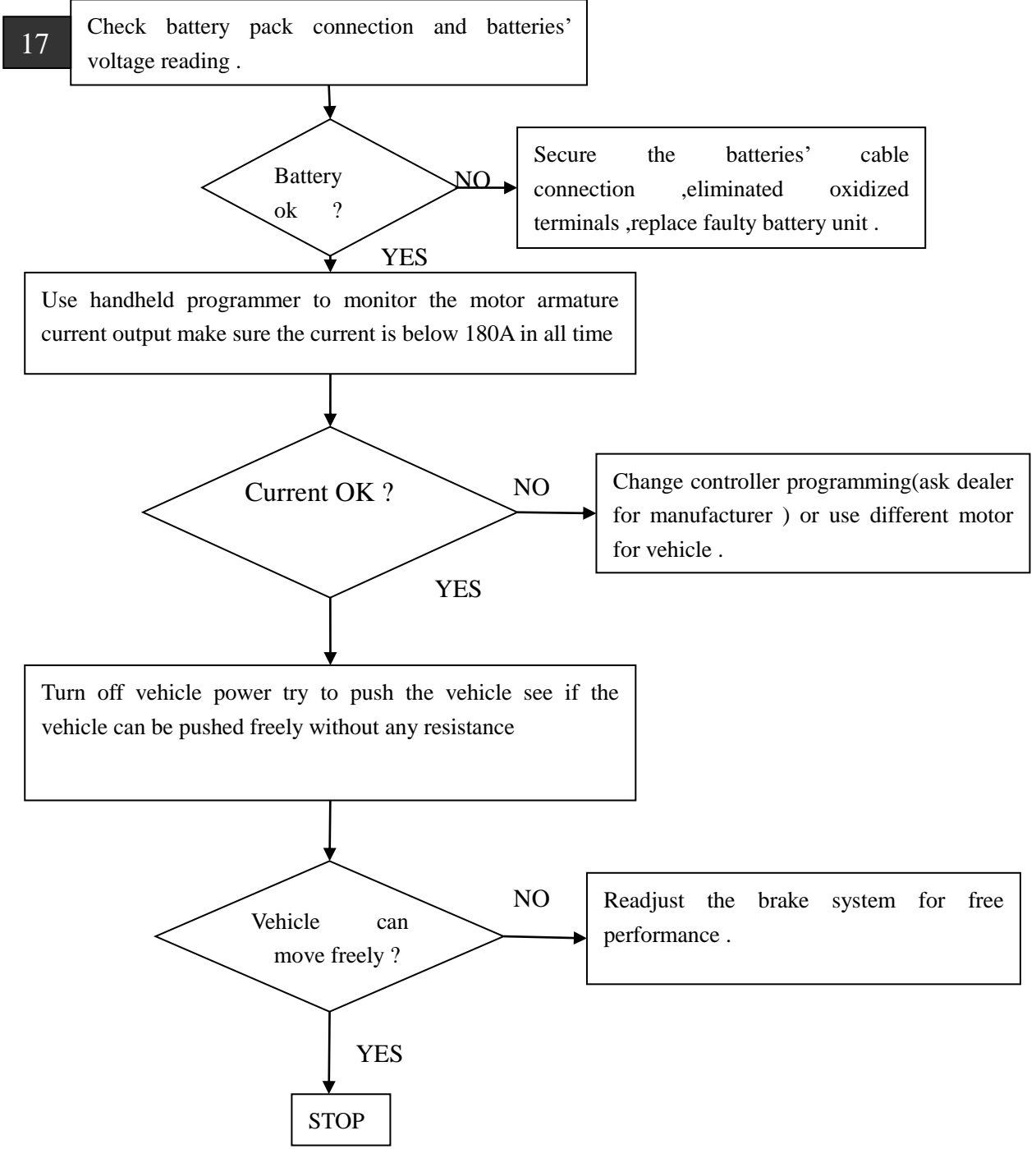

12. Solenoid works intermittently

Vehicle solenoid works intermittently causing sudden stops or failure to operate the electric vehicle .The continuity and insulation of solenoid need to be checked .

Refer the main component testing section as defective components testing instructions .

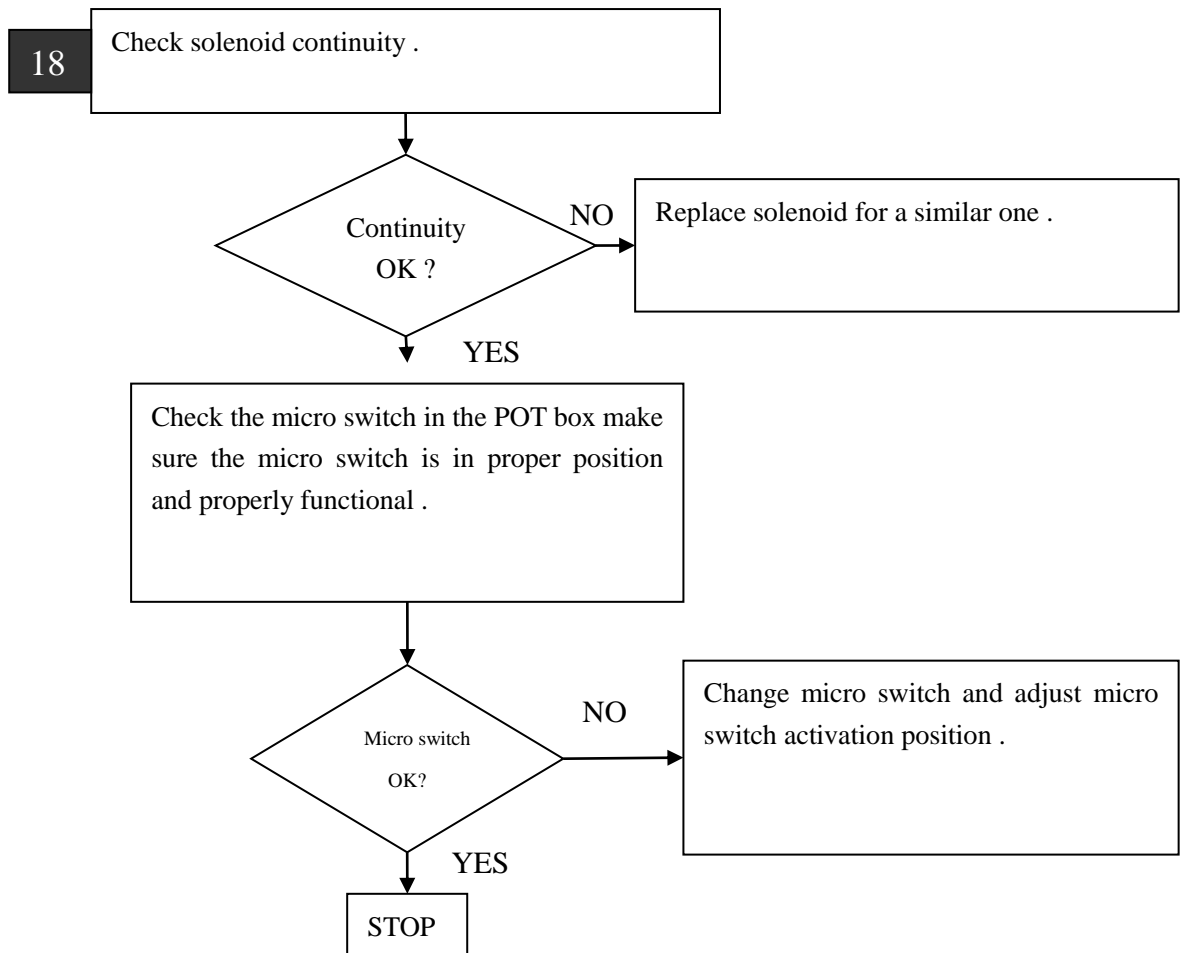

13.Charger indication LED flashing in red .

If charger status light indicate in red color both steady led or flashing red ,it means that error occurred during usage . please follow the trouble shooting chart in the charger chapter to find out the problems

Refer the main component testing section as defective components testing instructions .

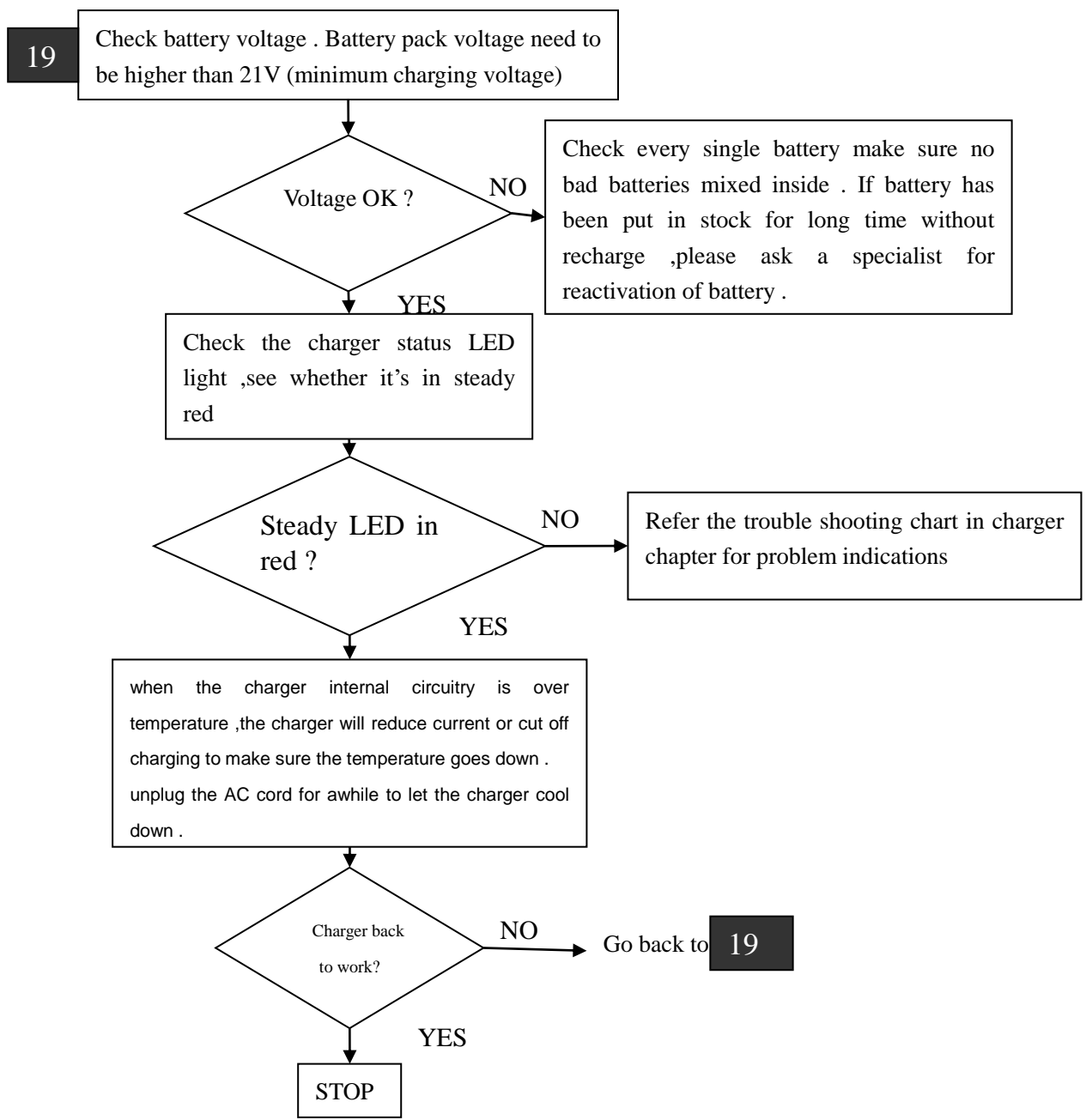

14. Charger can not charge battery

The battery pack need constant charge to keep the battery alive ,if vehicle has been put in stock for long time without recharging the battery units probably have been drained out severely need activation machine to reactivate he battery pack .Charger has fours stages of charging processing ,measure the current output of charger .

Refer the main component testing section as defective components testing instructions .

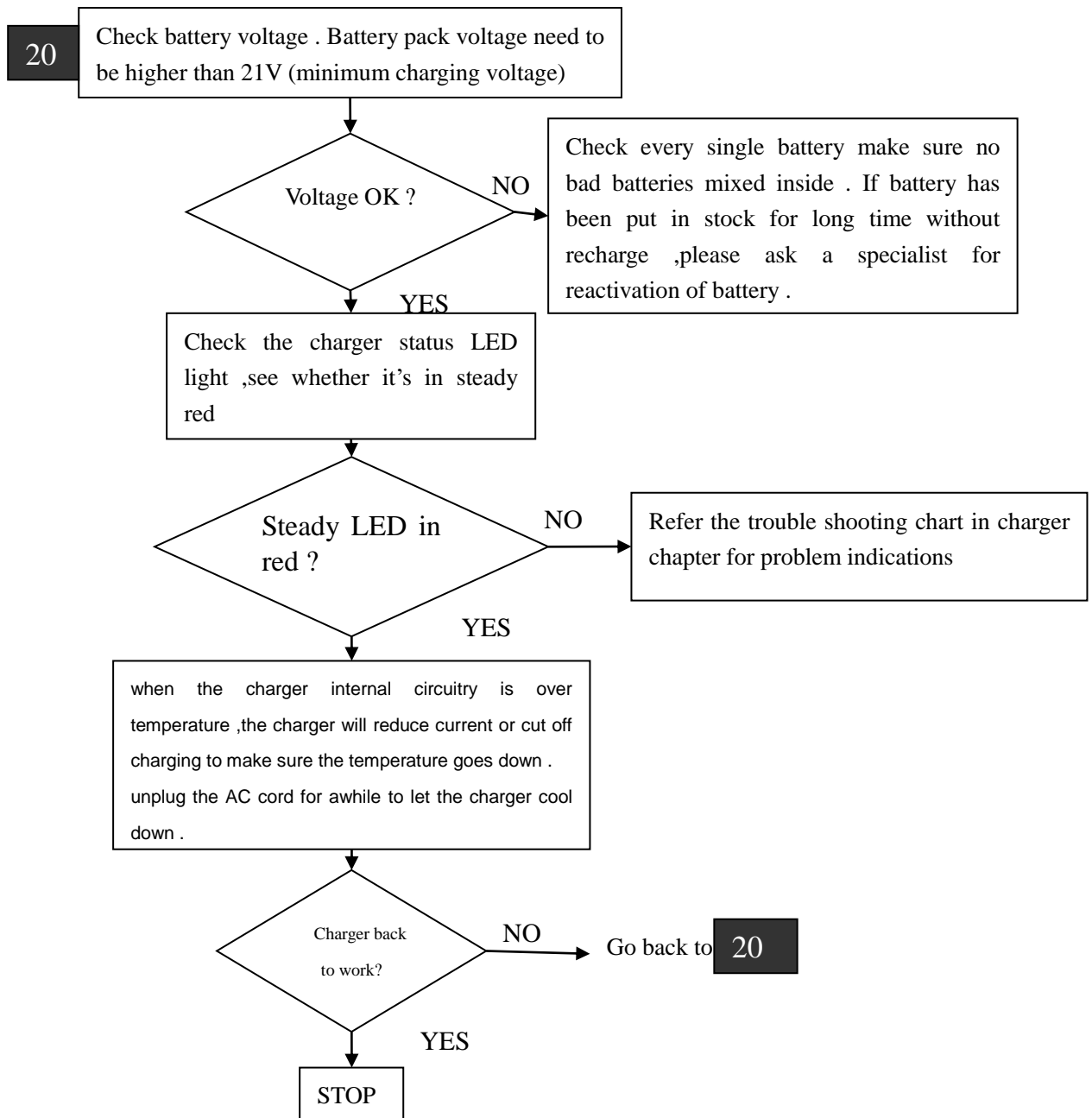

15. DC-DC converter not working

DC-DC converter functional as voltage converter to supply 12v power for all the accessories . DC-DC converter input and output connection methods are not like the conventional electric devices , please refer the diagram attached in next page .

Refer the main component testing section as defective components testing instructions .

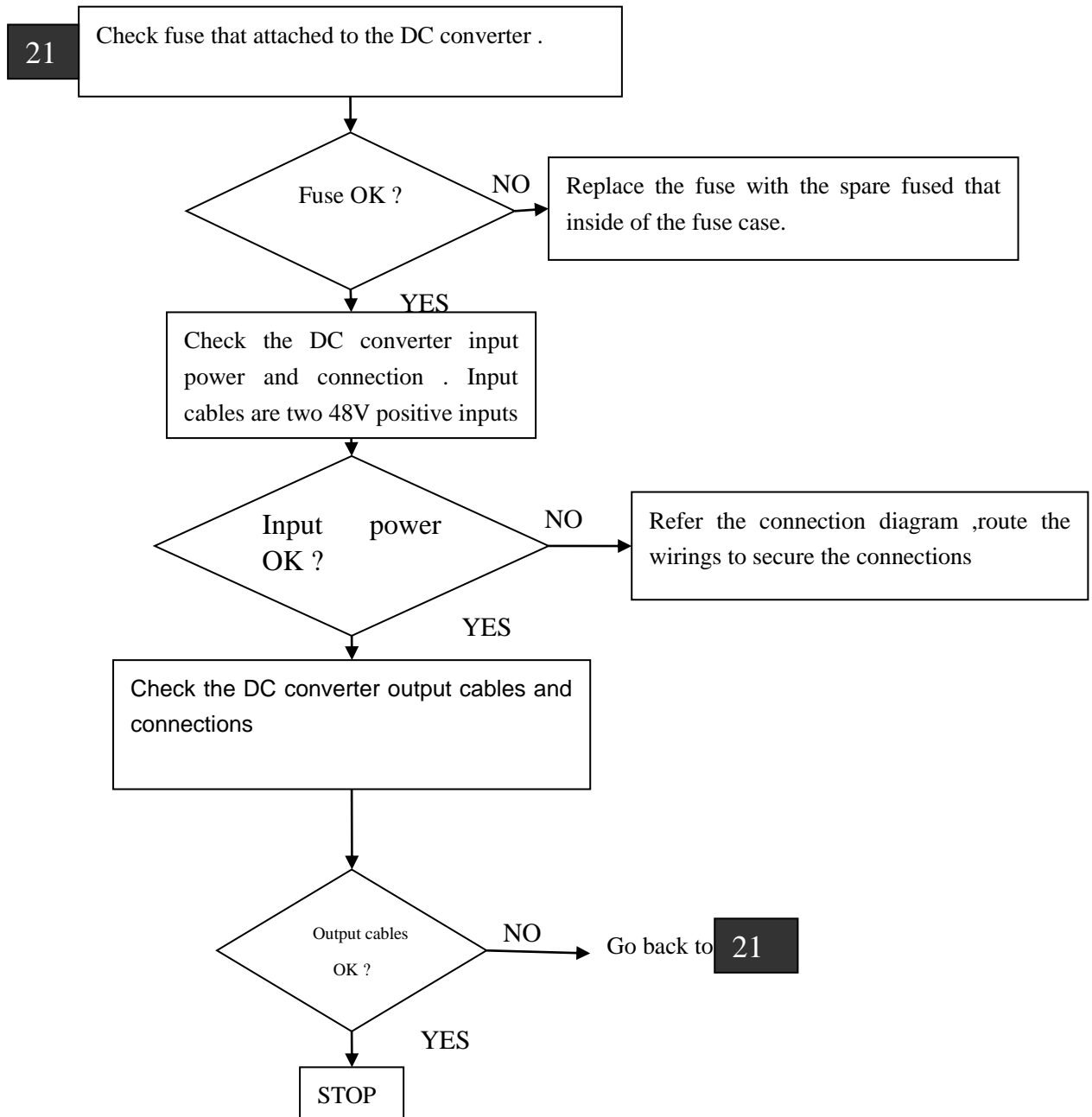

31487/31486 Voltage Converter

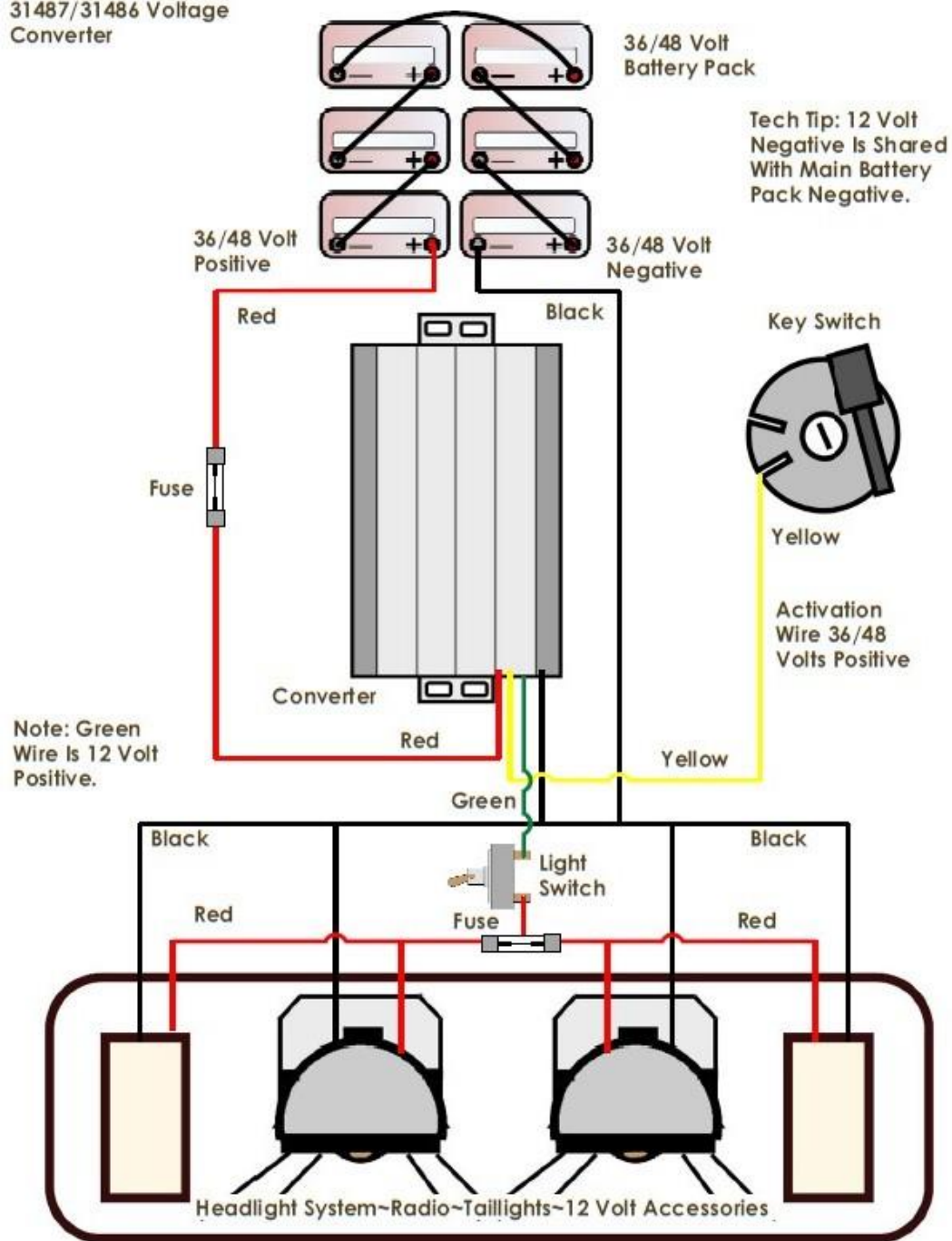

© Copyright Nivel LLC
All Rights Reserved

16. Rear LED tail light break down

Rear LED light circuit board is LED bubbles connected in series pattern then connected in parallel pattern . refer the diagram as attached below

Refer the main component testing section as defective components testing instructions .

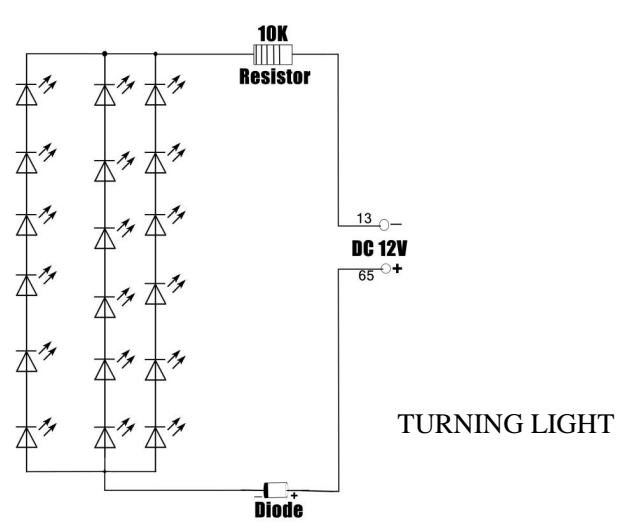
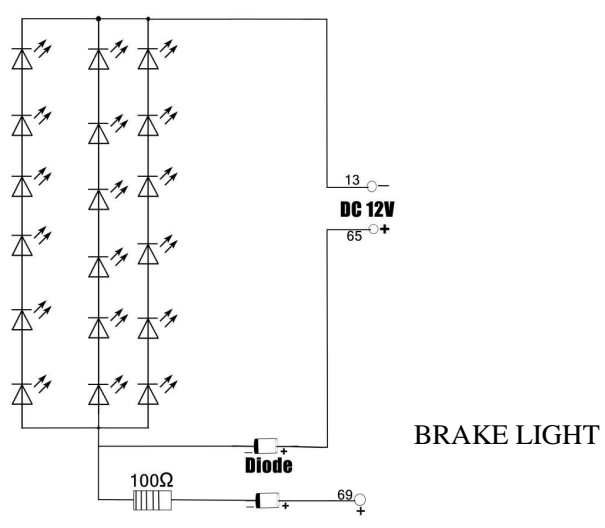
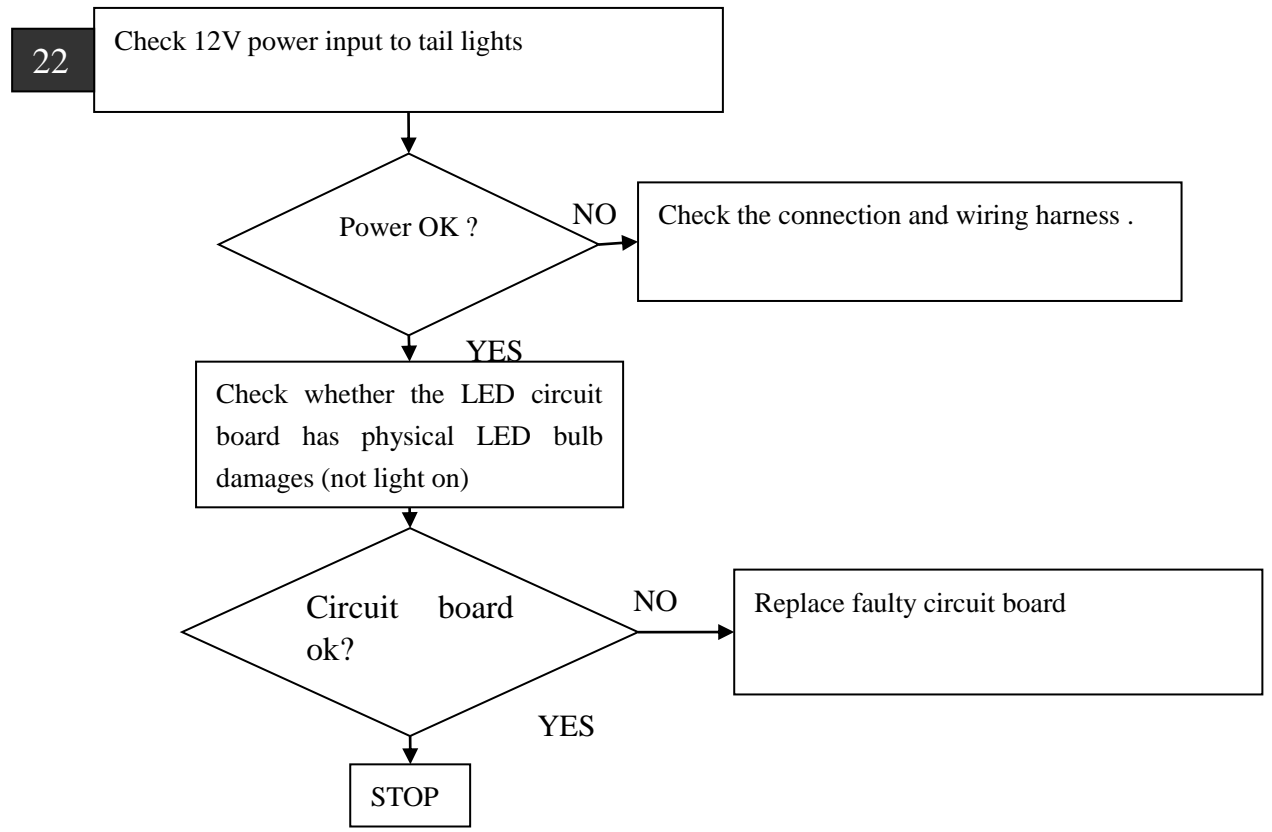

17. Front light bulb break down

Front headlight bulb break down mostly due to water contamination , short circuit unstable power input .
Water seal behind of light assembly need to secured

Refer the main component testing section as defective components testing instructions .

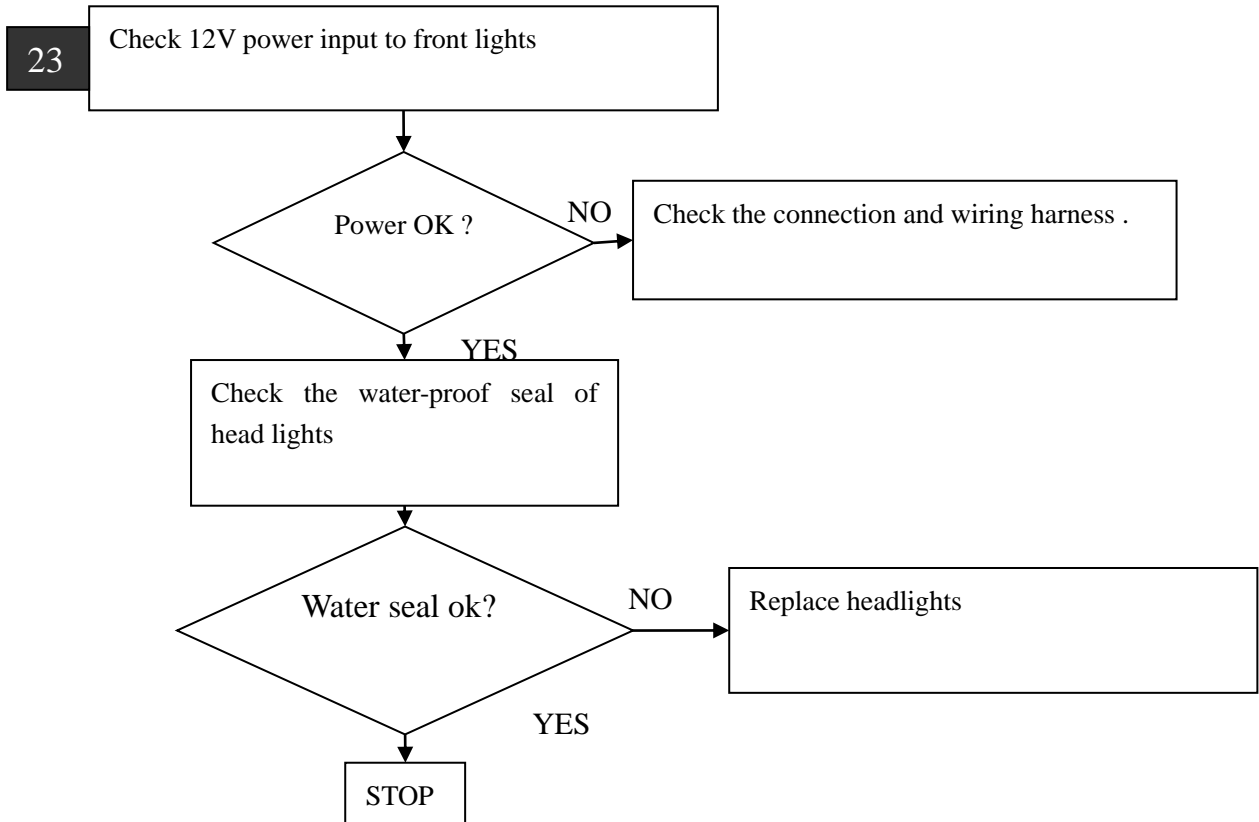

18. Switch assembly not functional

Switch assembly not functional mostly due to mechanical failure ,loose connection ,wiring damages .

Refer the main component testing section as defective components testing instructions .

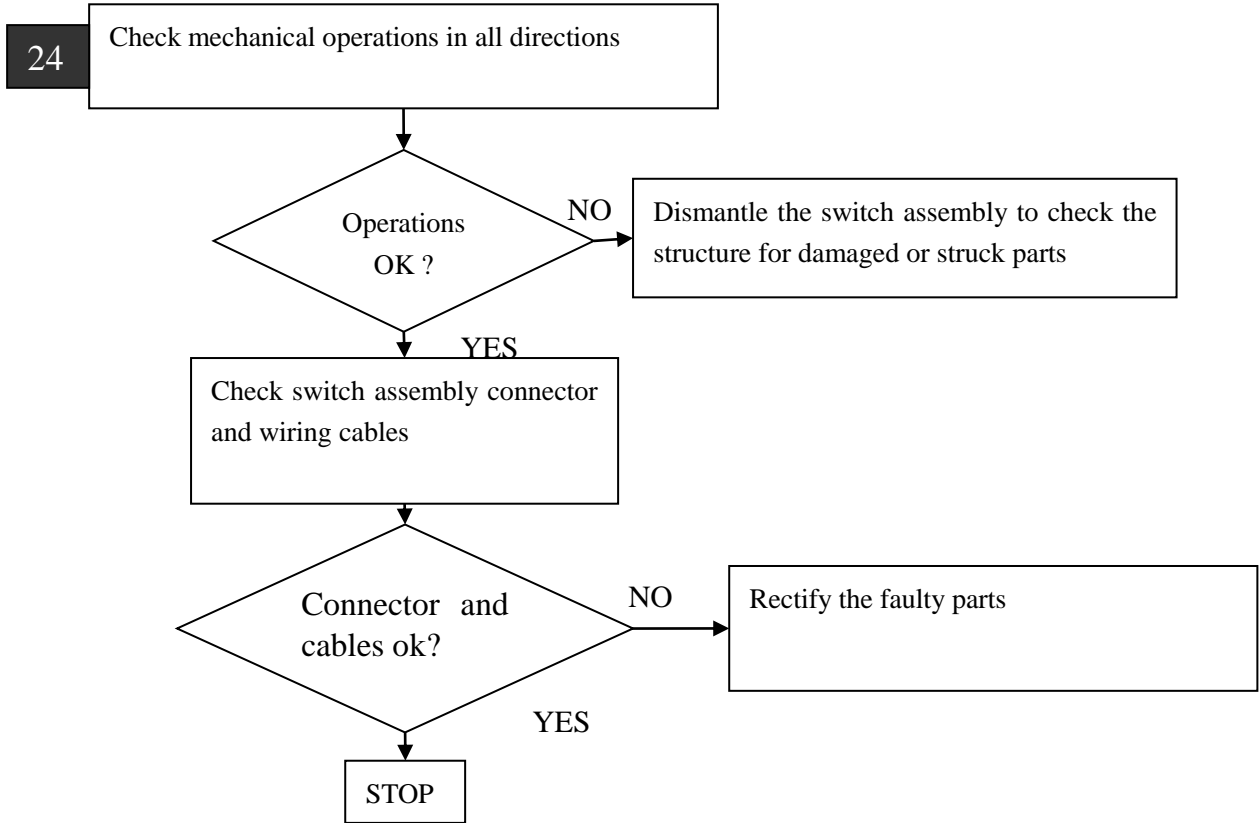

19. Accelerator pedal locking

Refer the main component testing section as defective components testing instructions .

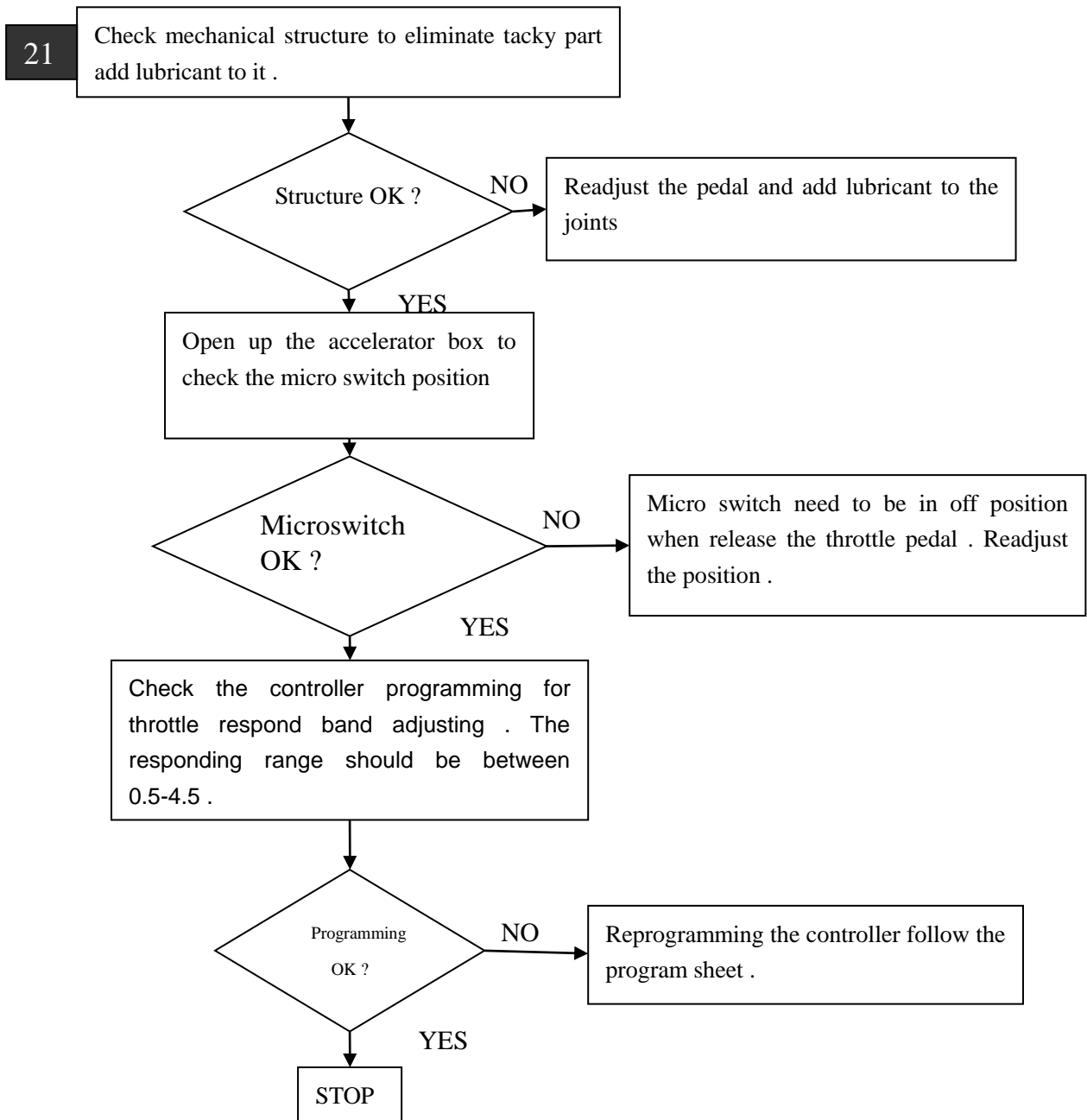

20. Battery relocation

Battery relocation due to battery changes or battery damages .

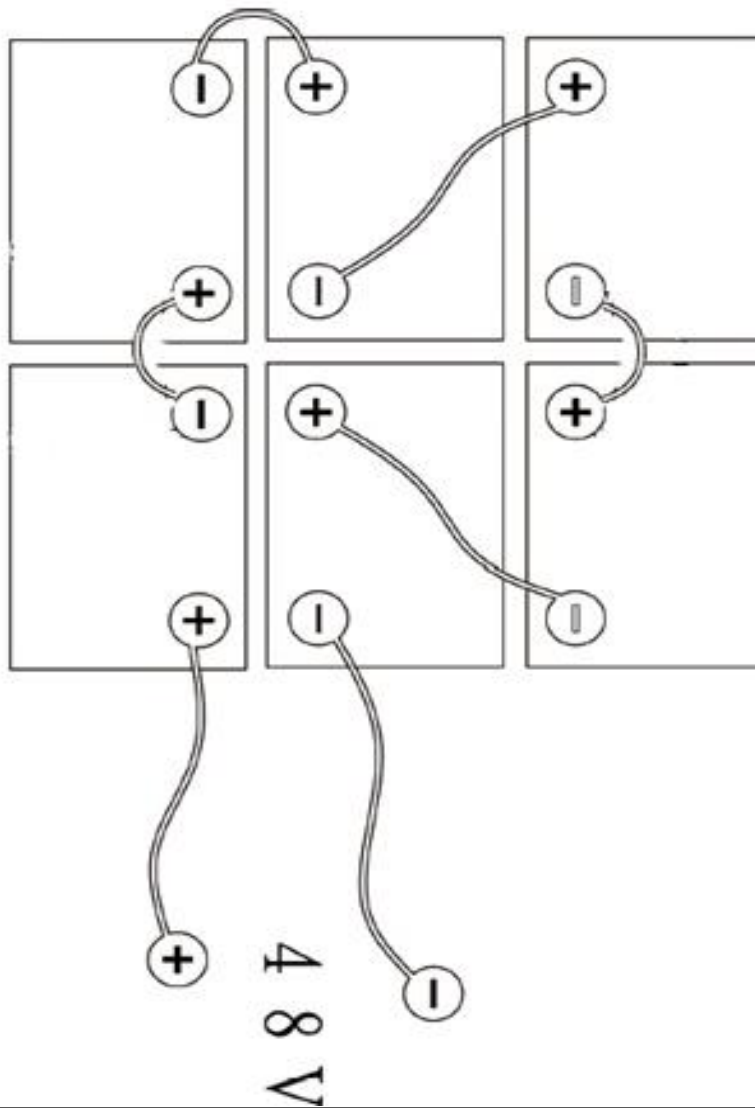

6- Trojan T875 (8V)

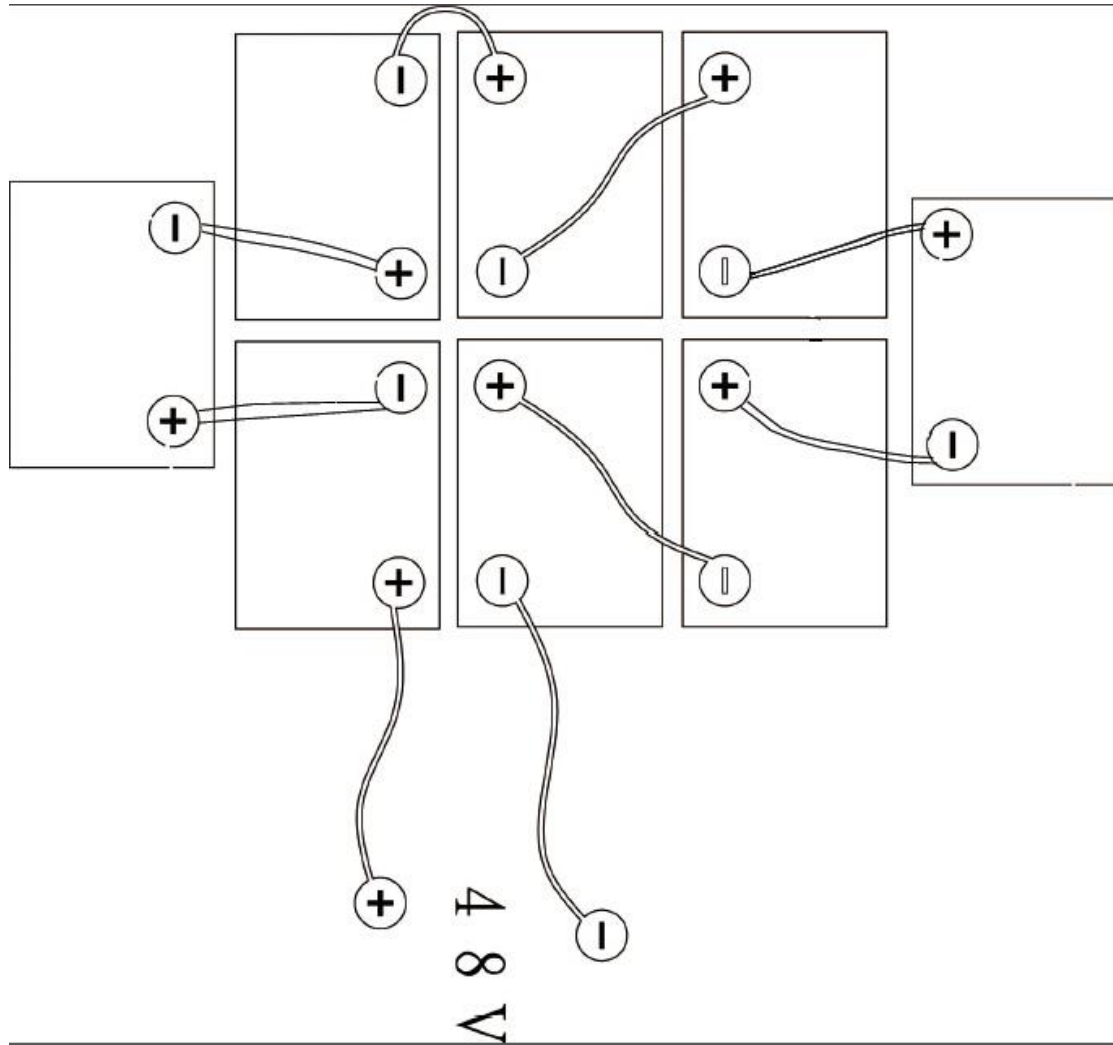

8- Trojan T105 (6V)

MECHANICAL PART



* How to eliminate the mechanical malfunctions

According to the features of the vehicle system , here are the rules that persons intend to operate on the defective cars should follow :

- Always keep only authorized ,trained person to operate on the broke down vehicle.
- Always keep contact with EVOLUTION factory or dealers when have problems that you can not fix .EVOLUTION company have after sales service personnel stand by for your service all the time
- Always have at least one handheld programmer(Type : CURTIS 1313-4001) available for using . Currently all the EVOLUTION vehicles are using CURTIS controller ,for programming the controller or quick diagnose the circuit problem .
For CURTIS controllers that the EVOLUTION vehicles using all the main circuit problems have faulty codes .
One can always use the handheld programmer to change the parameters of the controller, for attaching different performance or for using in different circumstances .
One can always use the handheld programmer to diagnose out the problems and use the trouble shooting table as contrast . The contrast table will tell you which part of the circuit show be checked or replaced .
- Always have enough repairing tools available for testing or repairing .
- Always keep enough vehicle repairing components for storage .
For EVOLUTION vehicles all the components are strictly designed to be highly durable .The most likely break down components are listed and customers should have enough of the these components for replacing the faulty ones .
- Always Use replacing components form manufacturer only .
- Always follow the operation instructions from manufacturer .



4. DO NOT TRY TO OPEN UP THE CONTROLLER .
5. DO NOT TRY TO OPEN UP THE ON BOARD CHARGER .
6. DO NOT TRY TO CHANGE THE CIRCUITRY WITHOUT THE AUTHORIZATION OF THE MANUFACTURER , ILLEGAL MODIFICATION MAY CAUSE SEVER DAMAGE TO THE VEHICLE .

1. Vehicle has wrong wheel camber adjustment

The camber angle and toe-in of both front wheels ,are done by wheel alignment .Intend to equalize each of the front wheels . For all golf carts they have bolts on both side of the front wheels ,used to equalize the turning radius in both directions

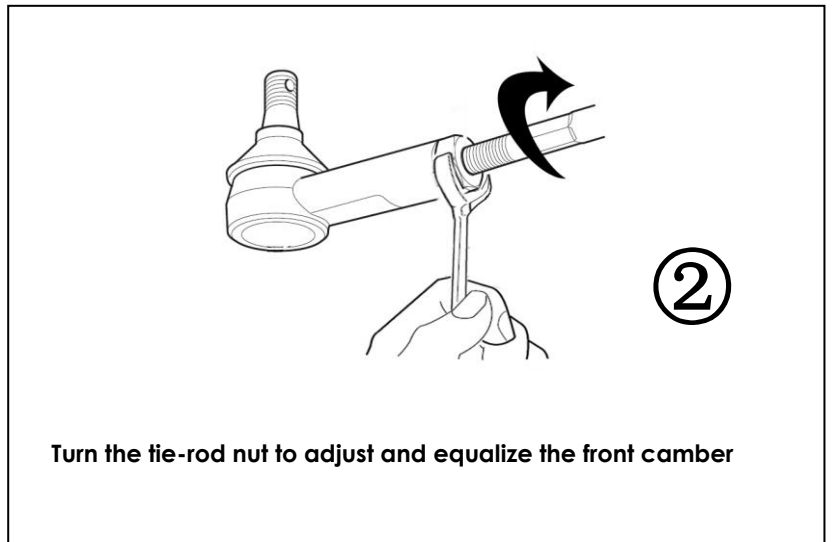
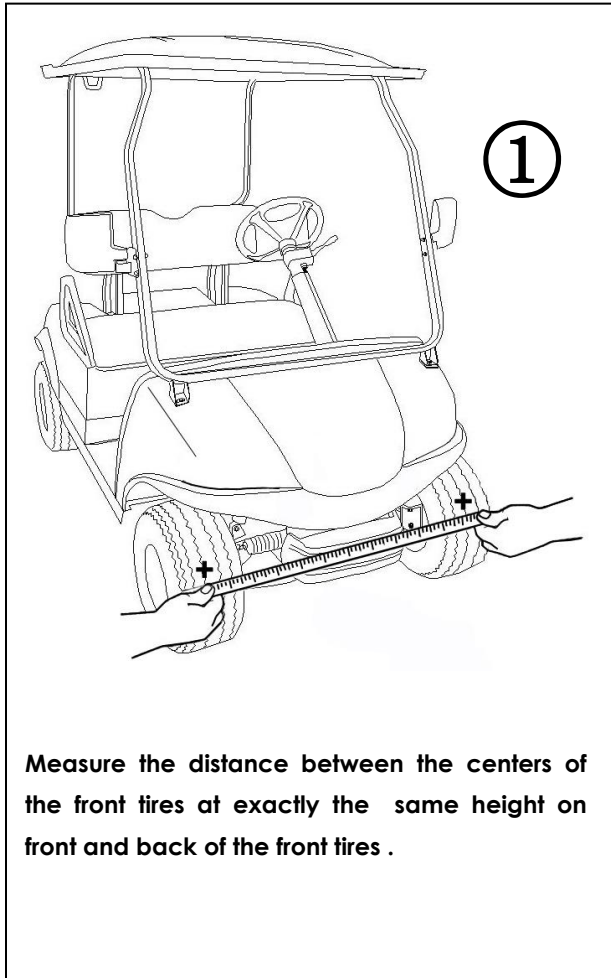

Loose the locking nut on the steering gear box with wrench ,rotate tie rod with locking pliers to increase or decrease the Toe-in scale . Adjust the front tires front distance and back distance ,make the Toe-in scale as follow:

! THE BACK DISTANCE SHOULD BE 3-8mm BIGGER THAN FRONT DISTANCE

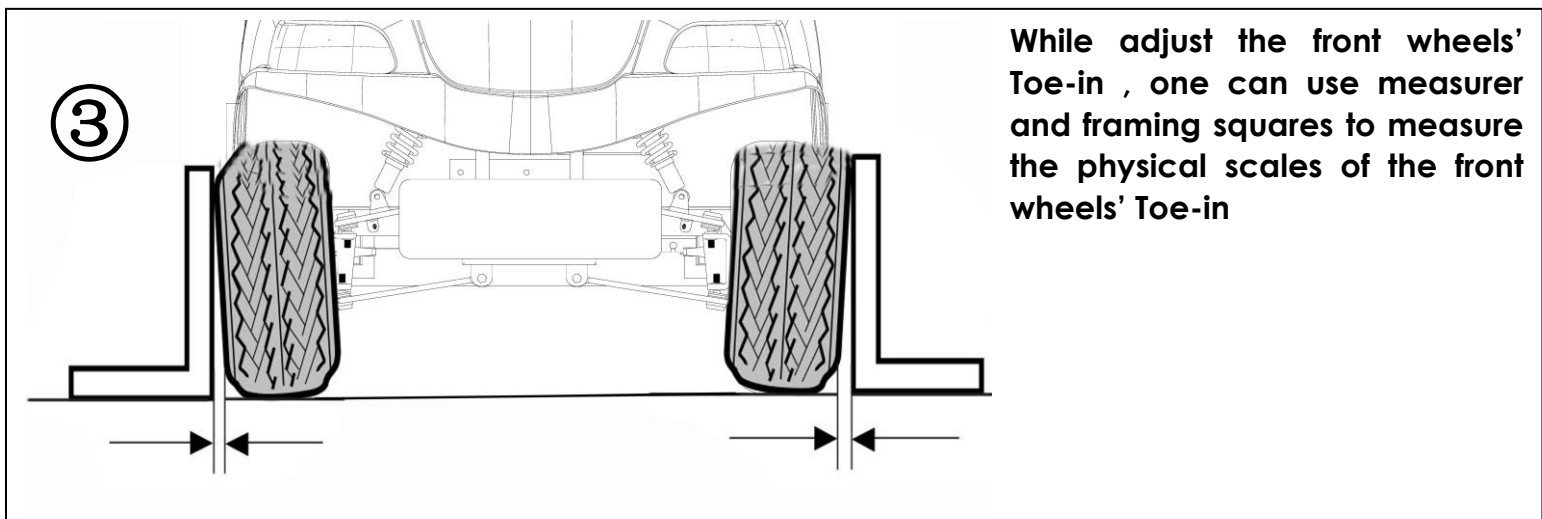
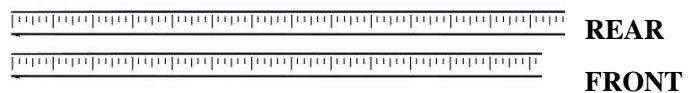

2. Vehicle has stiff steering

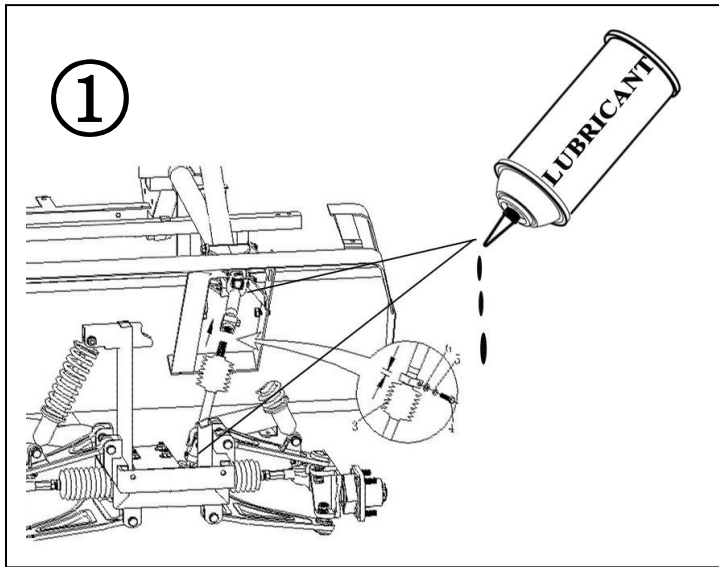

To eliminate the heavy steering wheel malfunction, one can do as followed :

- ①. Check the connection of the steering system be sure all the bolts and nuts are fasten up. Add lubricant to the joints.(FIGURE①)
- ②. Left up the front wheels with a jack.(FIGURE②)
- ③. Loose the bolts that connect the cardan joint to steering column and steering box (FIGURE③)
- ④. Loose the jack put down back the vehicle ,shake the vehicle for multiple times, to make the connection of the universal joints and steering column ,steering gear box perfect. Fasten back the bolts make it solid tight.

Follow the steps above will make the steering wheel getting light

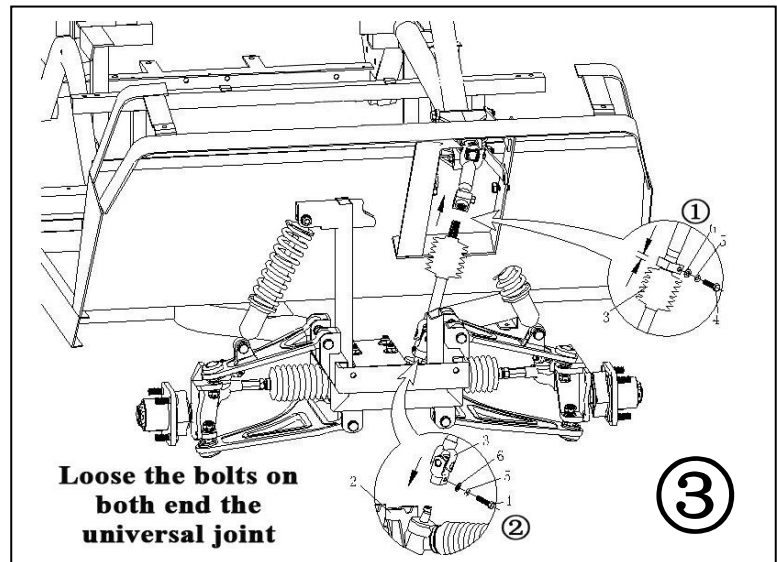
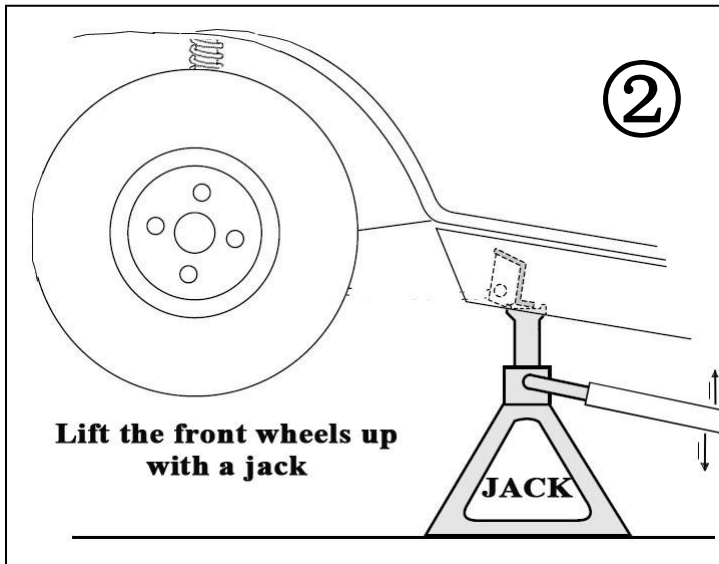

If still can not perfectly make the steering wheel light ,one can operate as followed(FIGURE ④):

Use a chisel and a hammer to hit the connection spot of the joint ball of the steering box and turning knuckle ,for multiple times until the steering wheel is easy to rotate in little strength .

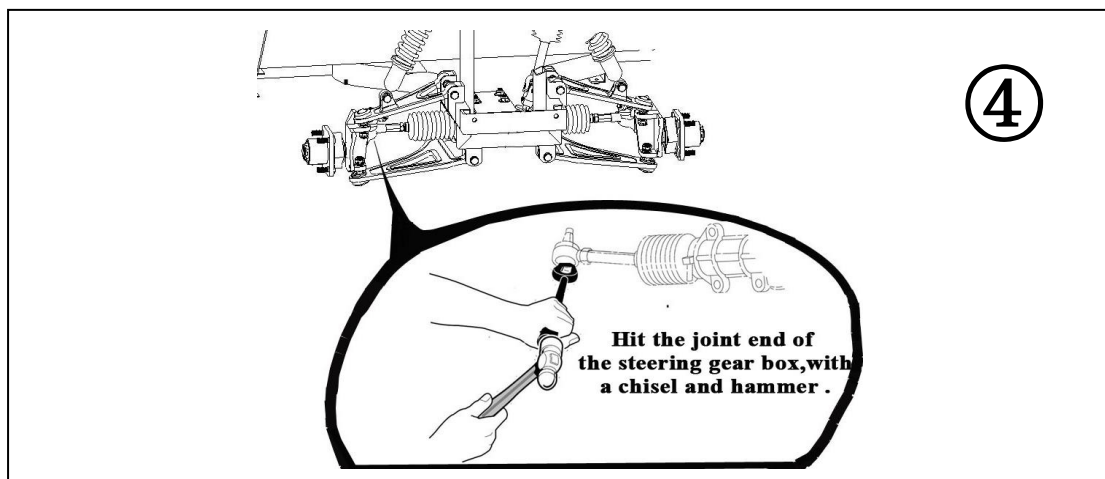

3. Vehicle has stiff shock absorbing ability

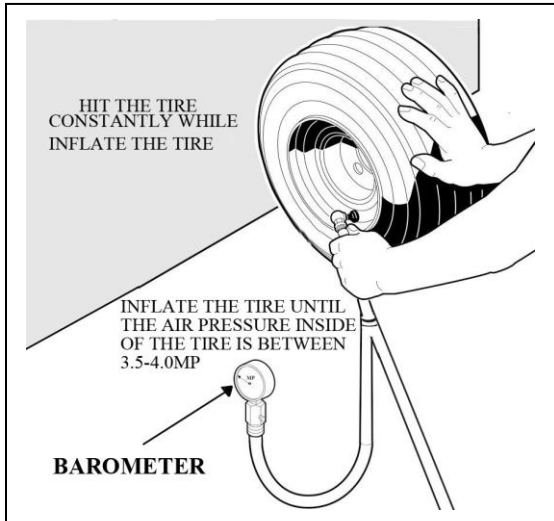

According to the driving road condition inflate and deflate the tire air to keep perfect tire pressure for soft suspension performance .
The standard tire pressure is around 22 PSI . The tire pressure should be adjusted accordingly .

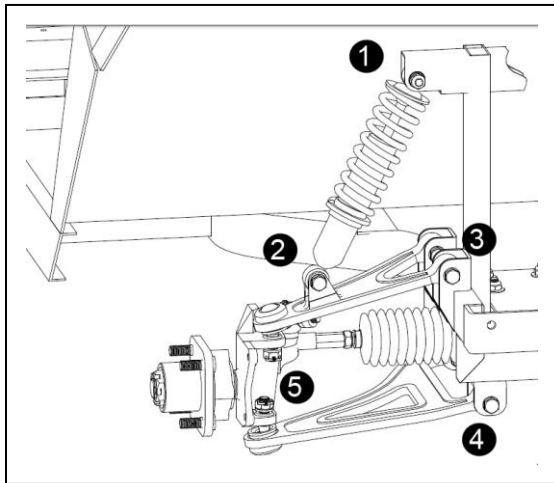

Check the front suspension structure , Loose the bolts for shock absorber Arms a little bit to ensure that the Structure can move freely .

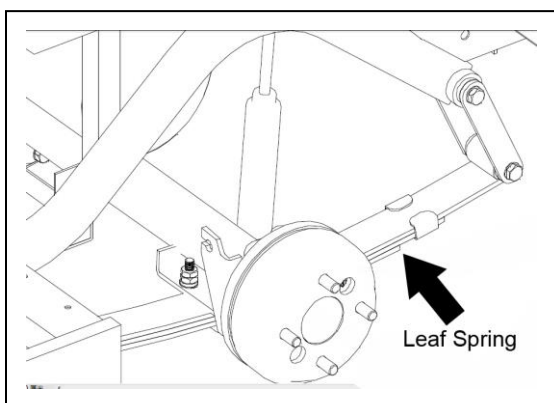

If needed try to dismantle one rear leaf spring off to ensure the vehicle has soft suspension performance .
Refer the vehicle explosive view file for operation instructions.

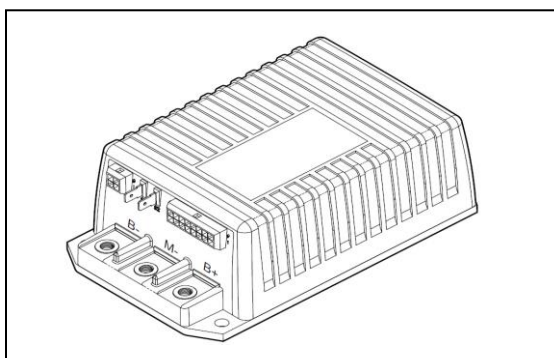

According to circumstances ,try to reprogram the system parameters for better consistent ride performance .
Refer the programming sheet for operation instructions .

5. Parking brake to hard to lock or unlock ,vehicle has heavy brake

Dismantle the height adjusting rod in the back of the parking pedal .

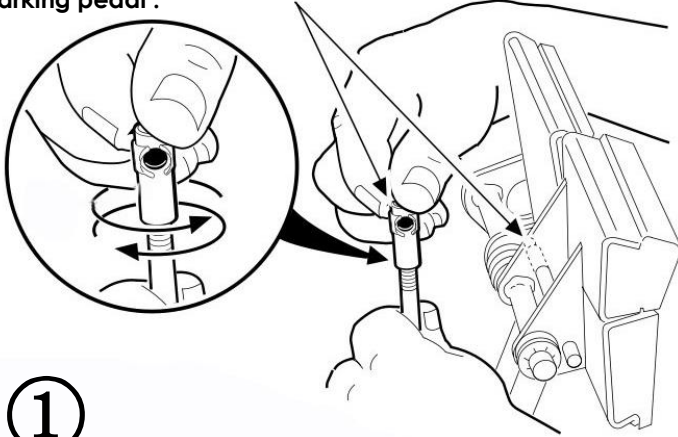

①

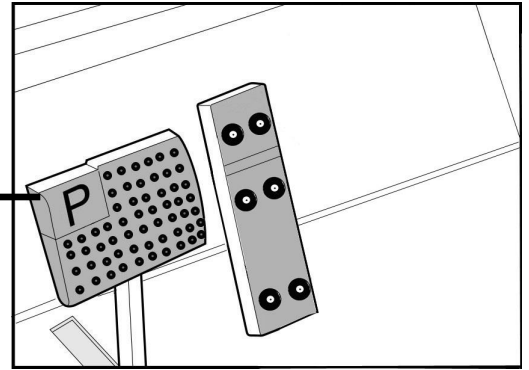

If it is too hard to lock/unlock the parking pedal , one should adjust the brake pedal as the FIGURE ① shows .change the height of the sustain rod of the parking pedal will make the parking pedal easy to lock/unlock.

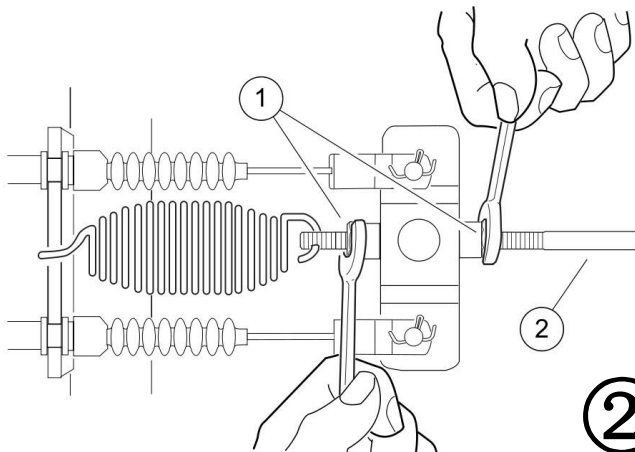

②

If the brake of the vehicle not in proper function ,either too tight or too loose. One can do certain things as followed to adjust the brake into proper functional state.

i. Use wrenches to adjust the tightness of the brake cables (FIGURE ②).

ii. Adjust the tightness of the brake shoes. Open up the brake drum cover , use a screwdriver to adjust the tightness of the brake shoes assembly . Rotate the adjusting wheel in proper scale to make the space between the brake shoes and brake drum minimum (brake shoes are perfect tight but don't rub the brake drum while vehicle loose the brake in running operation)(FIGURE ③).

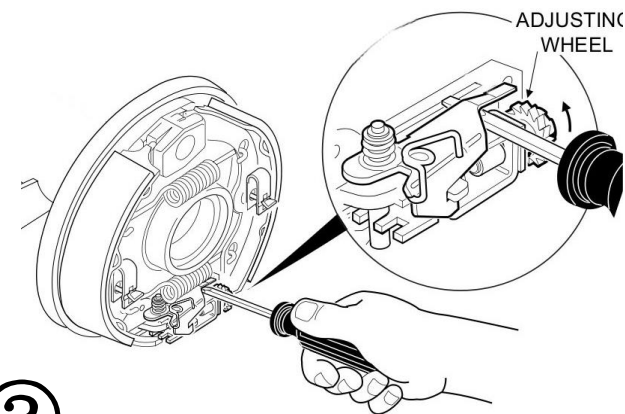

③

6. Steering wheel shakes

①

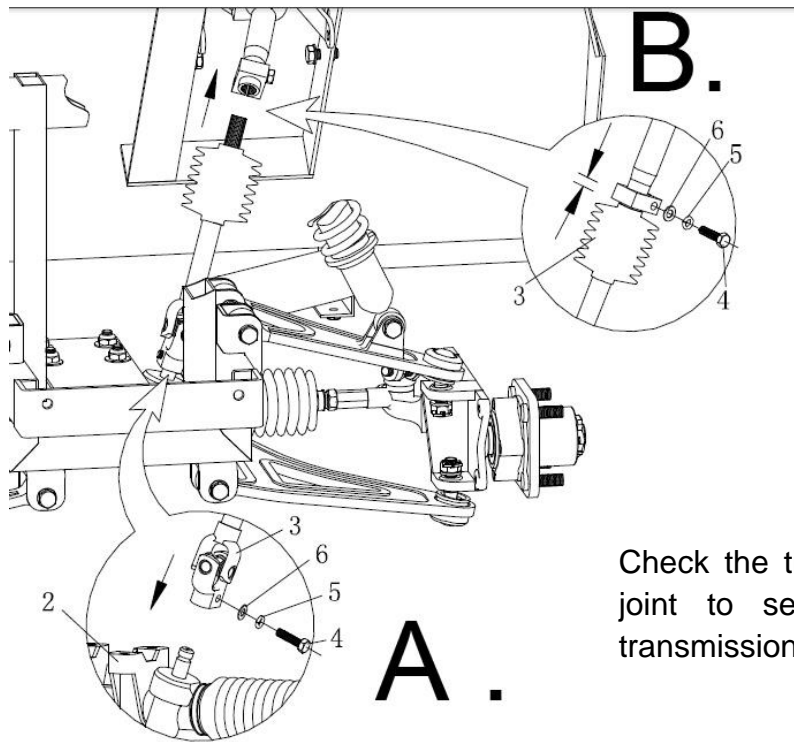

Check the tightness of the Cardan joint to secure steering system transmission .

②

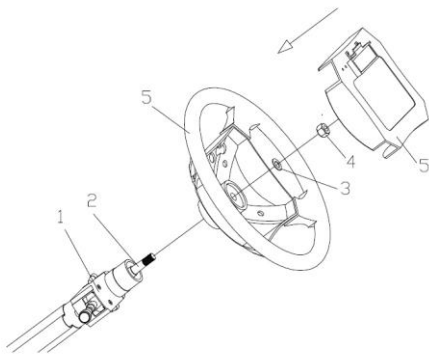

Check the tightness of steering wheel nut .

③

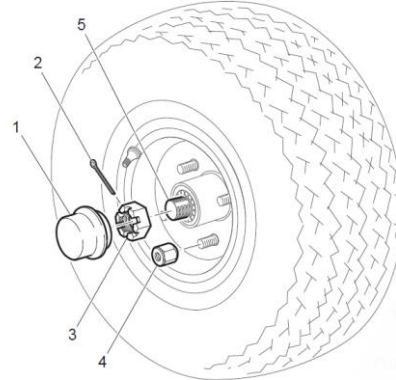

Check the tightness of front hub nut

④

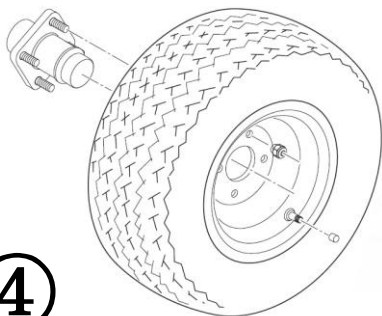

CROSS SEQUENCE

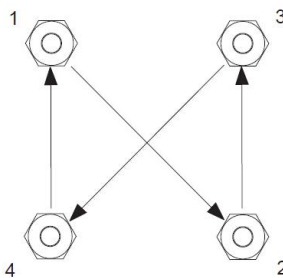

Refit the wheel rims in cross sequence .

7. Steering got stuck when turn to certain angle .

All vehicles have bolts on both side of the front A-arm,used to equalize the turning radius in both directions to make sure steering has smooth turning

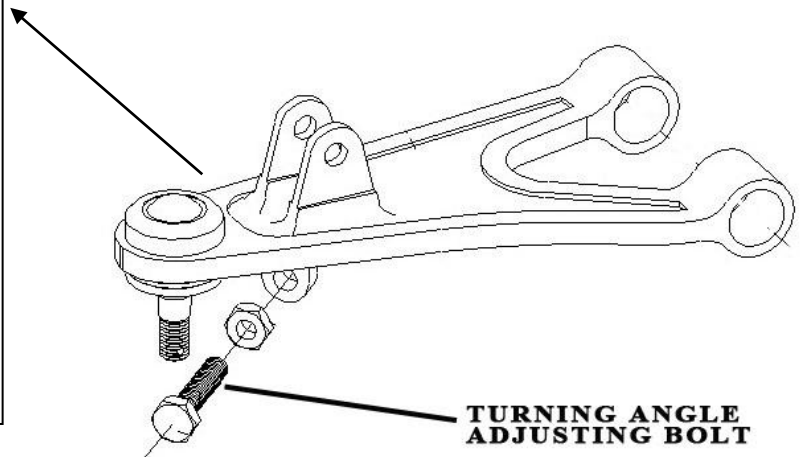
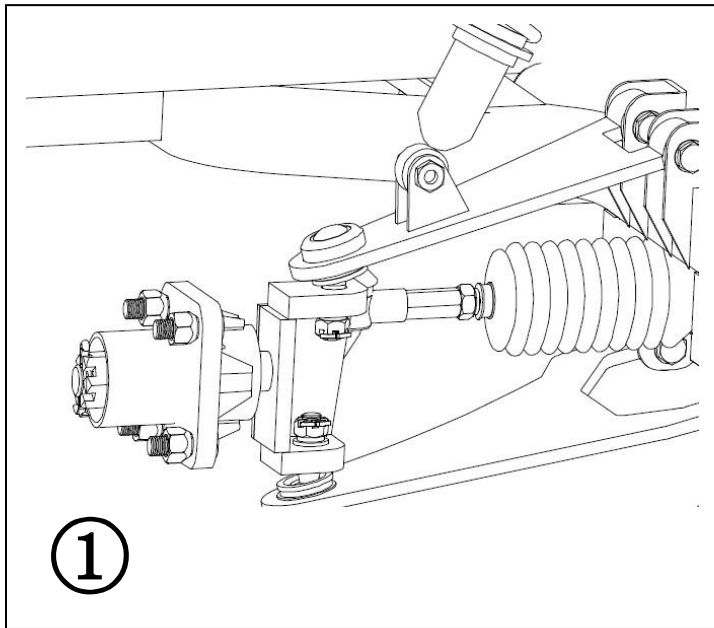

Loose the adjust bolts on the steering gear box with wrench ,rotate the bolts to equalize the turning radius in both directions

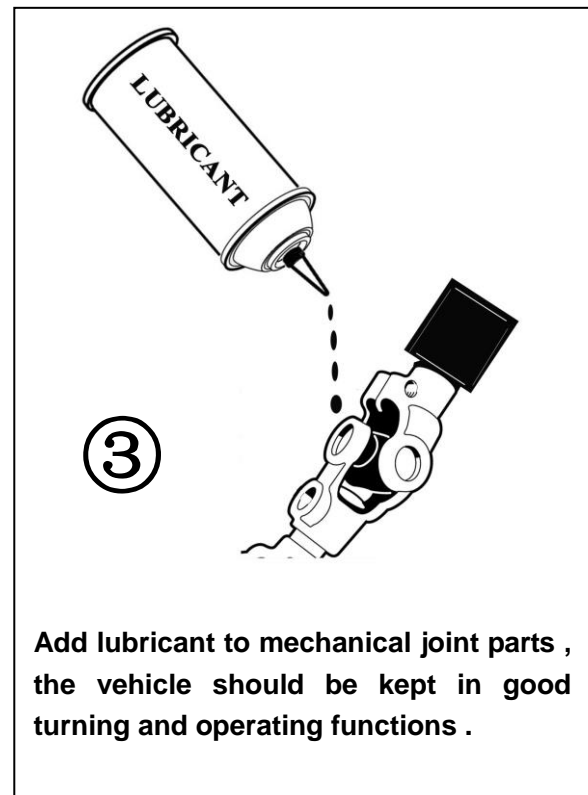
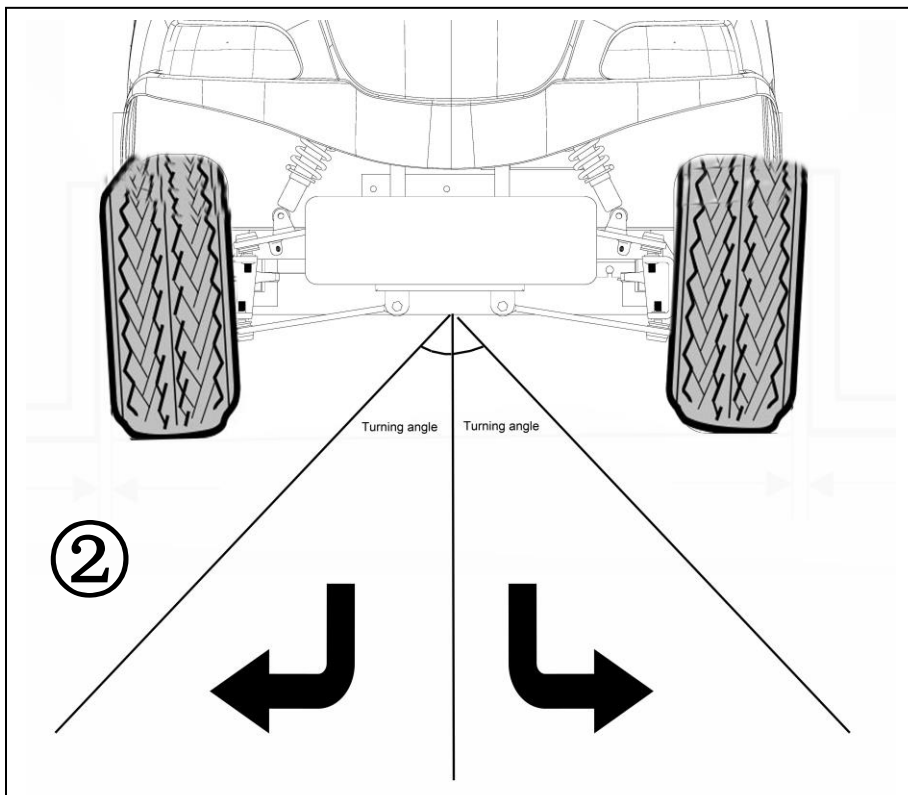

Add lubricant to mechanical joint parts , the vehicle should be kept in good turning and operating functions .

The turning angles have been set at maximum scale . For customers who want to change the turning angles .Can follow the instructions (Figure ②).

8.Brake pedal or throttle pedal sticky or stuck

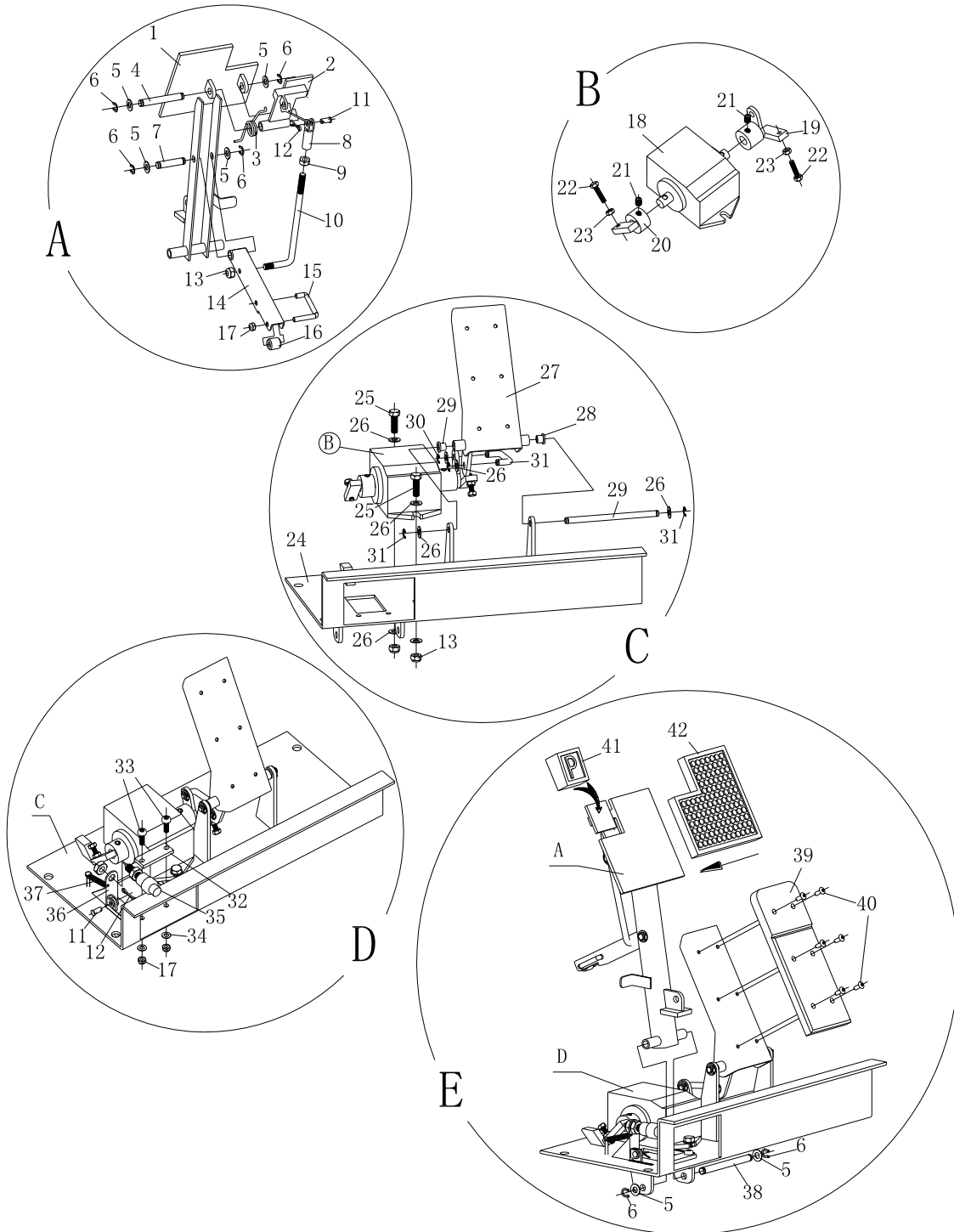

ITEM	CODE	NAME	QTY
1	EV32G-7011100	BREAK PEDAL	1
2	EV32G-7010900	BREAK PRARTS	1
3	EV32G-7011300	PARKING RESET SPRING	1
4	EV32G-7011000	COTTER	1
5	Φ10	WASHER	6
6	Φ8.5	JUMPING SPRING	6
7	EV32G-7011500	PIN	1
8	EV32G-7010201	PARING BREAK UPPER DRAG HOOK	1
9	M8	HEX HED NUT	1
10	EV32G-7010202	PARING BREAK LOWER DRAG HOOK	1
11	EV32G-7010203	PIN	2
12	Φ1.5×25	COTTER	2
13	M8	HEX HEAD ANTI-SLID NUT	3
14	EV32G-7010101	PALLET	1
15	EV32G-7010102	U SHAPE BOLT	1
16	EV32G-7010103	ROLLER	1
17	M6	HEX HEAD ANTI-SLID NUT	3
18		ACCELERATOR BOX	1
19	EV32G-7010501	ACCELERATOR LUMP	1
20	EV32G-7010502	UNLOCK LUMP	1
21	M8×15	SUNK HEXAGON SOCKET-HEAD CAP SCREWS	2
22	M6×35	HEX HEAD BOLT	2
23	M6	HEX HEAD NUT	2
24	EV32G-7010400	BASE BOARD ASSEMBLY	1
25	M8×25	HEX HEAD BOLT	2
26	Φ8	WASHER	8
27	EV32G-7011701	ACCELERATOR PEDAL	1
28	EV32G-7011703	PEDAL BUSH	2
29	EV32G-7011800	PEDAL PIN	1
30	Φ7.5	JUMPING RING	6
31	EV32G-7010600	LINKAGE POLE	1
32	EV32G-7010300	CRACH ROLL	1
33	M6×20	PHILIPS PAN HEAD BOLT	2
34	Φ6	WASHER	2
35		BREAK SWITCH	1
36	EV32G-7010405	BREAK SWITCH SOCKET	1
37	Φ1.5	TENSION SPRING	1
38	EV32G-7011600	PIN	1
39	EV32G-7011702	ACCELERATOR PEDAL COVER	1
40	GB12618	RIVET	6
41	EV32G-7010901	PARKING PEDAL COVER	1
42	EV32G-7011101	BREAK PEDAL COVER	1

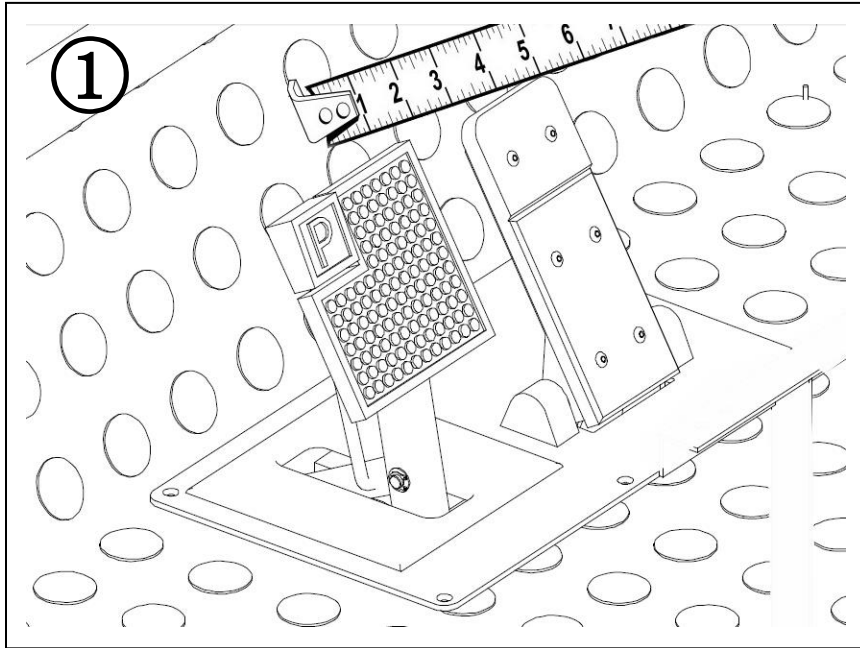

Adjust the angle of the throttle ,make sure it have enough clearance for pedal movement .

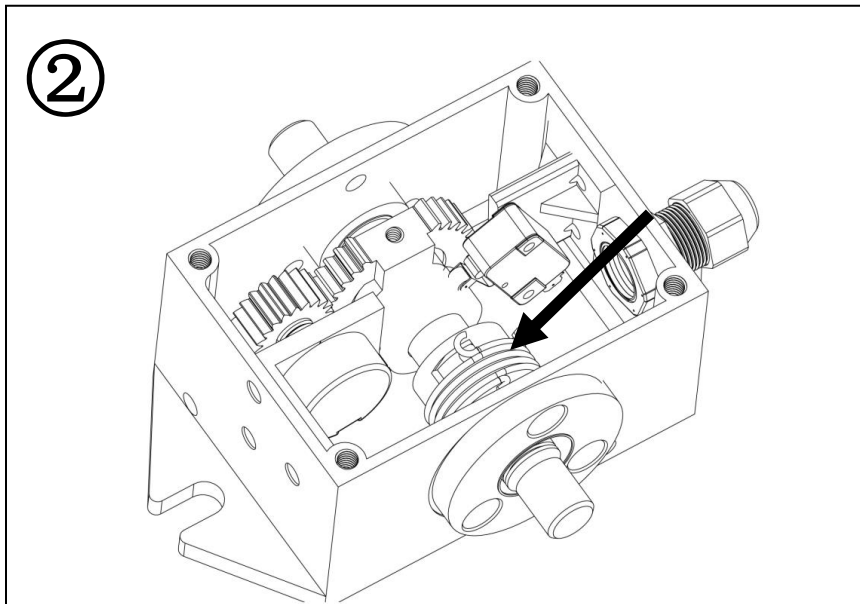

Check the spring that attached to the shaft inside the Accelerator box make sure the spring is highly flexible and has grease on it .

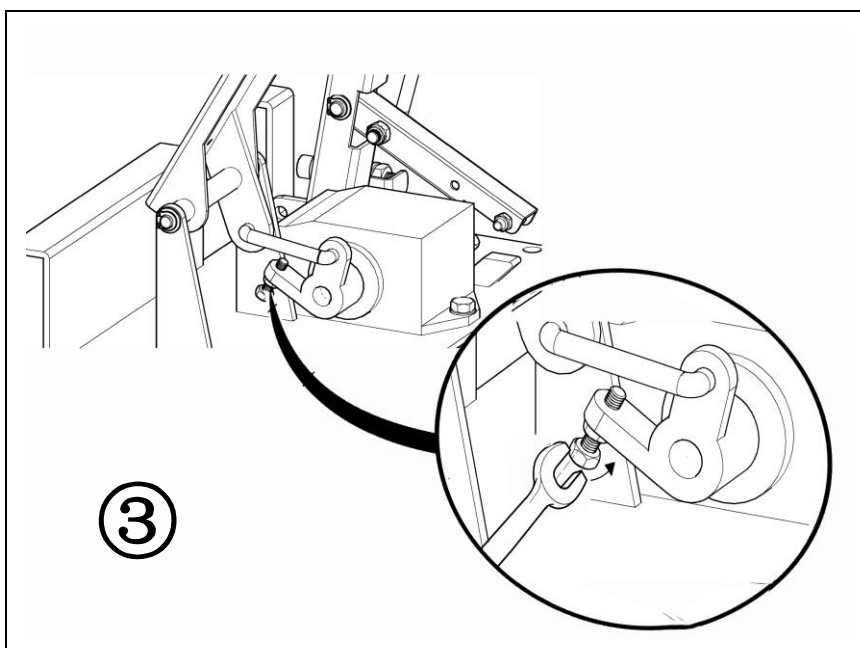

Readjust the stop bock of the throttle pedal make sure the pedal do not have too short or too long distance of pedaling .

9. Vehicle has bad braking ability .

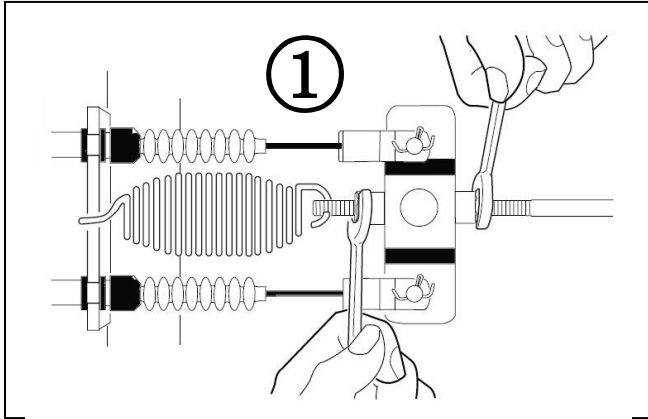

Adjust the tightness of the brake cables pulling rod ,make sure the cables are properly tightened .

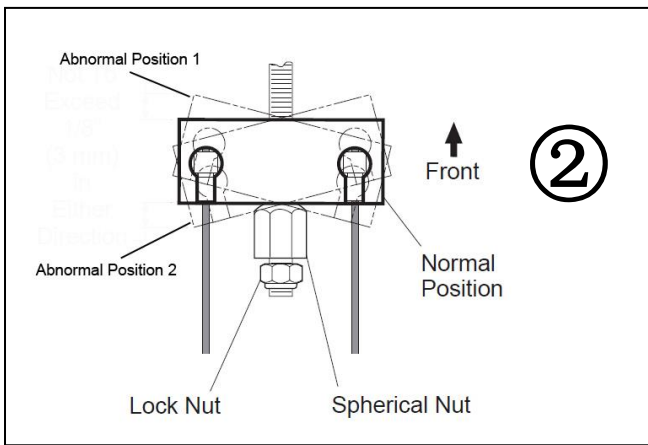

Adjust the balance block to make sure the blocks are evenly adjusted .

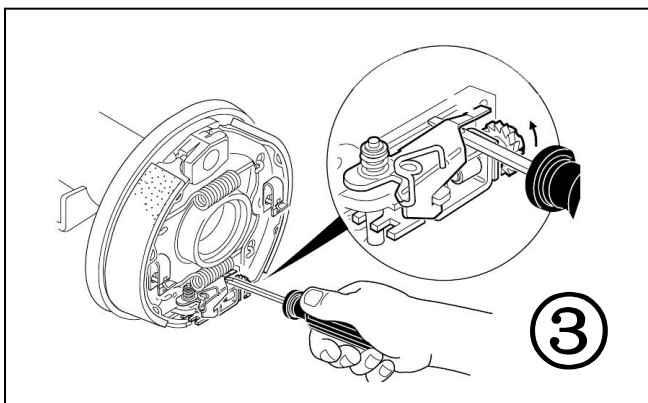

Adjust the tightness of the brake shoes ,make sure the brake shoes are in proper positions .

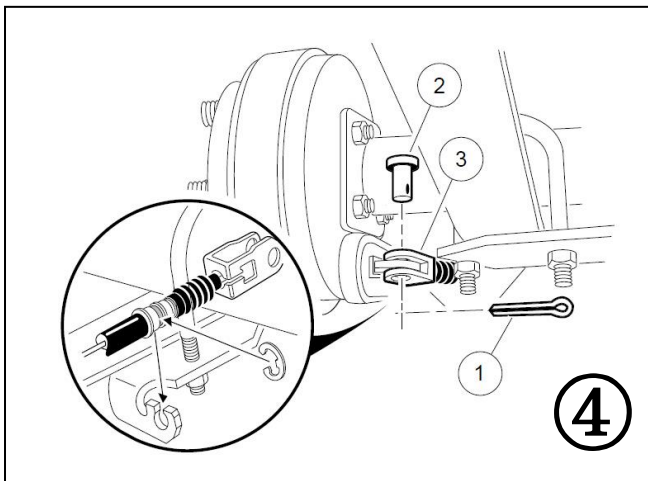

Check the brake pins attached to brake assembly make sure this pin is not damaged or stripped .

Check the thickness of brake shoes .

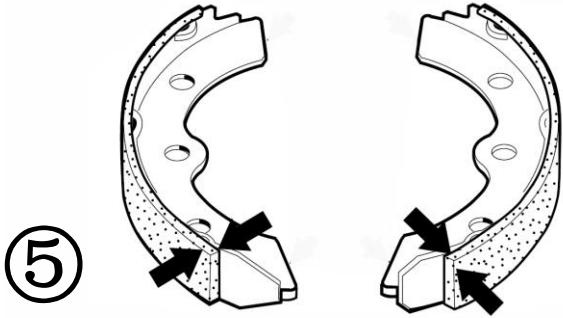

Check the thickness of the brake shoes make sure the shoes are in good condition . Otherwise replace the brake shoes .

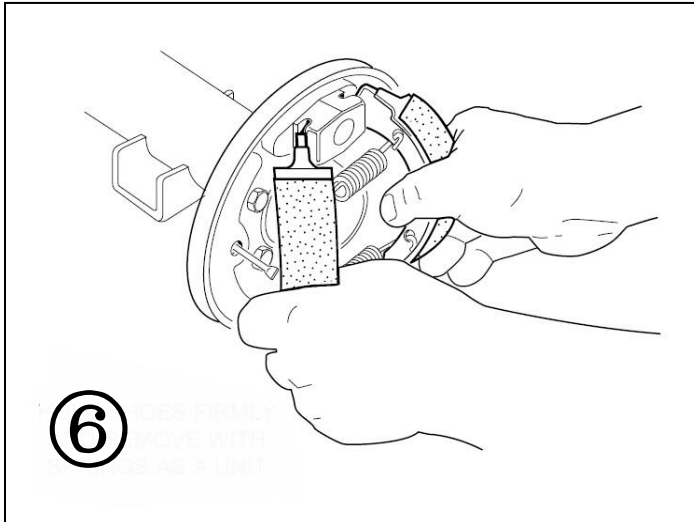

Check the brake pins attached to brake assembly make sure this pin is not damaged or stripped .

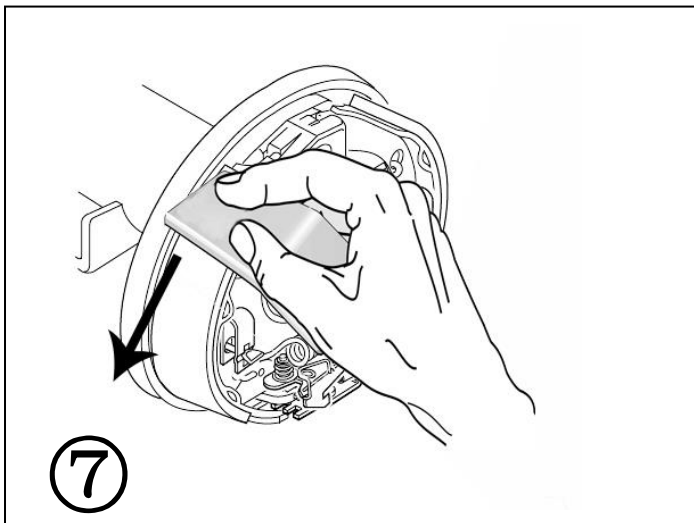

Check the brake pins attached to brake assembly make sure this pin is not damaged or stripped .

10. Brake shoes glazed

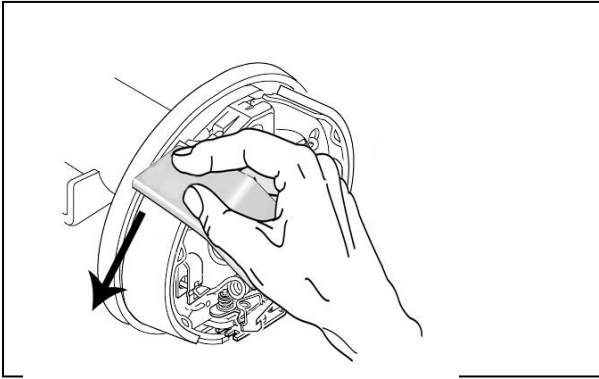

Paper sand the brake surface to get rid of greasy and foreign objects .

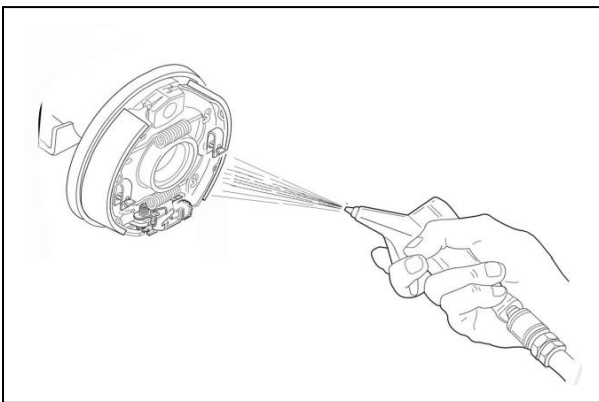

Clean the brake shoes with a air nozzle to clean all the shreds and small objects out .

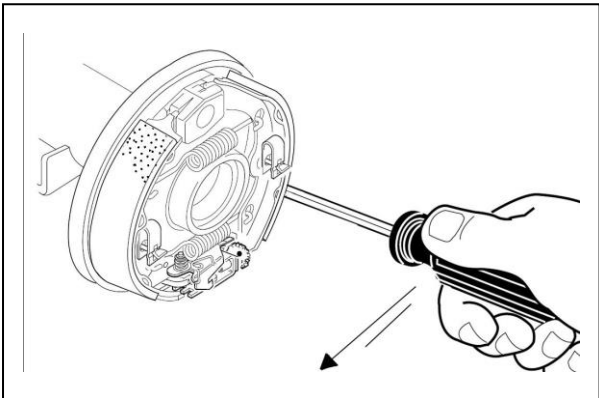

Readjust the clearance distance of brake shoes .

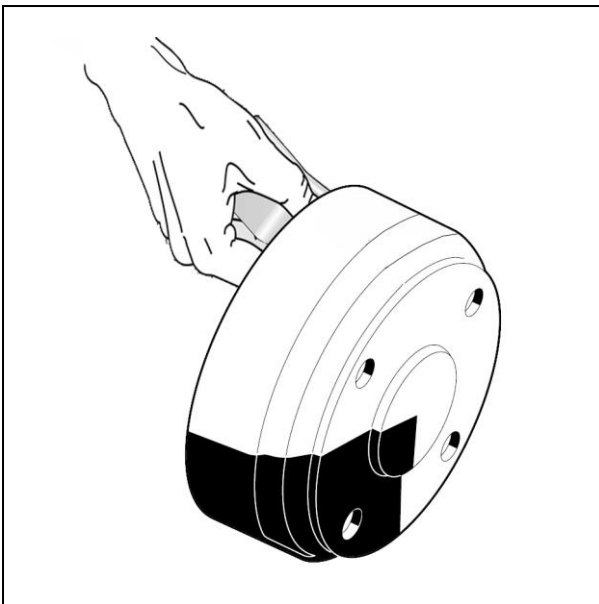

Use rough sand paper to sand out the brake drum surface to smooth out the surface .

11. Vehicle brake damaged or sticky

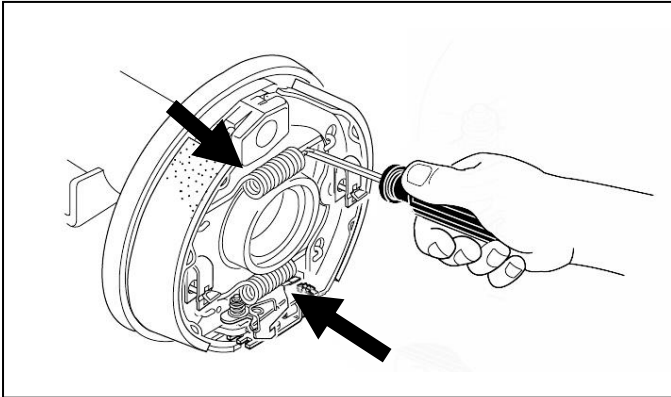

Check flexibility of the brake shoe springs make sure the springs are properly flexible .

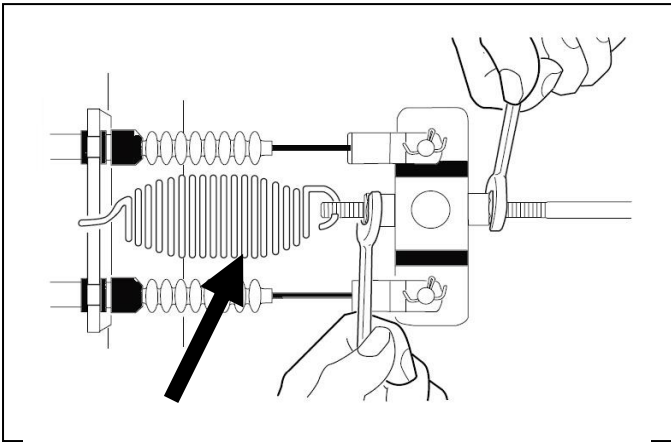

Adjust the tightness of the brake cables pulling rod ,make sure the cables are properly tightened .

Check the thickness of brake shoes .

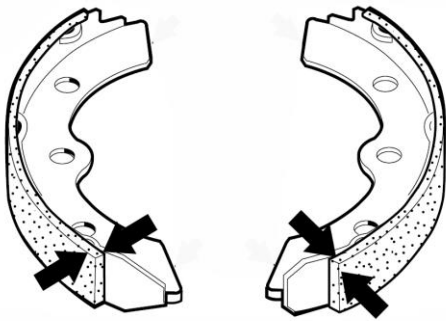

Check the thickness of the brake shoes make sure the shoes are in good condition . Otherwise replace the brake shoes .

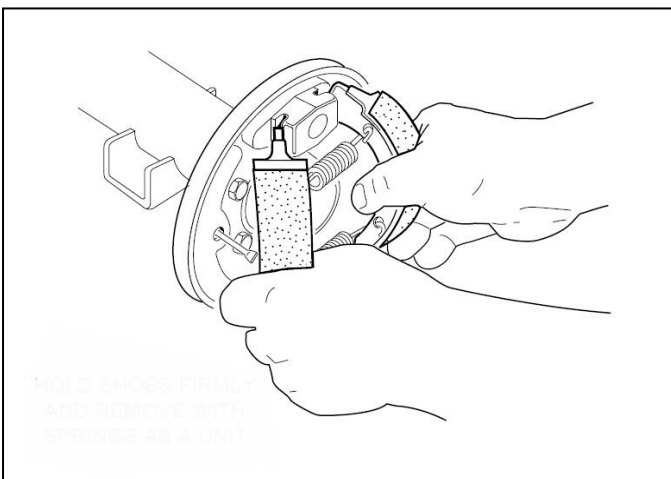

Remove and replace the extremely worn out brakes shoes if needed

12. Vehicle has unequal braking (one wheel locks while other rotates)

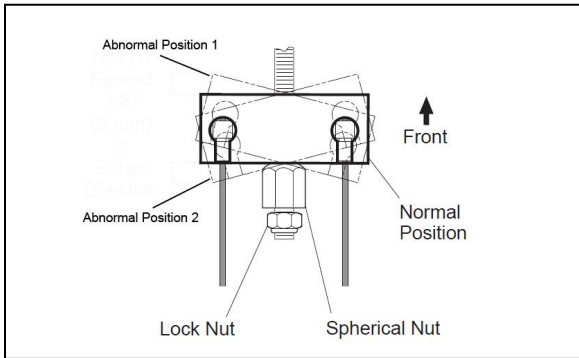

Adjust the balance block to make sure the blocks are evenly adjusted .

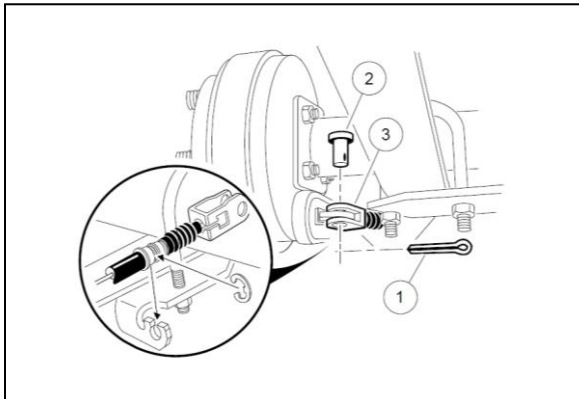

Check the brake pins attached to brake assembly make sure this pin is not damaged or stripped .

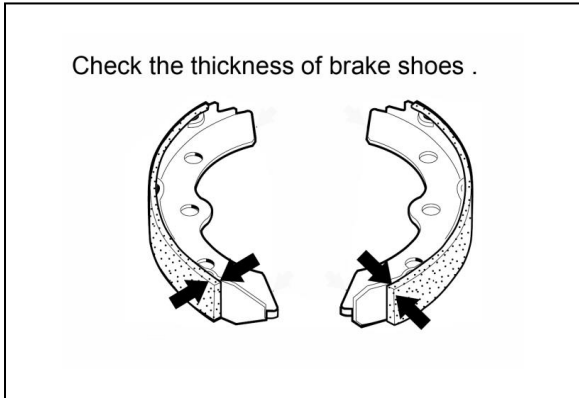

Check the thickness of brake shoes .

Check the thickness of the brake shoes make sure the shoes are in good condition . Otherwise replace the brake shoes .
Adjust the tightness of the brake shoes ,make sure the brake shoes are in proper positions .
Readjust the clearance distance of brake shoes .

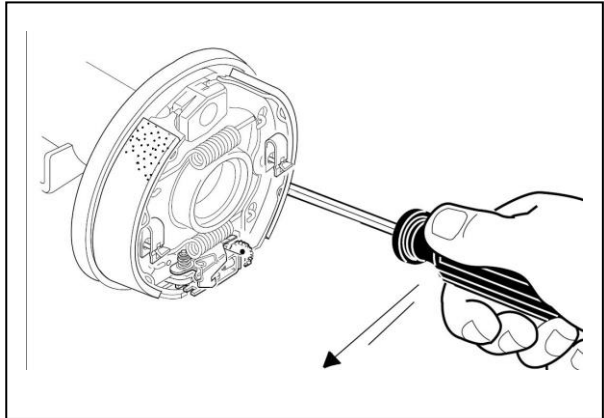
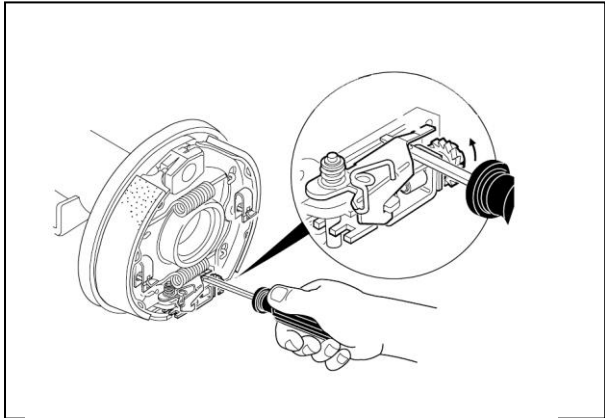

13.Noisy rear axle .

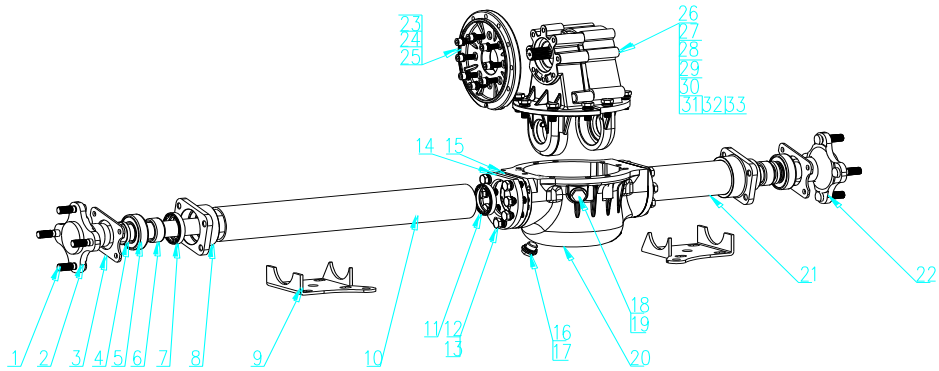

33	Alignment pin	4	□10*12		13	□10 snap washer	16		
32	Air Valve	1	PT1/8		12	M10 hex bolt	16	M10*30	
31	□8 Snap washer	6			11	seal	2	□52*□28*8	
30	□8 washer	6			10	Long sleeve	1	16Mn	
29	M8 allen bolt	6	M8*45		9	Spring base	1+1	Q235	
28	□10 snap washer	16			8	Bearing base	2	45	
27	M10 hex bolt	10	M10*25		7	Seal	2	□55*□42*8	
26	Reduction gear assembly	1			6	fastening part	2	45#	
25	□8 Snap washer	8			5	deep groove ball bearing	2	6206	
24	M8 allen bolt	8	M8*20		4	Bearing gasket	2	45#	
23	Motor connection plate	1	ADZ12		3	Bearing holder	2		
22	Short shaft	1	40Cr		2	Long Shaft	1	40Cr	
21	Short shaft sleeve	1	16Mn		1	Stud	8	M12*1.25*40	
20	Central part	1	ADZ12		Item	CODE	Name	Qty	Material & Spc
19	Inlet bolt	1	M18*1.5						Note
18	Inlet bolt oil seal	1							
17	outlet bolt	1	M16*1.5						
16	Oil seal	1							
15	Paper seal	2							
14	Reduction gear head	2							

14. Vehicle has unevenly worn out tires

Causes

1. The tires' pressure is insufficient , make sure the tires have sufficient inflated air . The pressure should be under the rational level of the tires specifications (marked on the tires)
2. ★The Toe-in scale is not right. If the Toe-in scale is either too big or too small will cause the rubbing .
3. ★The camber angles are not right . This the most specific reason may cause massive tire worn out .
4. ★The suspension system aged , and the front bearings have worn out , the space around bearings is too big. Tires shaking while driving .
5. Distance between tires .Left side ,Right side are different .

Camber angle

Front independent suspension wrong camber angle .

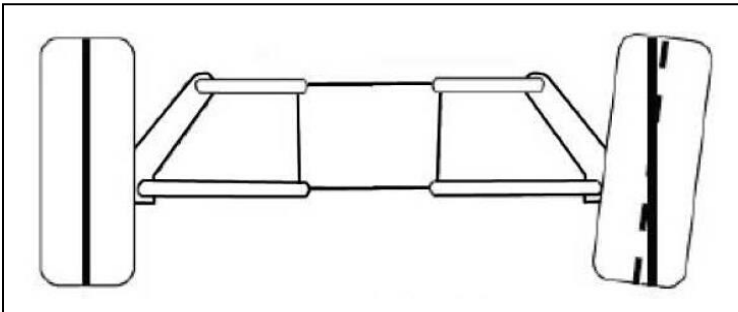

Wrong camber angle ,will cause unevenly wore out

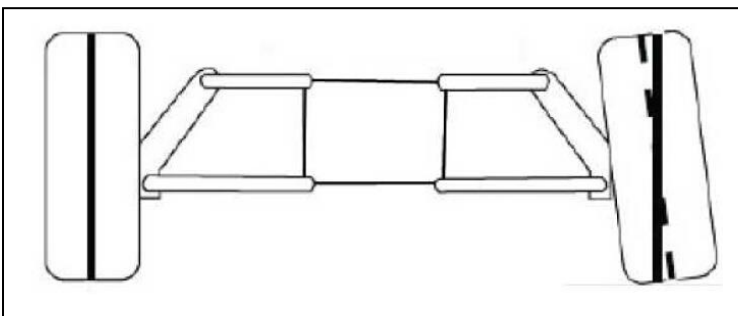

Wrong camber angle ,will cause unevenly wore out

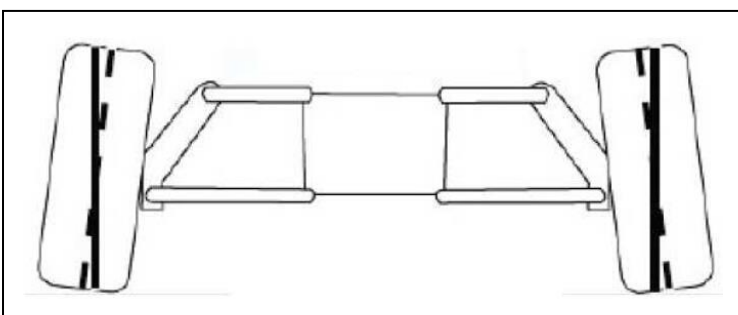

Wrong camber angle ,will cause unevenly wore out



Front independent suspension right camber angle .

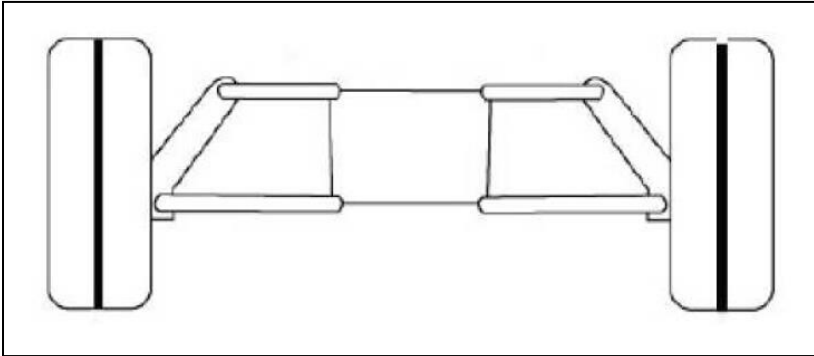

Right camber angle ,will not cause unevenly wore out

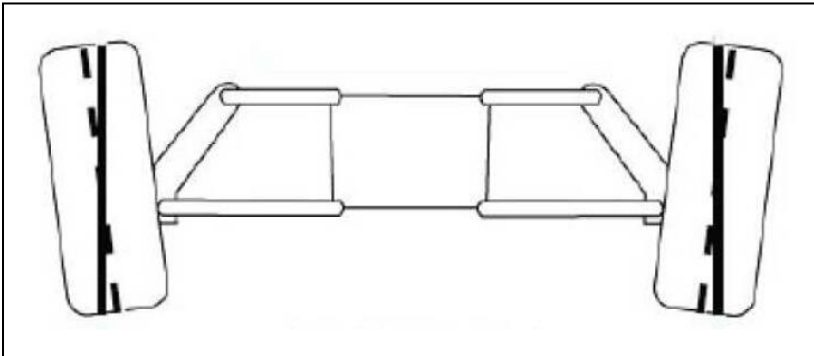

Right camber angle ,will not cause unevenly wore out



Why the vehicle have camber angle ?

For double wishbone suspension all have camber angle this the most significant feature of this kind of suspension .

★ Why we need Toe-in ?

Cause for double wishbone suspension have camber angle. The tires' contact with road have angle too, while rotate. So if we need to fix this kind of problem ,we need toe-in to offset the angle problem causing tire rubbing . Per different carts , toe-in adjustment normally be fixed in certain scale .

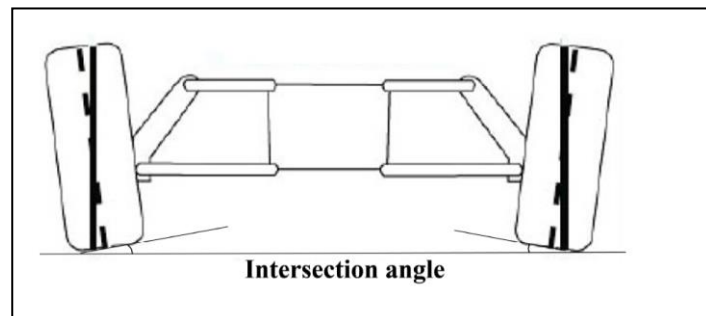

Why my vehicle always worn out so quickly ?

After using for certain time ,the bearings may worn out. The suspension may aged . If the A-arms or vehicle chassis suffered form impact and be twisted ,then the angle of the wheels may changed . If the vehicle have worn out bearings and the wheel shakes whether rotates . All of these reasons may cause rubbing .

How can I fix the vehicles have tire rubbing problem ?

1. readjust the camber angle .
- 2.check the suspension system especially the bearings inside of front hub .Make sure the wheels move straightly while driving, no wavy path of tires moving ,and no shaking .
- 3.Adjust the toe-in
- 4.Measure the distance between the front wheel shaft and rear wheel shaft . Make sure Left side and Right side have no big difference.

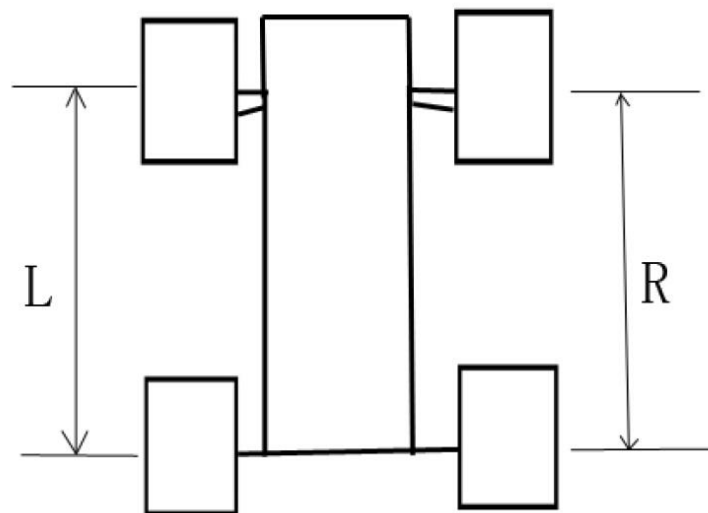

If the vehicle is put away for storage for long time . certain things need to be done to prevent vehicle from malfunctions or other lose.

Please always follow the methods shown below .

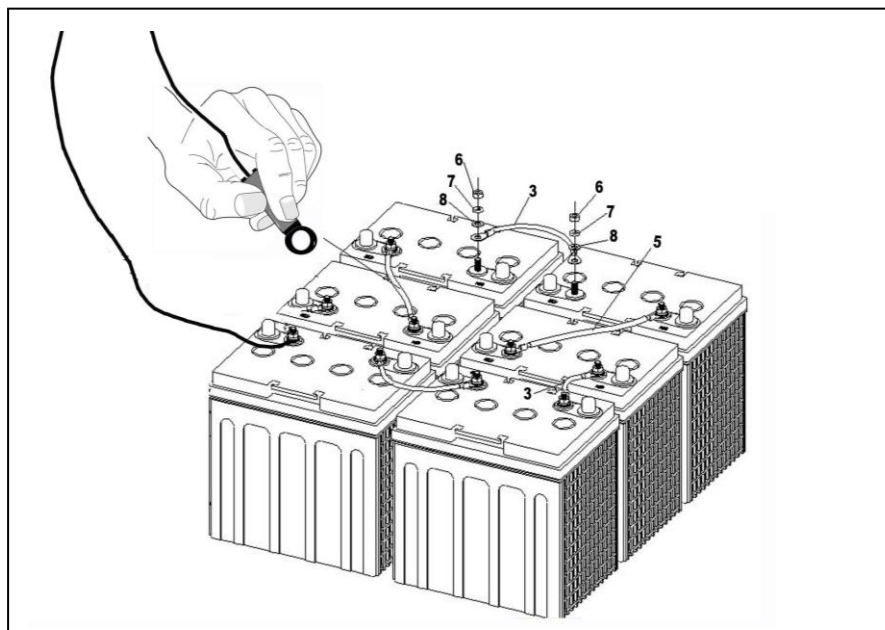
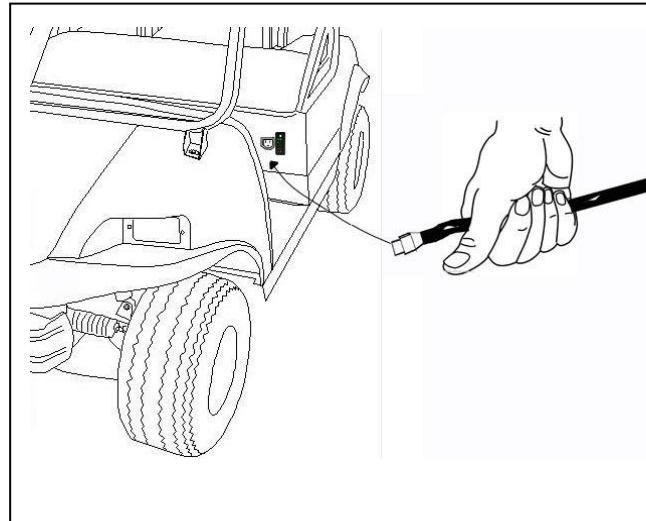

I . Keep vehicle in dry and ventilated place , keep it from rain

II .Remember to charge the batteries fully before put away vehicle

III.Disassemble the connection cables between batteries and controller

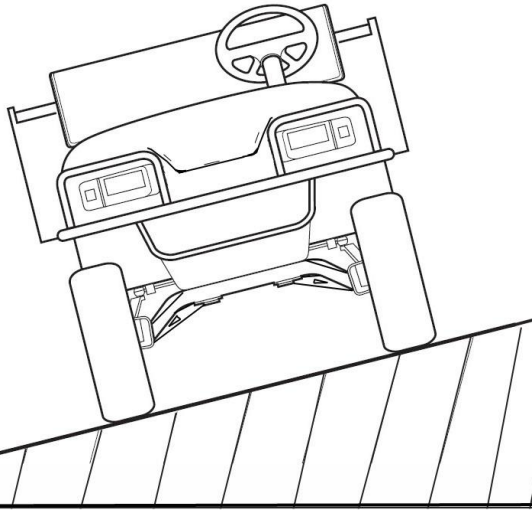

Max slope accessing angle :15%

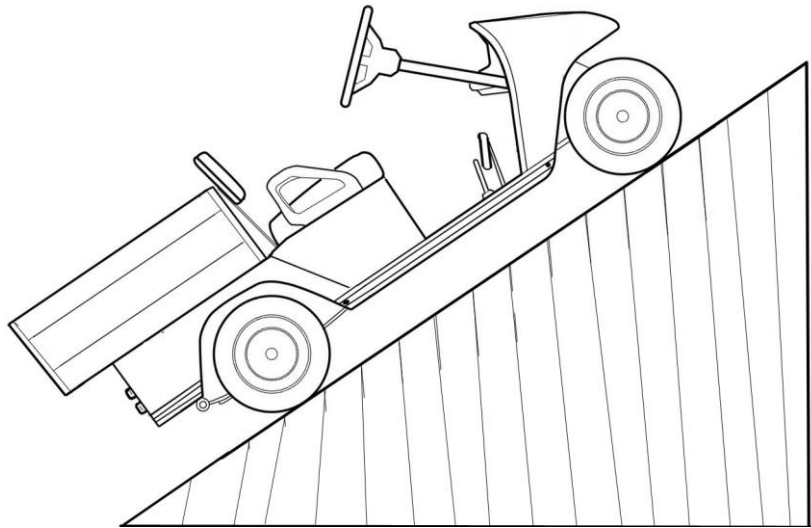

Max ramp angle :25%

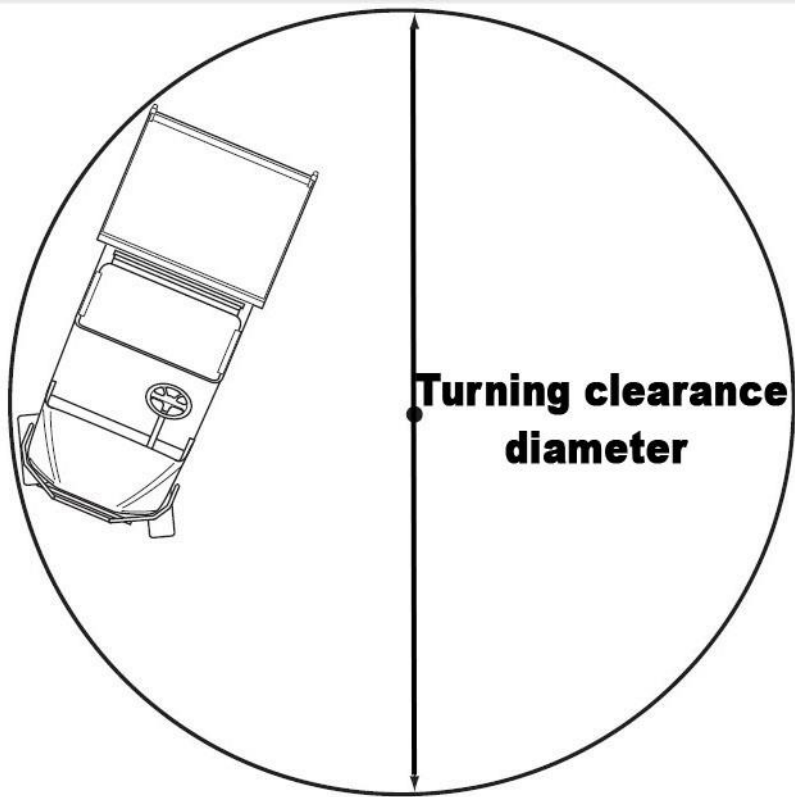

Turning clearance diameter:7m



A series of horizontal lines for writing, starting from the top of the page and extending to the bottom. The lines are evenly spaced and cover the majority of the page area.



A series of horizontal lines for writing, starting from the top of the page and extending to the bottom.

APPENDIX 1: The programming data sheet

CURTIS 1232SE CONTROLLER PROGRAMMING						
PARAMETER ITEMS					4KW	5KW
PARAMETERS						
	Mode Settings					
		Frequency at 6000RPM			300	300
		Brake Strength			20	20
		Profile Selection			5	5
		Pedal Switch Enable off			on	on
		BDI Lockout Mode				
		BDI Lock Enable			on	on
		BDI Lock Level			10	10
		Low BDI Speed			700	700
		Low Speed Mode				
		Max Speed			2250	2250
		Reverse Speed			1000	1000
		Accel Rate			5	5
		Dccel Rate			7	7
		Brake Rate			2	2
		Profiles				
		1-Airport Mode				
		2-Golf Coastal				
		3-Gold Mid Hills				
		4-Golf Steep Hills			3000	3000
		5-Freedom Mode				
		Forward Speed			4900	5250
		Reverse Speed			1000	1000
		Accel Rate			4	4
		Decel Rate			5	5
		Brake Rate			5	5
		Drive Current Limit			100	100
	Control Mode Select				0	0
	0 - Speed Mode Express					
		Max Speed			4600	4600
		Kp			30	30
		Ki			20	20
		Accel Rate			7	7
		Decel Rate			5	5
		Brake Rate			5	5
		Pump Enable			off	off
		Regen Lower Enable			off	off
	1 - Speed Mode					
	2 - Torque Mode					
	Current Limits					
		Drive Current Limit			100	100
		Regen Current Limit			40	40
		Brake Current Limit			100	100
		EMR Current Limit			100	100
		Interlock Brake Current Limit			100	100
		Power Limiting Map				
		PL Nominal Speed			900	900
		Delta Speed			800	800
		Drive Limiting Map				
		Nominal			100	100
		Plus Delta			90	90
		Plus 2xDelta			80	80
		Plus 4xDelta			65	65
		Plus 8xDelta			52	52
		Regen Limiting Map				
		Nominal			100	100
		Plus Delta			100	100
		Plus 2xDelta			80	80
		Plus 4xDelta			50	50
		Plus 8xDelta			50	50

Throttle							
	Throttle Type					3	3
	Forward Deadband					0.75	0.75
	Forward Map					35	35
	Forward Max					4.5	4.5
	Forward Offset					0	0
	Reverse Deadband					0.75	0.75
	Reverse Map					35	35
	Reverse Max					4.5	4.5
	Reverse Offset					0	0
	Throttle Filter					2	2
	HPD SRO Type					2	2
	Sequencing Delay					0.1	0.1
	VCL Throttle Enable					Off	Off
Brake							
	Brake Pedal Enable					Off	Off
	Brake Type					5	5
	Brake Deadband					0.5	0.5
	Brake Map					50	50
	Brake Max					4.5	4.5
	Brake Offset					0	0
	Brake Filter					10	10
	VCL Brake Enable					on	on
EM Brake Control							
	Brake Type					0	0
	Pull In Voltage					100	100
	Holding Voltage					80	80
	Battery Voltage Compensated					On	On
	Set EM Brake On Fault					On	On
	Zero Speed Threshold					100	100
	Zero Speed Threshold Time					32	32
	Position Hold Setting Time					994	994
	Brake Set Time					100	100
	Torque Release Time					200	200
	Brake Release Time					50	50
	Torque Preload Delay					200	200
	Torque Preload Enable					On	On
	Torque Preload Cancel Delay					on	on
	EM Brake Fault Motor Revs					4	4
Drivers							
	Main Contactor						
	Main Enable					On	On
	Main Interlock Type					0	0
	Pull In Voltage					100	100
	Holding Voltage					100	100
	Battery Voltage Compensated					On	On
	Interlock Type					2	2
	Open Delay					0.1	0.1
	Weld Check Enable					On	On
	Main DNC Checks Enable					On	On
	Main DNC Runtime Threshold					5	5
	Precharge Enable					On	On
	Proportional Driver						
	PD Enable					Off	Off
	Hyd Lower Enable					Off	Off
	PD Max Current					2	2
	PD Min Current					0.05	0.05
	PD Dither %					0	0
	PD Dither Period					16	16
	PD Kp					10	10
	PD Ki					10	10
	Driver 3						
	Contactor Enable					off	off
	Pull Voltage					100	100
	Holding Voltage					80	80
	Fault Checking						
	Driver 1 Checks Enable					On	On
	Driver 2 Checks Enable					Off	Off
	Driver 3 Checks Enable					Off	Off
	Driver 4 Checks Enable					Off	Off
	PD Checks Enable					Off	Off
	External Supply Max					200	200
	External Supply Min					0	0
	PWM Frequency					200	200

Motor							
	Typical Max Speed					4000	4000
	Control Algorithms						
	Motor Technology					0	0
	0-ACIM (Induction Motor)						
	Characterization Tests						
	Test Enable					0	0
	Test Throttle					0	0
	Motor Poles					4	4
	Max Test Speed					2000	2000
	Max Test Current					70	70
	SplitGain					4.2	3.3
	Current Reg Tuning Test Enable					0	0
	Field Weakening Control						
	FW Base Speed					1383	1383
	Field Weakening Drive					0	0
	Weakening Rate Drive					35	35
	Min Field Current					0	0
	Swap Two Phases					off	on
	Motor Type					0	0
	LOS (Limited Operating Strategy)						
	LOS Upon Encoder Fault					on	on
	LOS Max Speed					800	800
	LOS Max Current					400	400
	LOS Max Mod Depth					50	50
	LOS Accel Rate					7	7
	LOS Decel Rate					3	3
	1-SPM (Surface PM Motor)						
	Characterization Tests						
	Test Enable					0	0
	Test Throttle					0	0
	Max Test Speed					3000	3000
	Max Test Current					20	20
	Feedback Options						
	Feedback Type					1	1
	Swap Feedback Direction					on	off
	1-Encoder						
	Encoder Step					48	64
	Encoder Fault Setup						
	Fault Detection Enable					on	on
	Encoder Pulse Fault Detect Time					0.5	0.5
	Fault Stall Time					5	5
	2-Sin/Cos						
	Sin Cos Fault Threshold					12	12
	Sin Min					0	0
	Sin Max					0	0
	Cos Min					0	0
	Cos Max					0	0
	Temperature Control						
	Sensor Enable					on	on
	Sensor Type					3	3
	Sensor Offset					0	0
	Braking Thermal Cutback Enable					off	off
	Temperature Hot					145	145
	Temperature Max					160	160
	MotorTemp LOS Max Speed					800	800
Battery							
	Nominal Voltage					48	48
	Kp UV					25	25
	Ki UV					0	0
	User Overvoltage					125	125
	User Undervoltage					70	70
	Reset Volts Per Cell					2.09	2.09
	Full Volts Per Cell					2.04	2.04
	Empty Volts Per Cell					1.75	1.75
	Discharge Time					34	34
	BDI Reset Percent					75	75
	Insulation Resistance Fault					0	0

APPENDIX 2: The troubleshooting chart for 1232SE AC controller.

Table 6 TROUBLESHOOTING CHART

CODE	PROGRAMMER LCD DISPLAY EFFECT OF FAULT	POSSIBLE CAUSE	SET/CLEAR CONDITIONS
12	Controller Overcurrent <i>ShutdownMotor;</i> <i>ShutdownMainContactor;</i> <i>ShutdownEMBrake;</i> <i>ShutdownThrottle;</i> <i>FullBrake.</i>	<ol style="list-style-type: none"> 1. External short of phase U,V, or W motor connections. 2. Motor parameters are mis-tuned. 3. Controller defective. 4. Speed encoder noise problems. 	<i>Set:</i> Phase current exceeded the current measurement limit. <i>Clear:</i> Cycle KSI.
13	Current Sensor Fault <i>ShutdownMotor;</i> <i>ShutdownMainContactor;</i> <i>ShutdownEMBrake;</i> <i>ShutdownThrottle;</i> <i>FullBrake.</i>	<ol style="list-style-type: none"> 1. Leakage to vehicle frame from phase U, V, or W (short in motor stator). 2. Controller defective. 	<i>Set:</i> Controller current sensors have invalid offset reading. <i>Clear:</i> Cycle KSI.
14	Precharge Failed <i>ShutdownMotor;</i> <i>ShutdownMainContactor;</i> <i>ShutdownEMBrake;</i> <i>ShutdownThrottle;</i> <i>FullBrake.</i>	<ol style="list-style-type: none"> 1. See Monitor menu » Battery: Capacitor Voltage. 2. External load on capacitor bank (B+ connection terminal) that prevents the capacitor bank from charging. 	<i>Set:</i> Precharge failed to charge the capacitor bank to the KSI voltage. <i>Clear:</i> Cycle Interlock input or use VCL function <i>Enable_Precharge()</i> .
15	Controller Severe Undertemp <i>ShutdownMotor;</i> <i>ShutdownMainContactor;</i> <i>ShutdownEMBrake;</i> <i>ShutdownThrottle;</i> <i>FullBrake.</i>	<ol style="list-style-type: none"> 1. See Monitor menu » Controller: Temperature. 2. Controller is operating in an extreme environment. 	<i>Set:</i> Heatsink temperature below -40°C. <i>Clear:</i> Bring heatsink temperature above -40°C, and cycle interlock or KSI.
16	Controller Severe Overtemp <i>ShutdownMotor;</i> <i>ShutdownMainContactor;</i> <i>ShutdownEMBrake;</i> <i>ShutdownThrottle;</i> <i>FullBrake.</i>	<ol style="list-style-type: none"> 1. See Monitor menu » Controller: Temperature. 2. Controller is operating in an extreme environment. 3. Excessive load on vehicle. 	<i>Set:</i> Heatsink temperature above +95°C. <i>Clear:</i> Bring heatsink temperature below +95°C, and cycle interlock or KSI.
17	Severe B+ Undervoltage <i>Reduced drive torque.</i>	<ol style="list-style-type: none"> 1. Battery Menu parameters are misadjusted. 2. Non-controller system drain on battery. 3. Battery resistance too high. 4. Battery disconnected while driving. 5. See Monitor menu » Battery: Capacitor Voltage. 6. Blown B+ fuse or main contactor did not close. 	<i>Set:</i> Capacitor bank voltage dropped below the Severe Undervoltage limit (see page 64) with FET bridge enabled. <i>Clear:</i> Bring capacitor voltage above Severe Undervoltage limit.
17	Severe KSI Undervoltage <i>If below brownout voltage, motor current is switched off and reset may occur.</i>	<ol style="list-style-type: none"> 1. See Monitor menu » Battery: Keyswitch Voltage. 2. Non-controller system drain on low power circuit voltage. 3. Resistance in low power circuit too high. 4. Low power circuit power source disconnected while driving. 5. Blown fuse. 	<i>Set:</i> KSI voltage dropped below 8.4 V (Brownout occurs at 8.0 V.) <i>Clear:</i> Bring KSI voltage above 8.4 V.

Table 6 TROUBLESHOOTING CHART, cont'd

CODE	PROGRAMMER LCD DISPLAY EFFECT OF FAULT	POSSIBLE CAUSE	SET/CLEAR CONDITIONS
18	Severe B+ Overvoltage <i>ShutdownMotor;</i> <i>ShutdownMainContactor;</i> <i>ShutdownEMBrake;</i> <i>ShutdownThrottle;</i> <i>FullBrake.</i>	<ol style="list-style-type: none"> 1. See Monitor menu » Battery: Capacitor Voltage. 2. Battery menu parameters are misadjusted. 3. Battery resistance too high for given regen current. 4. Battery disconnected while regen braking. 	<p><i>Set:</i> Capacitor bank voltage exceeded the Severe Overvoltage limit (see page 64) with FET bridge enabled.</p> <p><i>Clear:</i> Bring capacitor voltage below Severe Overvoltage limit, and then</p>
22	Controller Overtemp Cutback <i>Reduced drive and brake torque.</i>	<ol style="list-style-type: none"> 1. See Monitor menu » Controller: Temperature. 2. Controller is performance-limited at this temperature. 3. Controller is operating in an extreme environment. 4. Excessive load on vehicle. 5. Improper mounting of controller. 	<p><i>Set:</i> Heatsink temperature exceeded 85°C.</p> <p><i>Clear:</i> Bring heatsink temperature below 85°C.</p>
23	B+ Undervoltage Cutback <i>Reduced drive torque.</i>	<ol style="list-style-type: none"> 1. Normal operation. Fault shows that the batteries need recharging. Controller is performance limited at this voltage. 2. Battery parameters are misadjusted. 3. Non-controller system drain on battery. 4. Battery resistance too high. 5. Battery disconnected while driving. 6. See Monitor menu » Battery: Capacitor Voltage. 7. Blown B+ fuse or main contactor did not close. 	<p><i>Set:</i> Capacitor bank voltage dropped below the Undervoltage limit (see page 64) with the FET bridge enabled.</p> <p><i>Clear:</i> Bring capacitor voltage above the Undervoltage limit.</p>
24	B+ Overvoltage Cutback <i>Reduced brake torque.</i> <i>Note: This fault is declared only when the controller is running in regen.</i>	<ol style="list-style-type: none"> 1. Normal operation. Fault shows that regen braking currents elevated the battery voltage during regen braking. Controller is performance limited at this voltage. 2. Battery parameters are misadjusted. 3. Battery resistance too high for given regen current. 4. Battery disconnected while regen braking. 5. See Monitor menu » Battery: Capacitor Voltage. 	<p><i>Set:</i> Capacitor bank voltage exceeded the Overvoltage limit (see page 64) with the FET bridge enabled.</p> <p><i>Clear:</i> Bring capacitor voltage below the Overvoltage limit.</p>
25	+5V Supply Failure <i>None, unless a fault action is programmed in VCL.</i>	<ol style="list-style-type: none"> 1. External load impedance on the +5V supply (pin 26) is too low. 2. See Monitor menu » outputs: 5 Volts and Ext Supply Current. 	<p><i>Set:</i> +5V supply (pin 26) outside the +5V±10% range.</p> <p><i>Clear:</i> Bring voltage within range.</p>
26	Digital Out 6 Open/Short <i>Digital Output 6 driver will not turn on.</i>	<ol style="list-style-type: none"> 1. External load impedance on Digital Output 6 driver (pin 19) is too low. 	<p><i>Set:</i> Digital Output 6 (pin 19) current exceeded 15 mA.</p> <p><i>Clear:</i> Remedy the overcurrent cause and use the VCL function <i>Set</i> to turn the driver on again.</p>

Table 6 TROUBLESHOOTING CHART, cont'd

CODE	PROGRAMMER LCD DISPLAY EFFECT OF FAULT	POSSIBLE CAUSE	SET/CLEAR CONDITIONS
27	Digital Out 7 Open/Short <i>Digital Output 7 driver will not turn on.</i>	1. External load impedance on Digital Output 7 driver (pin 20) is too low.	<i>Set:</i> Digital Output 7 (pin 20) current exceeded 15 mA. <i>Clear:</i> Remedy the overcurrent cause and use the VCL function <i>Set_DigOut()</i> to turn the driver on again.
28	Motor Temp Hot Cutback <i>Reduced drive torque.</i>	1. Motor temperature is at or above the programmed Temperature Hot setting, and the current is being cut back. 2. Motor Temperature Control Menu parameters are mis-tuned. 3. See Monitor menu » Motor: Temperature and » Inputs: Analog2. 4. If the application doesn't use a motor thermistor, Temp Compensation and Temp Cutback should be programmed Off.	<i>Set:</i> Motor temperature is at or above the Temperature Hot parameter setting. <i>Clear:</i> Bring the motor temperature within range.
29	Motor Temp Sensor Fault <i>Max.Speed reduced (LOS, Limited Operating Strategy), and motor temperature cutback disabled.</i>	1. Motor thermistor is not connected properly. 2. If the application doesn't use a motor thermistor, Motor Temp Sensor Enable should be programmed Off. 3. See Monitor menu » Motor: Temperature and » Inputs: Analog2.	<i>Set:</i> Motor thermistor input (pin 8) is at the voltage rail (0 or 10V). <i>Clear:</i> Bring the motor thermistor input voltage within range.
31	Coil1 Driver Open/Short <i>ShutdownDriver1.</i>	1. Open or short on driver load. 2. Dirty connector pins. 3. Bad crimps or faulty wiring.	<i>Set:</i> Driver 1 (pin 6) is either open or shorted. This fault can be set only when Main Enable = Off. <i>Clear:</i> Correct open or short, and cycle driver.
31	Main Open/Short <i>ShutdownMotor; ShutdownMainContactor; ShutdownEMBrake; ShutdownThrottle; FullBrake.</i>	1. Open or short on driver load. 2. Dirty connector pins. 3. Bad crimps or faulty wiring.	<i>Set:</i> Main contactor driver (pin 6) is either open or shorted. This fault can be set only when Main Enable = On. <i>Clear:</i> Correct open or short, and cycle driver
32	Coil2 Driver Open/Short <i>ShutdownDriver2.</i>	1. Open or short on driver load. 2. Dirty connector pins. 3. Bad crimps or faulty wiring.	<i>Set:</i> Driver 2 (pin 5) is either open or shorted. This fault can be set only when EM Brake Type = 0. <i>Clear:</i> Correct open or short, and cycle driver.
32	EMBrake Open/Short <i>ShutdownEMBrake; ShutdownThrottle; FullBrake.</i>	1. Open or short on driver load. 2. Dirty connector pins. 3. Bad crimps or faulty wiring.	<i>Set:</i> Electromagnetic brake driver (pin 5) is either open or shorted. This fault can be set only when EM Brake Type >0. <i>Clear:</i> Correct open or short, and cycle driver.
33	Coil3 Driver Open/Short <i>ShutdownDriver3.</i>	1. Open or short on driver load. 2. Dirty connector pins. 3. Bad crimps or faulty wiring.	<i>Set:</i> Driver 3 (pin 4) is either open or shorted. <i>Clear:</i> Correct open or short, and cycle driver.
34	Coil4 Driver Open/Short <i>ShutdownDriver4.</i>	1. Open or short on driver load. 2. Dirty connector pins. 3. Bad crimps or faulty wiring.	<i>Set:</i> Driver 4 (pin 3) is either open or shorted. <i>Clear:</i> Correct open or short, and

Table 6 TROUBLESHOOTING CHART, cont'd

CODE	PROGRAMMER LCD DISPLAY EFFECT OF FAULT	POSSIBLE CAUSE	SET/CLEAR CONDITION
35	PD Open/Short <i>ShutdownPD.</i>	1. Open or short on driver load. 2. Dirty connector pins. 3. Bad crimps or faulty wiring.	<i>Set:</i> Proportional driver (pin 2) is either open or shorted. <i>Clear:</i> Correct open or short, and cycle driver.
36	Encoder Fault <i>ShutdownEMBrake;</i> <i>ShutdownThrottle.</i>	1. Motor encoder failure. 2. Bad crimps or faulty wiring. 3. See Monitor menu » Motor: Motor RPM.	<i>Set:</i> Motor encoder phase failure detected. <i>Clear:</i> Cycle KSI.
36	Sin/Cos Sensor Fault <i>ShutdownEMBrake;</i> <i>ShutdownThrottle.</i>	1. Sin/cos sensor failure. 2. Bad crimps or faulty wiring. 3. See Monitor menu » Motor: Motor RPM.	<i>Set:</i> Motor Sin/Cos sensor failure detected. <i>Clear:</i> Cycle KSI.
37	Motor Open <i>ShutdownMotor;</i> <i>ShutdownMainContactor;</i> <i>ShutdownEMBrake;</i> <i>ShutdownThrottle;</i> <i>FullBrake.</i>	1. Motor phase is open. 2. Bad crimps or faulty wiring.	<i>Set:</i> Motor phase U, V, or W detected open. <i>Clear:</i> Cycle KSI.
38	Main Contactor Welded <i>ShutdownMotor;</i> <i>ShutdownMainContactor;</i> <i>ShutdownEMBrake;</i> <i>ShutdownThrottle;</i> <i>FullBrake.</i>	1. Main contactor tips are welded closed. 2. Motor phase U or V is disconnected or open. 3. An alternate voltage path (such as an external precharge resistor) is providing a current to the capacitor bank (B+ connection terminal).	<i>Set:</i> Just prior to the main contactor closing, the capacitor bank voltage (B+ connection terminal) was loaded for a short time and the voltage did not discharge. <i>Clear:</i> Cycle KSI
39	Main Contactor Did Not Close <i>ShutdownMotor;</i> <i>ShutdownMainContactor;</i> <i>ShutdownEMBrake;</i> <i>ShutdownThrottle;</i> <i>FullBrake.</i>	1. Main contactor did not close. 2. Main contactor tips are oxidized, burned, or not making good contact. 3. External load on capacitor bank (B+ connection terminal) that prevents capacitor bank from charging. 4. Blown B+ fuse.	<i>Set:</i> With the main contactor commanded closed, the capacitor bank voltage (B+ connection terminal) did not charge to B+. <i>Clear:</i> Cycle KSI.
41	Throttle Wiper High <i>ShutdownThrottle.</i>	1. See Monitor menu » Inputs: Throttle Pot. 2. Throttle pot wiper voltage too high.	<i>Set:</i> Throttle pot wiper (pin 16) voltage is higher than the high fault threshold (can be changed with the VCL function <i>Setup_Pot_Faults()</i>). <i>Clear:</i> Bring throttle pot wiper voltage below the fault threshold.
42	Throttle Wiper Low <i>ShutdownThrottle.</i>	1. See Monitor menu » Inputs: Throttle Pot. 2. Throttle pot wiper voltage too low.	<i>Set:</i> Throttle pot wiper (pin 16) voltage is lower than the low fault threshold (can be changed with the VCL function <i>Setup_Pot_Faults()</i>). <i>Clear:</i> Bring throttle pot wiper voltage above the fault threshold.

Table 6 TROUBLESHOOTING CHART, cont'd

CODE	PROGRAMMER LCD DISPLAY EFFECT OF FAULT	POSSIBLE CAUSE	SET/CLEAR CONDITIONS
43	Pot2 Wiper High <i>FullBrake.</i>	<ol style="list-style-type: none"> 1. See Monitor menu » Inputs: Pot2 Raw. 2. Pot2 wiper voltage too high. 	<p><i>Set:</i> Pot2 wiper (pin 17) voltage is higher than the high fault threshold (can be changed with the VCL function <i>Setup_Pot_Faults()</i>).</p> <p><i>Clear:</i> Bring Pot2 wiper voltage below the fault threshold.</p>
44	Pot2 Wiper Low <i>FullBrake.</i>	<ol style="list-style-type: none"> 1. See Monitor menu » Inputs: Pot2 Raw. 2. Pot2 wiper voltage too low. 	<p><i>Set:</i> Pot2 wiper (pin 17) voltage is lower than the low fault threshold (can be changed with the VCL function <i>Setup_Pot_Faults()</i>).</p> <p><i>Clear:</i> Bring Pot2 wiper voltage above the fault threshold.</p>
45	Pot Low OverCurrent <i>ShutdownThrottle;</i> <i>FullBrake.</i>	<ol style="list-style-type: none"> 1. See Monitor menu » Outputs: Pot Low. 2. Combined pot resistance connected to pot low is too low. 	<p><i>Set:</i> Pot low (pin 18) current exceeds 10mA.</p> <p><i>Clear:</i> Clear pot low overcurrent condition and cycle KSI.</p>
46	EEPROM Failure <i>ShutdownMotor;</i> <i>ShutdownMainContactor;</i> <i>ShutdownEMBrake;</i> <i>ShutdownThrottle;</i> <i>ShutdownInterlock;</i> <i>ShutdownDriver1;</i> <i>ShutdownDriver2;</i> <i>ShutdownDriver3;</i> <i>ShutdownDriver4;</i> <i>ShutdownPD;</i> <i>FullBrake.</i>	<ol style="list-style-type: none"> 1. Failure to write to EEPROM memory. This can be caused by EEPROM memory writes initiated by VCL, by the CAN bus, by adjusting parameters with the programmer, or by loading new software into the controller. 	<p><i>Set:</i> Controller operating system tried to write to EEPROM memory and failed.</p> <p><i>Clear:</i> Download the correct software (OS) and matching parameter default settings into the controller and cycle KSI.</p>
47	HPD/Sequencing Fault <i>ShutdownThrottle.</i>	<ol style="list-style-type: none"> 1. KSI, interlock, direction, and throttle inputs applied in incorrect sequence. 2. Faulty wiring, crimps, or switches at KSI, interlock, direction, or throttle inputs. 3. See Monitor menu » Inputs. 	<p><i>Set:</i> HPD (High Pedal Disable) or sequencing fault caused by incorrect sequence of KSI, interlock, direction, and throttle inputs.</p> <p><i>Clear:</i> Reapply inputs in correct sequence.</p>
47	Emer Rev HPD <i>ShutdownThrottle;</i> <i>ShutdownEMBrake.</i>	<ol style="list-style-type: none"> 1. Emergency Reverse operation has concluded, but the throttle, forward and reverse inputs, and interlock have not been returned to neutral. 	<p><i>Set:</i> At the conclusion of Emergency Reverse, the fault was set because various inputs were not returned to neutral.</p> <p><i>Clear:</i> If EMR_Interlock = On, clear the interlock, throttle, and direction inputs. If EMR_Interlock = Off, clear the throttle and direction inputs.</p>
48	Following Error Fault <i>ShutdownMotor;</i> <i>ShutdownMainContactor;</i> <i>ShutdownEMBrake;</i> <i>ShutdownThrottle;</i> <i>ShutdownInterlock;</i> <i>ShutdownDriver1;</i> <i>ShutdownDriver2;</i> <i>ShutdownDriver3;</i> <i>ShutdownDriver4;</i> <i>ShutdownPD;</i> <i>FullBrake.</i>	<ol style="list-style-type: none"> 1. The Following Error Limit has been exceeded for the Following Error Time. 2. Incorrect or overly restrictive Following Error Limit and Following Error Time parameter settings. 3. Motor or drivetrain rotation obstruction or degradation. 	<p><i>Set:</i> The Following Error Limit has been exceeded for the Following Error Time.</p> <p><i>Clear:</i> Cycle KSI.</p>

Table 6 TROUBLESHOOTING CHART, cont'd

CODE	PROGRAMMER LCD DISPLAY EFFECT OF FAULT	POSSIBLE CAUSE	SET/CLEAR CONDITIONS
49	Parameter Change Fault <i>ShutdownMotor;</i> <i>ShutdownMainContactor;</i> <i>ShutdownEMBrake;</i> <i>ShutdownThrottle;</i> <i>FullBrake.</i>	1. This is a safety fault caused by a change in certain parameter settings so that the vehicle will not operate until KSI is cycled. For example, if a user changes the Throttle Type this fault will appear and require cycling KSI before the vehicle can operate.	<i>Set:</i> Adjustment of a parameter setting that requires cycling of KSI. <i>Clear:</i> Cycle KSI.
51–67	OEM Faults <i>(See OEM documentation.)</i>	1. These faults can be defined by the OEM and are implemented in the application-specific VCL code. See OEM documentation.	<i>Set:</i> See OEM documentation. <i>Clear:</i> See OEM documentation.
68	VCL Run Time Error <i>ShutdownMotor;</i> <i>ShutdownMainContactor;</i> <i>ShutdownEMBrake;</i> <i>ShutdownThrottle;</i> <i>ShutdownInterlock;</i> <i>ShutdownDriver1;</i> <i>ShutdownDriver2;</i> <i>ShutdownDriver3;</i> <i>ShutdownDriver4;</i> <i>ShutdownPD;</i> <i>FullBrake.</i>	1. VCL code encountered a runtime VCL error. 2. See Monitor menu » Controller: VCL Error Module and VCL Error. This error can then be compared to the runtime VCL module ID and error code definitions found in the specific OS system information file.	<i>Set:</i> Runtime VCL code error condition. <i>Clear:</i> Edit VCL application software to fix this error condition; flash the new compiled software and matching parameter defaults; cycle KSI.
69	External Supply Out of Range <i>None, unless a fault action is programmed in VCL.</i>	1. External load on the 5V and 12V supplies draws either too much or too little current. 2. Fault Checking Menu parameters Ext Supply Max and Ext Supply Min are mis-tuned. 3. See Monitor menu » Outputs: Ext Supply Current.	<i>Set:</i> The external supply current (combined current used by the 5V supply [pin 26] and 12V supply [pin 25]) is either greater than the upper current threshold or lower than the lower current threshold. The two thresholds are defined by the External Supply Max and External Supply Min parameter settings (page 54). <i>Clear:</i> Bring the external supply current within range.
71	OS General <i>ShutdownMotor;</i> <i>ShutdownMainContactor;</i> <i>ShutdownEMBrake;</i> <i>ShutdownThrottle;</i> <i>ShutdownInterlock;</i> <i>ShutdownDriver1;</i> <i>ShutdownDriver2;</i> <i>ShutdownDriver3;</i> <i>ShutdownDriver4;</i> <i>ShutdownPD;</i> <i>FullBrake.</i>	1. Internal controller fault.	<i>Set:</i> Internal controller fault detected. <i>Clear:</i> Cycle KSI.
72	PDO Timeout <i>ShutdownThrottle;</i> <i>CAN NMT State set to Pre-operational.</i>	1. Time between CAN PDO messages received exceeded the PDO Timeout Period.	<i>Set:</i> Time between CAN PDO messages received exceeded the PDO Timeout Period. <i>Clear:</i> Cycle KSI or receive CAN NMT message.

Table 6 TROUBLESHOOTING CHART, cont'd

CODE	PROGRAMMER LCD DISPLAY EFFECT OF FAULT	POSSIBLE CAUSE	SET/CLEAR CONDITIONS
73	Stall Detected <i>ShutdownEMBrake;</i> <i>ShutdownThrottle;</i> <i>Control Mode changed to LOS (Limited Operating Strategy).</i>	<ol style="list-style-type: none"> 1. Stalled motor. 2. Motor encoder failure. 3. Bad crimps or faulty wiring. 4. Problems with power supply for the motor encoder. 5. See Monitor menu » Motor: Motor RPM. 	<i>Set:</i> No motor encoder movement detected. <i>Clear:</i> Either cycle KSI, or detect valid motor encoder signals while operating in LOS mode and return Throttle Command = 0 and Motor RPM = 0.
74	Fault On Other Traction Controller	Dual Drive fault: see Dual Drive manual.	
75	Dual Severe Fault	Dual Drive fault: see Dual Drive manual.	
77	Supervisor Fault <i>ShutdownMotor;</i> <i>ShutdownMainContactor;</i> <i>ShutdownEMBrake;</i> <i>ShutdownThrottle;</i> <i>ShutdownInterlock;</i> <i>ShutdownDriver1;</i> <i>ShutdownDriver2;</i> <i>ShutdownDriver3;</i> <i>ShutdownDriver4;</i> <i>ShutdownPD;</i> <i>FullBrake.</i>	<ol style="list-style-type: none"> 1. The Supervisor has detected a mismatch in redundant readings. 2. Internal damage to Supervisor microprocessor. 3. Switch inputs allowed to be within upper and lower thresholds for over 100 milliseconds. 	<i>Set:</i> Mismatched redundant readings; damaged Supervisor; illegal switch inputs. <i>Clear:</i> Check for noise or voltage drift in all switch inputs; check connections; cycle KSI.
78	Supervisor Incompatible <i>ShutdownMotor;</i> <i>ShutdownMainContactor;</i> <i>ShutdownEMBrake;</i> <i>ShutdownThrottle;</i> <i>ShutdownInterlock;</i> <i>ShutdownDriver1;</i> <i>ShutdownDriver2;</i> <i>ShutdownDriver3;</i> <i>ShutdownDriver4;</i> <i>ShutdownPD;</i> <i>FullBrake.</i>	<ol style="list-style-type: none"> 1. The main OS is not compatible with the Supervisor OS. 	<i>Set:</i> Incompatible software. <i>Clear:</i> Load properly matched OS code or update the Supervisor code; cycle KSI.
82	Bad Calibrations <i>ShutdownMotor;</i> <i>ShutdownMainContactor;</i> <i>ShutdownEMBrake;</i> <i>ShutdownThrottle;</i> <i>FullBrake.</i>	<ol style="list-style-type: none"> 1. Internal controller fault. 	<i>Set:</i> Internal controller fault detection. <i>Clear:</i> Cycle KSI.
83	Driver Supply <i>ShutdownMotor;</i> <i>ShutdownMainContactor;</i> <i>ShutdownEMBrake;</i> <i>ShutdownThrottle;</i> <i>FullBrake.</i>	<ol style="list-style-type: none"> 1. Internal controller fault in the voltage supply for the driver circuits. 	<i>Set:</i> Internal controller fault detection. <i>Clear:</i> Cycle KSI.

Table 6 TROUBLESHOOTING CHART, cont'd

CODE	PROGRAMMER LCD DISPLAY EFFECT OF FAULT	POSSIBLE CAUSE	SET/CLEAR CONDITIONS
87	Motor Characterization Fault <i>ShutdownMotor;</i> <i>ShutdownMainContactor;</i> <i>ShutdownEMBrake;</i> <i>ShutdownThrottle;</i> <i>FullBrake.</i>	1. Motor characterization failed during characterization process. See Monitor menu » Controller: Motor Characterization Error for cause: 0=none 1=encoder signal seen, but step size not determined; set Encoder Step Size manually 2=motor temp sensor fault 3=motor temp hot cutback fault 4= controller overtemp cutback fault 5=controller undertemp cutback fault 6=undervoltage cutback fault 7=severe overvoltage fault 8=encoder signal not seen, or one or both channels missing 9=motor parameters out of characterization range.	<i>Set:</i> Motor characterization failed during the motor characterization process. <i>Clear:</i> Correct fault; cycle KSI.
88	Encoder Pulse Count Fault <i>ShutdownMotor;</i> <i>ShutdownMainContactor;</i> <i>ShutdownEMBrake;</i> <i>ShutdownThrottle;</i> <i>ShutdownInterlock;</i> <i>ShutdownDriver1;</i> <i>ShutdownDriver2;</i> <i>ShutdownDriver3;</i> <i>ShutdownDriver4;</i> <i>ShutdownPD;</i> <i>FullBrake.</i>	1. Encoder Steps parameter does not match the actual motor encoder.	<i>Set:</i> Motor lost IFO control and accelerated without throttle command. <i>Clear:</i> Ensure the Encoder Steps parameter matches the actual encoder; cycle KSI.
89	Motor Type Fault <i>ShutdownMotor;</i> <i>ShutdownMainContactor;</i> <i>ShutdownEMBrake;</i> <i>ShutdownThrottle;</i> <i>FullBrake.</i>	1. The Motor_Type parameter value is out of range.	<i>Set:</i> Motor_Type parameter is set to an illegal value. <i>Clear:</i> Set Motor_Type to correct value and cycle KSI.
91	VCL/OS Mismatch <i>ShutdownMotor;</i> <i>ShutdownMainContactor;</i> <i>ShutdownEMBrake;</i> <i>ShutdownThrottle;</i> <i>ShutdownInterlock;</i> <i>ShutdownDriver1;</i> <i>ShutdownDriver2;</i> <i>ShutdownDriver3;</i> <i>ShutdownDriver4;</i> <i>ShutdownPD;</i> <i>FullBrake.</i>	1. The VCL software in the controller does not match the OS software in the controller.	<i>Set:</i> VCL and OS software do not match; when KSI cycles, a check is made to verify that they match and a fault is issued when they do not. <i>Clear:</i> Download the correct VCL and OS software into the controller.

Table 6 TROUBLESHOOTING CHART, cont'd

CODE	PROGRAMMER LCD DISPLAY <i>EFFECT OF FAULT</i>	POSSIBLE CAUSE	SET/CLEAR CONDITIONS
92	EM Brake Failed to Set <i>ShutdownEMBrake;</i> <i>ShutdownThrottle.</i> <i>Position Hold is engaged when Interlock=On.</i>	<ol style="list-style-type: none"> 1. Vehicle movement sensed after the EM Brake has been commanded to set. 2. EM Brake will not hold the motor from rotating. 	<p><i>Set:</i> After the EM Brake was commanded to set and time has elapsed to allow the brake to fully engage, vehicle movement has been sensed.</p> <p><i>Clear:</i> Activate the throttle.</p>
93	Encoder LOS (Limited Operating Strategy) <i>Enter LOS control mode.</i>	<ol style="list-style-type: none"> 1. Limited Operating Strategy (LOS) control mode has been activated, as a result of either an Encoder Fault (Code 36) or a Stall Detect Fault (Code 73). 2. Motor encoder failure. 3. Bad crimps or faulty wiring. 4. Vehicle is stalled. 	<p><i>Set:</i> Encoder Fault (Code 36) or Stall Detect Fault (Code 73) was activated, and Brake or Interlock has been applied to activate LOS control mode, allowing limited motor control.</p> <p><i>Clear:</i> Cycle KSI or, if LOS mode was activated by the Stall Fault, clear by ensuring encoder senses proper operation, Motor RPM = 0, and Throttle Command = 0.</p>
94	EMR Rev Timeout <i>ShutdownEMBrake;</i> <i>ShutdownThrottle.</i>	<ol style="list-style-type: none"> 1. Emergency Reverse was activated and concluded because the EMR Timeout timer has expired. 2. The emergency reverse input is stuck On. 	<p><i>Set:</i> Emergency Reverse was activated and ran until the EMR Timeout timer expired.</p> <p><i>Clear:</i> Turn the emergency reverse input Off.</p>
98	Illegal Model Number <i>ShutdownMotor;</i> <i>ShutdownMainContactor;</i> <i>ShutdownEMBrake;</i> <i>ShutdownThrottle;</i> <i>FullBrake.</i>	<ol style="list-style-type: none"> 1. Model_Number variable contains illegal value. 2. Software and hardware do not match. 3. Controller defective. 	<p><i>Set:</i> Illegal Model_Number variable; when KSI cycles, a check is made to confirm a legal Model_Number, and a fault is issued if one is not found.</p> <p><i>Clear:</i> Download appropriate software for your controller model.</p>
99	Parameter Mismatch <i>ShutdownMotor;</i> <i>ShutdownMainContactor;</i> <i>ShutdownEMBrake;</i> <i>ShutdownThrottle;</i> <i>FullBrake.</i>	<ol style="list-style-type: none"> 1. Dual Motor Enable parameter is set On and Control Mode Select parameter not set to 1 (Speed Mode Express) or 2 (Speed Mode). 2. Motor Technology and Feedback Type parameters do not match. 	<p><i>Set:</i> When the Dual Drive software is enabled, the controller must be set to either Speed Mode Express or Speed Mode; otherwise this fault is set.</p> <p>Motor Technology=0 must be paired with Feedback Type=1, and Motor Technology=1 must be paired with Feedback Type=2; otherwise this fault is set.</p> <p><i>Clear:</i> Adjust parameters to appropriate values and cycle KSI.</p>