



**2000
DS Golf Car
Gasoline**

Owner's Manual

EMISSION CONTROL INFORMATION

Fuel Information

THIS VEHICLE IS CERTIFIED TO OPERATE ON UNLEADED REGULAR GRADE GASOLINE ONLY. A minimum of 87 octane of the anti-knock index is recommended. The anti-knock index is posted on service station pumps in the U.S.A.

Emission Control Information

To protect the environment in which we all live, Club Car has incorporated crankcase emission (1) and exhaust emission (2) control systems (EM) in compliance with applicable regulations of the U.S. Environmental Protection Agency and California Air Resources Board.

1. Crankcase Emission Control System

A sealed-type crankcase emission control system is used to eliminate blow-by gases. The blow-by gases are led to the breather chamber through the crankcase. Then, it is led to the air cleaner.

Oil is separated from the gases while passing through the inside of the breather chamber from the crankcase, and then returned back to the bottom of the crankcase.

2. Exhaust Emission Control System

The exhaust emission control system applied to this engine consists of a carburetor and an ignition system having optimum ignition timing characteristics.

The carburetors have been calibrated to provide lean air/fuel mixture characteristics and optimum fuel economy with a suitable air cleaner and exhaust system.

Maintenance and Warranty

Proper maintenance is necessary to ensure that your engine will continue to have low emission levels. Those items identified by the Periodic Maintenance Chart are necessary to ensure compliance with the applicable standards.

The Club Car Limited Emission Control System Warranty requires that you return your engine to an authorized Club Car Dealer for remedy under warranty. Please read the warranty carefully, and keep it valid by complying with the owner's obligations it contains.

Tampering with Emission Control System Prohibited

California State law prohibits the following

acts or the causing thereof: (1) the removal or rendering inoperative by any person other than for purposes of maintenance, repair, or replacement, of any device or element of design incorporated into any new engine for the purposes of emission control prior to its sale or delivery to the ultimate purchaser or while it is in use, or (2) the use of the engine after such device or element of design has been removed or rendered inoperative by any person.

Among those acts presumed to constitute tampering are the acts listed below:

Do not tamper with the original emission related parts:

- Carburetor and internal parts
- Spark plugs
- Magneto or electronic ignition system
- Fuel filter element
- Air cleaner element
- Crankcase
- Cylinder head
- Breather chamber and internal parts
- Intake pipe and tube

FUEL AND OIL RECOMMENDATIONS

Fuel

Use only clean, fresh, unleaded regular grade gasoline.

Octane Rating

The octane rating of a gasoline is a measure of its resistance to "knocking". Use of a minimum of 87 octane of the anti-knock index is recommended. The anti-knock index is posted on service station pumps in the U.S.A.

NOTE

- If "knocking or pinging" occurs, use a different brand of gasoline or higher octane rating.

CAUTION

- Do not mix oil with gasoline.

Oxygenated Fuel

If you use oxygenated fuel (either ethanol or MTBE added to gasoline), be sure it is unleaded and meets the minimum octane rating requirement.

The following are the EPA approved percentages of fuel oxygenates.

ETHANOL: (Ethyl or Grain Alcohol) You may use gasoline containing up to 10% ethanol by volume.

MTBE: (Methyl Tertiary Butyl Ether) You may use gasoline containing up to 15% MTBE by volume.

METHANOL: (Methanol or Wood Alcohol) 5% by volume.

You may use gasoline containing up to 5% methanol by volume, as long as it also contains cosolvents and corrosion inhibitors to protect the fuel system. Gasoline containing more than 5% methanol by volume may cause starting and/or performance problems. It may also damage metal, rubber, and plastic parts of your fuel system.

WARNING

- Gasoline is extremely flammable and can be explosive under certain conditions. Turn the engine switch OFF. Do not smoke. Make sure the area is well ventilated and free from any source of flame or sparks; this includes any appliance with a pilot light. Never fill the tank so the fuel level rises into the filler neck. If the tank is overfilled, heat may cause the fuel to expand and overflow through the vents in the tank cap.

Engine Oil

The following engine oils are recommended. API Service Classification: SC, SD, SE, SF, SG, or SH.

WARNING

- After refueling, make sure the tank cap is closed securely.
- If gasoline is spilled on the fuel tank wipe it off immediately.

Oil Viscosity

Choose the viscosity according to the temperature as follows:

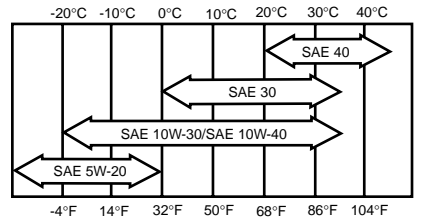

NOTE

- Using multi-grade oils (5W-20, 10W-30, and 10W-40) will increase oil consumption. Check oil level more frequently when using them.

WARNING

- THE ENGINE EXHAUST FROM THIS PRODUCT CONTAINS CHEMICALS KNOWN TO THE STATE OF CALIFORNIA TO CAUSE CANCER, BIRTH DEFECTS, OR OTHER REPRODUCTIVE HARM.

NOTICE

The Club Car Limited Warranty for owners of single golf cars appears on the pages following this notice, and the Limited Lifetime Fleet Warranty appears on the last pages of this manual. No other warranties, express or implied, are contained herein. Your authorized representative checked this vehicle before it was delivered to you and will provide a completed warranty registration card to you.

Club Car is not liable for errors in this manual or for incidental or consequential damages that result from the use of the material in this manual.

This vehicle conforms to the current American National Standards Institute's Z130 Safety and Performance Requirements for Golf Cars. This standard, which promotes safety in the design, application, and operation of golf cars, defines a golf car as "a vehicle used to convey a person or persons and equipment to play the game of golf in an area designated as a golf course." Throughout this manual, the words "golf car" and "vehicle" are used interchangeably.

This manual contains proprietary information that is protected by copyright. All rights are reserved. No part of this manual may be photocopied, reproduced, or translated to another language without the written consent of Club Car, Inc.

The information contained in this document is subject to change without notice.

Club Car reserves the right to make design changes to vehicles without obligation to make these changes on units previously sold.

These vehicles do not conform to Federal Motor Vehicle Safety Standards for automobiles or to FMVSS 500 for low-speed vehicles, and are not equipped for operation on public streets, roads, or highways.



**P.O. Box 204658
Augusta, Georgia 30917-4658 USA
Telephone: 1-800-ClubCar (258-2227)
www.clubcar.com**

©1999 Club Car, Inc.

Club Car, *Armorflex*, and *Tranquility* are registered trademarks of Club Car, Inc.

This manual effective July 26, 1999

CLUB CAR LIMITED THREE YEAR WARRANTY FOR 2000 SINGLE GOLF CARS

1. WARRANTY:

CLUB CAR, INC., ("CLUB CAR") hereby warrants to the original retail purchaser that its new 2000 Model DS golf car purchased from CLUB CAR or an authorized distributor or dealer for use in the United States or Canada shall be free from defects in materials and workmanship under normal use and service as a golf car for the periods stated below, subject to the provisions, limitations, and exclusions contained in this limited warranty.

LIMITED THREE YEAR WARRANTY:

The golf car frame (excluding the front and rear bumper mounts), rack and pinion steering gearbox unit, suspension system (defined as the shock absorbers, shock mounts, A-plate, leaf springs, shackles, and associated hardware), gasoline engine, unitized transaxle, torque converters (drive and driven), starter generator, transaxle (electric vehicle), and electric motor are warranted with respect to parts and labor against defects in materials and workmanship for a period of three years from the date of purchase.

LIMITED TWO YEAR WARRANTY:

All remaining components of the golf car not specified otherwise, except options and accessories, are warranted with respect to parts and labor against defects in materials and workmanship for a period of two years from the date of purchase.

LIMITED ONE YEAR WARRANTY:

All original equipment options and accessories supplied by Club Car are warranted with respect to parts and labor against defects in material and workmanship for a period of one year from the date of purchase.

This limited warranty covers materials, workmanship, and repair labor cost as to those items specifically listed above for the periods specified. Such repair labor shall be performed only by CLUB CAR, its authorized distributors or dealers, or a service agency approved by CLUB CAR.

IF THE WARRANTY REGISTRATION FORM IS NOT COMPLETED AND RETURNED TO CLUB CAR AT THE TIME OF THE ORIGINAL RETAIL SALE, PURCHASER MUST PROVIDE PROOF OF DATE OF PURCHASE WITH ANY WARRANTY CLAIM.

2. EXCLUSIONS:

Excluded from any CLUB CAR warranty are all fuses, filters, decals (except safety decals), spark plugs, lubricants, trim pieces, seats, routine wear items such as the charger plug and receptacle, brake shoes, belts, brushes, bushings, engine mounts, mats and pads, maintenance adjustments, cosmetic deterioration, and items which deteriorate or fail due to exposure or ordinary wear and tear. Batteries, battery charger, onboard computer, and solid state controller are covered by separate CLUB CAR warranties. Tires are warranted by their manufacturer. Also excluded from any CLUB CAR warranty is damage to a golf car or component resulting from a cause other than a defect including unreasonable or unintended strain or use, improper installation of accessories, installation of parts or accessories that are not original equipment, overloading, accident, alteration, abuse, or neglect.

Transportation expenses for warranty service are also excluded from this warranty.

3. VOIDING OF WARRANTY:

THIS AND ANY OTHER WARRANTY SHALL BE VOID IF THE GOLF CAR IS ABUSED OR USED IN AN UNINTENDED MANNER OR SHOWS INDICATIONS THAT IT HAS BEEN ALTERED IN ANY WAY, INCLUDING, BUT NOT LIMITED TO, MODIFICATION OF THE SPEED GOVERNOR, BRAKING SYSTEM, STEERING, TRANSAXLE, OR OTHER OPERATING SYSTEMS OF THE CAR TO CAUSE IT TO PERFORM OUTSIDE CLUB CAR SPECIFICATIONS. THE WARRANTY IS LIKEWISE VOID IF THE CAR SHOWS INDICATIONS THAT REASONABLE OR NECESSARY MAINTENANCE AS OUTLINED IN THE OWNER'S MANUAL AND MAINTENANCE AND SERVICE MANUAL WAS NOT PERFORMED AT THE TIME AND IN THE MANNER SPECIFIED IN SUCH MANUALS.

4. SOLE REMEDY:

CLUB CAR's only liability under this limited warranty, or in any action, whether based upon warranty, contract, negligence, strict product liability, or otherwise, is limited to the repair or replacement, at CLUB CAR's option, of a golf car or component thereof that CLUB CAR deems to be defective. Replacement shall mean furnishing, during the applicable limited warranty period, a new golf car or factory reconditioned vehicle or component thereof which is identical or reasonably equivalent to the warranted product or component at no cost to the purchaser. Repair shall mean remedying a defect in the golf car or component thereof at no cost to the purchaser during the applicable limited warranty period. If CLUB CAR elects to repair the golf car, it may provide factory reconditioned parts or components. All parts and components replaced under warranty shall become the property of CLUB CAR.

5. HOW TO MAKE A WARRANTY CLAIM:

To make a warranty claim under this limited warranty, you must present the golf car or defective component to an authorized CLUB CAR distributor or dealer or send the defective component, freight prepaid, to WARRANTY ADMINISTRATION, CLUB CAR, INC., 4125 Washington Road, Augusta, Georgia 30809.

6. DISCLAIMER:

THIS LIMITED WARRANTY IS EXCLUSIVE. CLUB CAR MAKES NO OTHER WARRANTY OF ANY KIND, EXPRESS OR IMPLIED. ANY IMPLIED WARRANTIES OF MERCHANTABILITY OR FITNESS FOR A PARTICULAR PURPOSE WHICH EXCEED THE OBLIGATIONS OR TIME LIMITS STATED IN THIS WARRANTY ARE HEREBY DISCLAIMED BY CLUB CAR AND EXCLUDED FROM THIS WARRANTY. THE PURCHASER AND CLUB CAR EXPRESSLY AGREE THAT THE REMEDY OF REPLACEMENT OR REPAIR OF THE DEFECTIVE GOLF CAR OR COMPONENT THEREOF IS THE EXCLUSIVE AND SOLE REMEDY OF THE PURCHASER. CLUB CAR MAKES NO OTHER REPRESENTATION OR WARRANTY OF ANY KIND, AND NO REPRESENTATIVE, EMPLOYEE, DISTRIBUTOR OR DEALER OF CLUB CAR HAS THE AUTHORITY TO MAKE OR IMPLY ANY REPRESENTATION, PROMISE OR AGREEMENT WHICH IN ANY WAY VARIES THE TERMS OF THIS WARRANTY.

7. NO CONSEQUENTIAL DAMAGES:

IN NO EVENT SHALL CLUB CAR BE LIABLE FOR ANY INCIDENTAL OR CONSEQUENTIAL DAMAGES INCLUDING, BUT NOT LIMITED TO, LOSS RELATED TO PROPERTY OTHER THAN THE GOLF CAR, LOSS OF USE, LOSS OF TIME, INCONVENIENCE, OR ANY OTHER ECONOMIC LOSS.

Some states allow neither limitation on the duration of an implied warranty nor exclusions or limitation of incidental or consequential damages. Therefore, the above limitations or exclusions may not apply to you.

This warranty gives you specific legal rights, and you may also have other rights which vary from state to state.

8. INFORMATION:

For further information contact WARRANTY ADMINISTRATION, CLUB CAR, INC., P.O. Box 204658, Augusta, Georgia 30917-4658, U.S.A., 706-863-3000.

9. WARNING:

Any modification or alteration of any golf car beyond factory specifications, including those that affect the weight distribution, stability, or speed of the golf car, can cause serious personal injury or death.

FOREWORD

Thank you for choosing Club Car, the golf car most widely recognized as the industry leader in vehicle efficiency and long-lasting value. You have chosen the finest golf car on the market. Please protect your investment and ensure that your Club Car provides years of reliable, superior performance by returning your Warranty Registration (provided by your distributor/dealer), and by reading and following the maintenance instructions in this manual.

Your comfort and safety are important to us as well, so we urge you to read and follow the step-by-step operating instructions and safety procedures in this manual. These instructions must be followed in order to avoid the risk of severe personal injury. If you rent or loan your vehicle to others, we recommend that you ask them to read this manual before they operate the vehicle.

Club Car products are backed by a customer support system designed to offer you fast, courteous service. In the event that your golf car needs repairs or service, we recommend that your local authorized Club Car representative perform them. For the name and address of the Club Car representative nearest you, logon to our web site at www.clubcar.com or call 1-800-ClubCar (258-2227). If you would prefer to write to us, direct your letter to: Club Car, Attention: Marketing Services, P.O. Box 204658, Augusta, Ga. 30917-4658 USA. Your local authorized Club Car representative can also provide technical advice, parts, and service manuals.

We hope you will consider this owner's manual a permanent part of your golf car. If you sell the vehicle, please include the manual so that the next owner will have the important operating, safety, and maintenance information it contains.

TABLE OF CONTENTS

Safety Details	2
General Warnings	3
Vehicle Feature Identification	4
General Information	5
Model Identification	5
Safety Committee	5
Pre-Operation Checklist	6
Controls	7
Driving Instructions	10
Towing	12
Transporting on a Trailer	13
Storage	13
Maintenance	15
Daily Pre-Operation Safety Checklist	15
Periodic Service Schedule	16
Periodic Lubrication Schedule	17
Vehicle Capacities	18
Engine Oil	18
Fueling Instructions	19
Battery	19
Cleaning the Vehicle	21
Accessories	21
Subsequent Owner Registration	22
Fairway Villager	22
DS Gasoline Vehicle Specifications	23

Practice Safety



Safety signs like you see above may at first seem shocking, but their impact is mild compared with the reality of severe personal injury.

Your safety and satisfaction are of the utmost importance to Club Car. That is why before operating the vehicle, we urge you to review the information in this manual. Understand and become familiar with the **DANGER**, **WARNING** and **CAUTION** statements and procedures it contains, along with the safety decals that are affixed to your vehicle.

Take time to understand the language of safety. It is a language that can save your life.

SAFETY DETAILS

⚠ WARNING

- THIS OWNER'S MANUAL SHOULD BE READ COMPLETELY BEFORE ATTEMPTING TO DRIVE OR SERVICE THE VEHICLE. FAILURE TO FOLLOW THE INSTRUCTIONS IN THIS MANUAL COULD RESULT IN PROPERTY DAMAGE, SEVERE PERSONAL INJURY, OR DEATH.

It is important to note that some vital statements throughout this manual and on the decals affixed to the vehicle are preceded by the words DANGER, WARNING, CAUTION, or NOTE. For your protection, we recommend that you take special notice of these safety procedures. Safety procedures are essential and must be followed.

Throughout this manual and on the operation and warning decals affixed to the vehicle, the words "golf car" and "vehicle" are used interchangeably. "Golf car" is defined in the Notice of this manual and no other representation is stated or implied.

If any of the operation or warning decals on the vehicle become damaged, have been removed or cannot be easily read, they should be replaced immediately to avoid possible personal injury, property damage, or death. Contact your Club Car distributor/dealer.

⚠ DANGER

- A DANGER INDICATES AN IMMEDIATE HAZARD WHICH WILL RESULT IN SEVERE PERSONAL INJURY OR DEATH.

⚠ WARNING

- A WARNING INDICATES AN IMMEDIATE HAZARD WHICH COULD RESULT IN SEVERE PERSONAL INJURY OR DEATH.

⚠ CAUTION

- A CAUTION INDICATES HAZARDS OR UNSAFE PRACTICES WHICH COULD RESULT IN MINOR PERSONAL INJURY OR PRODUCT OR PROPERTY DAMAGE.

NOTE

- A NOTE PROVIDES KEY INFORMATION TO MAKE PROCEDURES MORE EASILY UNDERSTOOD.

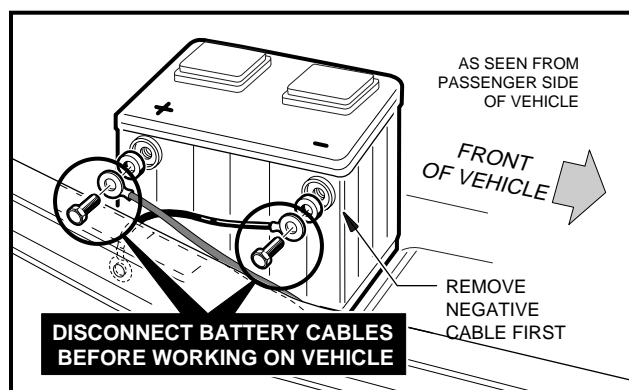

Figure 1 Battery Cable Removal

GENERAL WARNINGS

The safety statements listed must be followed whenever the vehicle is being operated, repaired, or serviced. Vehicle feature identification information is also included on page 4. Other specific WARNING statements appear throughout this manual and on the vehicle.

DANGER

- **BATTERY VAPORS - FLAMMABLE! EXPLOSIVE! DO NOT SMOKE. KEEP SPARKS AND FLAMES AWAY FROM THE AREA OF THE VEHICLE. SERVICE ONLY IN WELL-VENTILATED AREAS.**
- **GASOLINE VAPORS - FLAMMABLE! EXPLOSIVE! DO NOT SMOKE. KEEP SPARKS AND FLAMES AWAY FROM THE AREA OF THE VEHICLE. SERVICE ONLY IN WELL-VENTILATED AREAS.**
- **DO NOT OPERATE GASOLINE VEHICLE IN ENCLOSED AREA WITHOUT PROPER VENTILATION. ENGINE PRODUCES CARBON MONOXIDE WHICH IS AN ODORLESS, DEADLY POISON.**
- **A GOLF CAR WILL *NOT* PROVIDE PROTECTION FROM LIGHTNING, FLYING OBJECTS, OR OTHER STORM RELATED HAZARDS. IF CAUGHT IN A STORM WHILE DRIVING A GOLF CAR, EXIT THE VEHICLE AND SEEK SHELTER IN ACCORDANCE WITH APPLICABLE SAFETY GUIDELINES FOR YOUR LOCATION.**

WARNING

- NEVER LEAVE CHILDREN UNATTENDED IN THE VEHICLE.
- WHEN STOPPING AND LEAVING THE VEHICLE, ALWAYS:
 - TURN THE KEY SWITCH TO **OFF** AND REMOVE THE KEY.
 - PLACE THE FORWARD/REVERSE HANDLE IN **NEUTRAL**.
 - ENGAGE THE PARK BRAKE.
- THE ENGINE EXHAUST FROM THIS PRODUCT CONTAINS CHEMICALS KNOWN TO THE STATE OF CALIFORNIA TO CAUSE CANCER, BIRTH DEFECTS OR OTHER REPRODUCTIVE HARM.
- ONLY TRAINED TECHNICIANS SHOULD REPAIR OR SERVICE THE VEHICLE. ANYONE DOING EVEN SIMPLE REPAIRS OR SERVICE SHOULD FOLLOW THE PROCEDURES EXACTLY AS STATED IN THIS MANUAL, AND FOLLOW ALL **DANGER**, **WARNING**, AND **CAUTION** PROCEDURES LISTED IN THIS MANUAL AS WELL AS THOSE AFFIXED TO THE VEHICLE.
- WEAR SAFETY GLASSES OR APPROVED EYE PROTECTION WHEN SERVICING THE VEHICLE. WEAR A FULL FACE SHIELD WHEN WORKING WITH BATTERIES.
- USE INSULATED TOOLS WHEN WORKING AROUND BATTERIES OR ELECTRICAL CONNECTIONS.
- IMPROPER USE OF THE VEHICLE OR FAILURE TO PROPERLY MAINTAIN IT COULD RESULT IN DECREASED VEHICLE PERFORMANCE OR SEVERE PERSONAL INJURY.
- ANY MODIFICATION OR CHANGE TO THE VEHICLE WHICH AFFECTS THE STABILITY OR HANDLING OF THE VEHICLE, OR INCREASES MAXIMUM VEHICLE SPEED BEYOND FACTORY SPECIFICATIONS, COULD RESULT IN SEVERE PERSONAL INJURY OR DEATH.
- FRAME GROUND - DO NOT ALLOW TOOLS OR OTHER METAL OBJECTS TO CONTACT FRAME WHEN DISCONNECTING BATTERY OR OTHER ELECTRICAL WIRING. NEVER ALLOW A POSITIVE WIRE TO TOUCH THE VEHICLE FRAME, ENGINE OR OTHER METAL COMPONENT.
- PRIOR TO SERVICING THE VEHICLE:
 - TURN THE KEY SWITCH TO **OFF** AND REMOVE THE KEY.
 - PLACE THE FORWARD/REVERSE HANDLE IN **NEUTRAL** AND CHOCK THE WHEELS.
 - DISCONNECT BATTERY, NEGATIVE CABLE FIRST, **(FIGURE 1, PAGE 2)**.
 - DISCONNECT THE SPARK PLUG WIRE FROM THE SPARK PLUG.

DS GASOLINE VEHICLE

DRIVER/PASSENGER WARNING DECAL

WARNING

READ AND FOLLOW THESE WARNINGS AND THE OPERATING INSTRUCTIONS BEFORE USING VEHICLE. FAILURE TO DO SO CAN CAUSE SEVERE INJURY OR DEATH.

- Operation from driver side by authorized persons only and only in designated areas - not on public roads.
- DO NOT start vehicle until all occupants (two (2) per seat maximum) are seated.
- Remain seated with entire body inside vehicle and hold on to seat handle or handrail at all times.
- Drive slowly in turns and straight up and down slopes.
- Never stand in front of or behind vehicle.
- DO NOT operate while under the influence of alcohol or drugs.
- DO NOT leave children unattended on vehicle at any time.

CCI 1019606-01

KEY SWITCH



OPERATING INSTRUCTIONS

- Read Owner's Manual and safety warnings located on dash panel prior to driving.
 - Study and understand controls.
 - Make sure wheels are turned in desired direction.
 - Turn key to "ON" position and be sure nothing is in your path.
 - While vehicle is stopped, select direction by placing shift lever or switch in desired position:
F - Forward N - Neutral R - Reverse (Buzzer will sound)
 - Vehicle will start moving when accelerator pedal is depressed.
 - Slowly depress accelerator pedal to increase speed. Park brake will release when accelerator pedal is depressed.
 - To stop, release accelerator pedal and depress brake pedal.
 - After stopping, firmly depress park brake until it locks.
 - Place forward and reverse switch in neutral position.
Turn key "OFF" and remove key when not in use.
- CCI 1016216-01

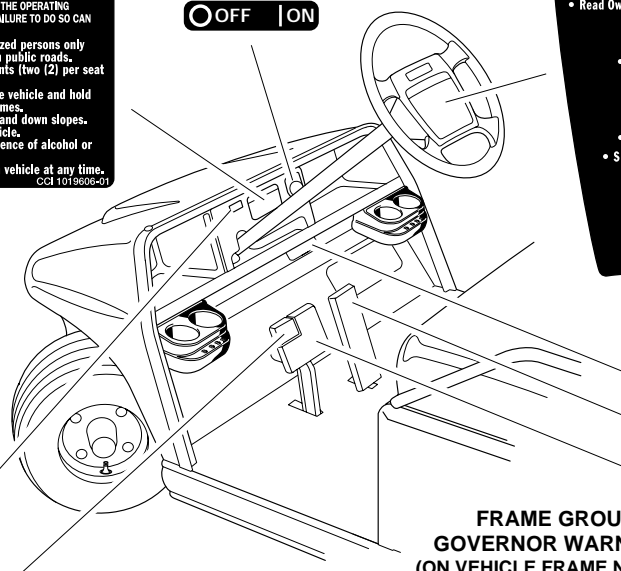

OPERATING INSTRUCTIONS DECAL

SERIAL NUMBER

ACCELERATOR PEDAL

BRAKE PEDAL

OIL WARNING LIGHT

FRAME GROUND AND GOVERNOR WARNING DECAL (ON VEHICLE FRAME NEAR BATTERY)

PARK BRAKE PEDAL

	<p>WARNING</p> <p>Negative frame ground. Can cause severe injury. Do not contact positive (+) battery post or cable to frame. Disconnect negative battery lead first.</p>		<p>WARNING</p> <p>Excessive speed. Can cause severe injury or death. Do not tamper with engine governor adjustment.</p> <p>CCI 1019152-01</p>
--	--	--	--

GASOLINE WARNING DECAL (ON VEHICLE FRAME NEAR FUEL TANK)

WARNING

GASOLINE EXPLOSION / FIRE CAN CAUSE SEVERE INJURY OR DEATH. NO SMOKING, SPARKS, OR OPEN FLAME. STOP ENGINE. ALLOW TO COOL BEFORE REFUELING. TURN FUEL VALVE (OFF) ON DURING OPERATION. (OFF) OFF DURING STORAGE OR TRANSPORT.

CCI 1015476-01

ROTATING PARTS AND HOT MANIFOLD DECAL (ON STARTER/GENERATOR AND ENGINE)

WARNING

CAN CAUSE SEVERE INJURY

Rotating parts

HOT manifold & muffler

KEEP CLEAR CCI 1019605-01

OIL FILL

FUEL SHUT-OFF VALVE

FORWARD/REVERSE HANDLE

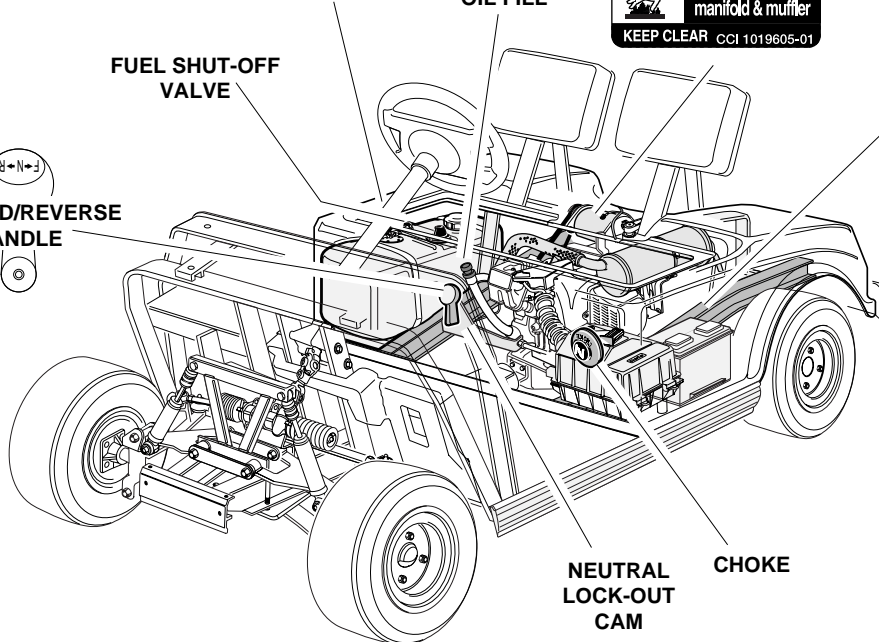

NEUTRAL LOCK-OUT CAM

CHOKE

GENERAL INFORMATION

We urge the owner/operator to read and understand this manual, and to pay special attention to the features specific to his/her vehicle(s).

MODEL IDENTIFICATION

The serial number of your Club Car is printed on a bar code decal mounted on the frame directly above the accelerator pedal (Example: AG0001-123456) (**Figure 2, Page 5**). There is also a second serial number decal mounted on the front body frame behind the center dash panel. The center dash panel must be removed to access it. **See following NOTE.**

NOTE

- ALWAYS HAVE THE VEHICLE SERIAL NUMBER AT HAND WHEN ORDERING PARTS OR MAKING INQUIRIES. IF THE VEHICLE IS EQUIPPED AS A FAIRWAY VILLAGER FOUR PASSENGER VEHICLE, READ THE SPECIAL INSTRUCTIONS BEGINNING ON PAGE 22.

SAFETY COMMITTEE

If the golf car is to be rented or is part of a fleet, we strongly recommend that a safety committee be appointed. One of the main concerns of this committee should be the safe operation of the golf cars.

This should include at a minimum:

- Where golf cars should be driven.
- Ensuring that proper warnings of driving hazards are displayed and visible.
- Who should and who should not drive golf cars.
- Instructing first time drivers.
- Maintaining golf cars in a safe driving condition.
- How various rules are to be enforced.

The safety committee should include all these items and such others as the committee feels necessary or appropriate.

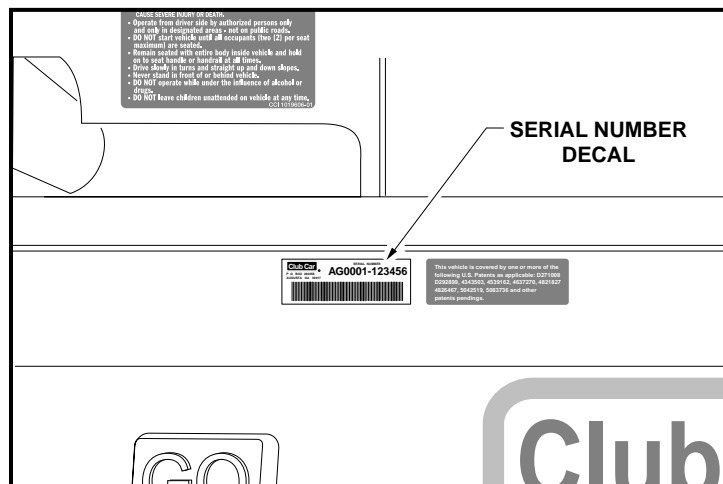

Figure 2 Serial Number Location

PRE-OPERATION CHECKLIST

Your Club Car has been thoroughly inspected and adjusted at the factory, and also by your Club Car distributor/dealer. However, upon arrival of your new Club Car(s), you should become familiar with its controls and operation, and carefully inspect each vehicle to be satisfied that it is in proper working condition before accepting delivery.

Use the following checklist as a guide to inspect your new vehicle. This checklist may also be used in conjunction with the Periodic Service Schedule on page 16. Any problems should be corrected only by your Club Car distributor/dealer or a trained technician.

- **General:** All the parts should be in place and properly installed. Be sure that all nuts, bolts, and screws are tight. Check all hose clamps for tight fit as well as the starter belt for tightness.
- **Warning Decals:** Check to ensure that all warning and operation decals are in place. **See Page 4.**
- **Tires:** Check for proper tire pressure. **See Vehicle Capacities, Page 18.**
- **Engine:** Check for proper engine oil level. **See Engine Oil, Page 18.**
- **Fuel:** Check fuel level. **See Fueling Instructions, Page 19.**

WARNING

- BE SURE THE PLASTIC HAS BEEN REMOVED FROM THE SEAT BOTTOM BEFORE OPERATING THE VEHICLE. FAILURE TO DO SO MAY RESULT IN A FIRE, PROPERTY DAMAGE, PERSONAL INJURY, OR DEATH.

PERFORMANCE INSPECTION

After you have familiarized yourself with the vehicle's controls and have read and understood the driving instructions, take the vehicle for a test drive. Use the following checklist as a guide to inspect your new vehicle. Any problems should be corrected only by your Club Car distributor/dealer or a trained technician.

All vehicles

- **Brakes:** Be sure the brakes function properly. When brake pedal is fully depressed under moderate pressure, it should **not** go more than halfway to the floor, and vehicle should come to a smooth, straight stop within 14 feet. If the pedal goes more than halfway to the floor, or if the vehicle swerves or fails to stop within 14 feet, have the brake system checked and adjusted as required. Brake adjustment must be maintained so that the brake pedal **cannot** be depressed to the floor under any circumstance.
- **Park Brake:** When latched, the park brake should lock the wheels and hold the vehicle stationary (on incline of 20% or less). It should release when either the accelerator or brake pedal is depressed.
- **Reverse Buzzer:** The reverse buzzer should sound as a warning when the vehicle is in reverse.
- **Steering:** The vehicle should be easy to steer and should not have any play in the steering wheel.
- **Accelerator:** With the key switch ON and the forward/reverse handle in the FORWARD position; as the accelerator pedal is depressed, the engine should start and the vehicle should come up smoothly to full speed. When the pedal is released it should return to the original position and the engine should stop. All DS vehicles operate at reduced speed in reverse.
- **Governor:** Check maximum speed of the vehicle. The vehicle should operate at 12-15 MPH (19-24 KPH) on a level surface.
- **General:** Listen for any unusual noises such as squeaks or rattles. Check the vehicle's ride and performance. Have a Club Car distributor/dealer or a trained technician investigate anything unusual.

CONTROLS

Read **DANGER** and **WARNING** on page 3.

⚠ WARNING

- IF RENTING OR LOANING THE VEHICLE, MAKE SURE THE DRIVER IS FAMILIAR WITH ALL CONTROLS AND OPERATING PROCEDURES BEFORE ALLOWING THE VEHICLE TO BE DRIVEN.
- DO NOT TAMPER WITH THE GOVERNOR. DOING SO WILL VOID THE WARRANTY, AS WELL AS DAMAGE THE ENGINE AND OTHER COMPONENTS, AND COULD RESULT IN PROPERTY DAMAGE, PERSONAL INJURY, OR DEATH DUE TO ACCIDENT AT UNSAFE SPEED.
- DO NOT SHIFT THE FORWARD/REVERSE HANDLE WHILE THE VEHICLE IS MOVING. TO AVOID INJURY TO AN UNSUSPECTING PASSENGER OR DAMAGE TO THE VEHICLE, ALWAYS BRING THE VEHICLE TO A FULL STOP BEFORE SHIFTING THE F&R HANDLE.
- RELEASE THE ACCELERATOR PEDAL AND THEN DEPRESS THE BRAKE PEDAL FIRMLY UNTIL THE VEHICLE STOPS. TO AVOID UNINTENTIONALLY STARTING OR ROLLING THE VEHICLE, SET THE PARK BRAKE, TURN THE KEY SWITCH TO **OFF**, AND REMOVE THE KEY WHEN LEAVING THE VEHICLE.

KEY SWITCH

The key switch is mounted on the dash to the right of the steering column (**Figure 3, Page 7**). It has two positions, OFF and ON, which are clearly labeled. **See following NOTE.**

NOTE

- THE KEY CAN BE REMOVED WHEN THE KEY SWITCH IS IN THE **OFF** POSITION ONLY.

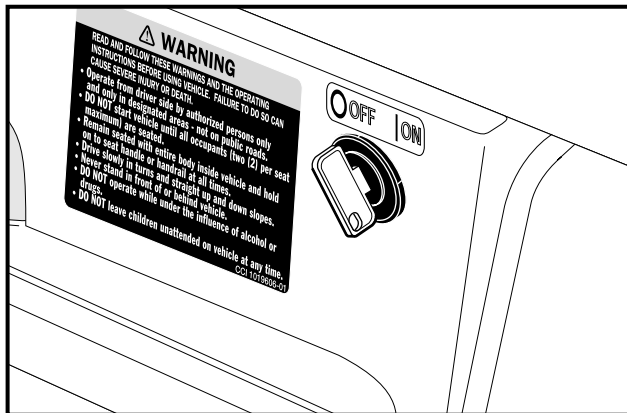

Figure 3 Key Switch

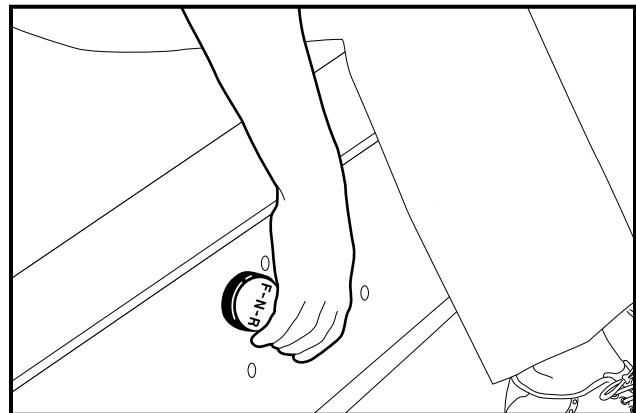

Figure 4 Forward/Reverse Handle

FORWARD/REVERSE CONTROL

The Forward/Reverse handle is located on the seat support panel, below and to the right of the driver's right knee (**Figure 4, Page 7**). The handle has three distinct positions: **F** (FORWARD), **N** (NEUTRAL), and **R** (REVERSE). Rotate the handle towards the driver, **F** (FORWARD), to operate the vehicle in the forward direction, or towards the passenger, **R** (REVERSE), to operate the vehicle in reverse. When the handle is in the straight up, or **N** (NEUTRAL) position, the vehicle will not operate. The engine will stop if it is shifted to this position during operation. DS vehicles operate at reduced speed in reverse. When the vehicle is in reverse, the reverse warning buzzer will sound.

ACCELERATOR PEDAL

The accelerator pedal is the pedal on the right, with the word **GO** molded into it (**Figure 5, Page 8**). The operation of the accelerator pedal differs from that of an automobile. When the key switch is ON, and the Forward/Reverse handle is in either FORWARD or REVERSE, depressing the accelerator pedal will automatically release the park brake and start the vehicle moving in the direction selected (FORWARD or REVERSE). As the accelerator pedal is depressed, speed will increase until full speed is reached. When the accelerator is released, power will be cut off and the engine will stop running.

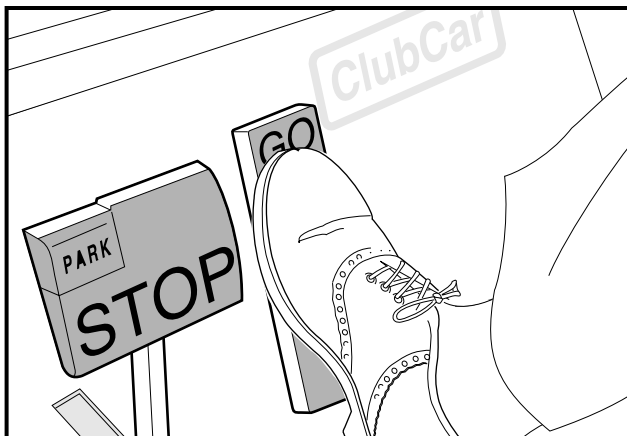

Figure 5 Accelerator and Brake Pedal

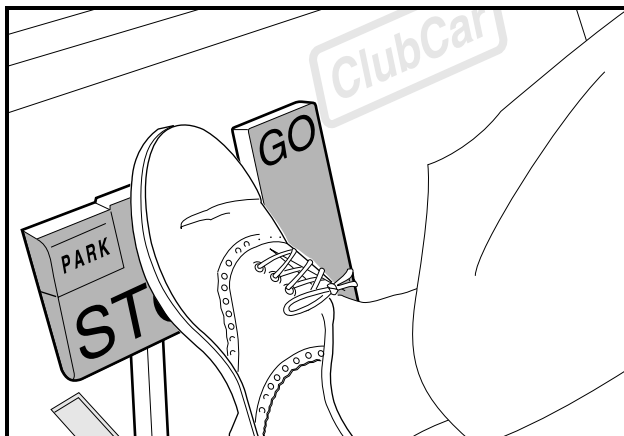

Figure 6 Brake Pedal

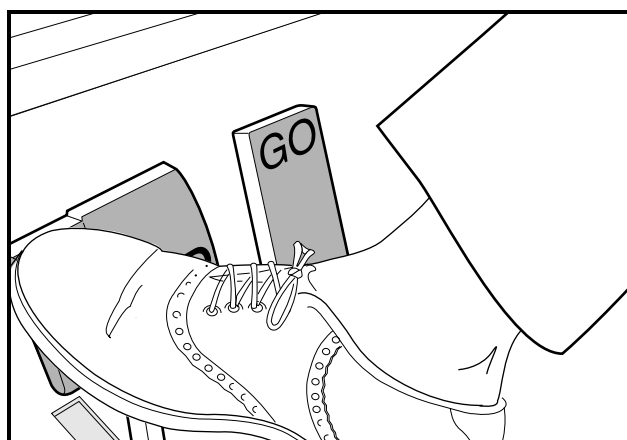

Figure 7 Park Brake Pedal

BRAKE PEDAL

The brake pedal is the large pedal on the left with the word **STOP** molded into it (**Figure 5, Page 8**). To slow or stop the vehicle, depress the brake pedal with your foot (**Figure 6, Page 8**).

PARK BRAKE PEDAL

The park brake pedal is the small raised portion in the upper left corner of the brake pedal. It has the word **PARK** molded into it and the words **PARK BRAKE** marked on top of it (**Figure 7, Page 8**). To set the park brake, depress the brake pedal firmly and tilt the park brake portion of the pedal forward with your foot (**Figure 7, Page 8**). See following **WARNING**.

⚠ WARNING

- THE PARK BRAKE WILL RELEASE AUTOMATICALLY WHEN EITHER THE ACCELERATOR OR BRAKE PEDAL IS DEPRESSED. THE PARK BRAKE HAS MULTIPLE LOCKING POSITIONS AND SHOULD BE FIRMLY PRESSED AND LOCKED TO PREVENT THE VEHICLE FROM ROLLING.

NEUTRAL LOCK-OUT

For the convenience of the trained technician, there is a neutral lock-out cam located on the back of the Forward/Reverse handle. If the neutral lock-out cam is pulled out approximately 3/8 inch (10 mm) and then rotated one-half turn until it snaps into place, the cam will be in the SERVICE position (**Figure 8, Page 9**). This will allow the technician to operate the engine in NEUTRAL for certain maintenance procedures. With the cam in this position, the vehicle will not operate if the Forward/Reverse handle is placed in either the FORWARD or REVERSE position.

To put the cam back into the OPERATE position, pull the cam out approximately 3/8 inch (10 mm) and rotate it one-half turn until it snaps into place (**Figure 9, Page 9**). See following **WARNING** and **NOTE**.

⚠ WARNING

- WITH THE CAM IN THE **SERVICE** POSITION AND THE ENGINE RUNNING, THE VEHICLE MAY MOVE SUDDENLY IF THE FORWARD/REVERSE HANDLE IS SHIFTED OR ACCIDENTALLY BUMPED. TO PREVENT THIS, CHOCK THE FRONT AND REAR WHEELS AND ALWAYS FIRMLY SET THE PARK BRAKE BEFORE SERVICING OR LEAVING THE VEHICLE.

NOTE

- BE SURE TO RETURN THE CAM TO THE **OPERATE** POSITION AFTER SERVICING THE VEHICLE, OR IT WILL NOT OPERATE WITH THE FORWARD/REVERSE HANDLE IN EITHER THE **FORWARD** OR **REVERSE** POSITION.

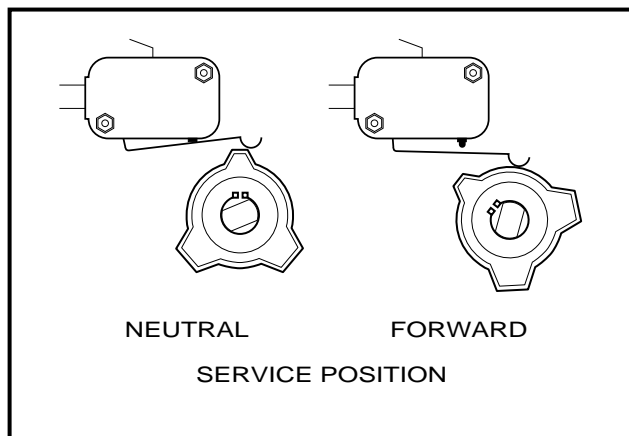

Figure 8 Neutral Lock-out – Service

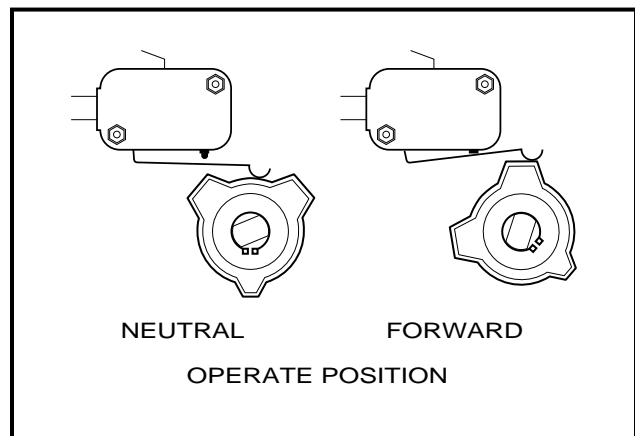

Figure 9 Neutral Lock-out – Operate

CHOKER

The choke is located on the seat support panel below and to the left of the driver's left knee (**Figure 10, Page 10**). If the vehicle is hard to start in cool or cold temperatures, simply push in the choke cover with your left hand to activate it. Hold it during start up and release the choke cover after the engine starts and operates smoothly.

OIL LIGHT

The DS Gasoline golf car is equipped with a low oil warning light, located on the dash panel just above the steering column (**Figure 11, Page 10**). If the oil warning light comes on, oil should be checked and added to the engine as necessary before continuing to use the vehicle. The vehicle should never be driven with the oil warning light remaining on. If the oil warning light goes on and off, you may proceed, but oil should be added at the first opportunity. If the oil level is correct and the light stays on, have a trained technician check the vehicle. See following **CAUTION**.

⚠ CAUTION

- FAILURE TO ADD OIL IMMEDIATELY WHEN THE OIL WARNING LIGHT STAYS ON MAY RESULT IN PERMANENT ENGINE DAMAGE.

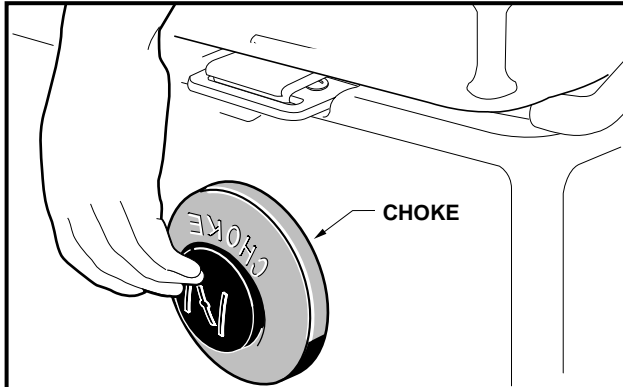

Figure 10 Choke

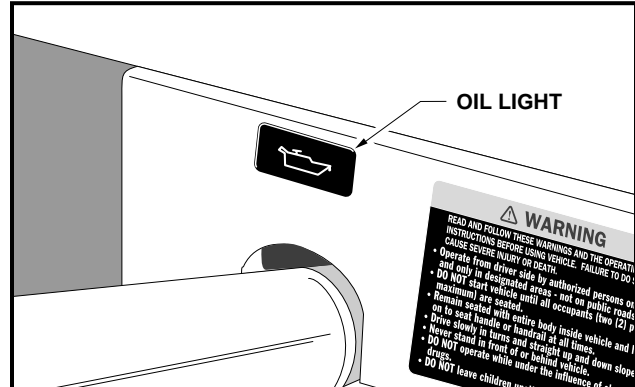

Figure 11 Oil Light

DRIVING INSTRUCTIONS**⚠ WARNING**

- ONLY LICENSED DRIVERS SHOULD BE ALLOWED TO DRIVE THIS VEHICLE.
- IF RENTING OR LOANING THE VEHICLE, MAKE SURE THE DRIVER IS FAMILIAR WITH ALL CONTROLS AND OPERATING PROCEDURES BEFORE ALLOWING THE VEHICLE TO BE DRIVEN.
- NO MORE THAN TWO PEOPLE SHOULD BE ON THE VEHICLE AT ONE TIME.
- THE VEHICLE IS NOT SPECIALLY EQUIPPED FOR HANDICAPPED PERSONS:
 - BE SURE ALL PERSONS CAN PROPERLY OPERATE THE VEHICLE PRIOR TO ALLOWING THEM TO DRIVE THE VEHICLE.
 - BE SURE ALL PASSENGERS ARE CAPABLE OF SECURING THEMSELVES IN A MOVING VEHICLE BEFORE ALLOWING THEM TO RIDE IN ONE.
- FOR NIGHT USE, THE VEHICLE MUST BE EQUIPPED WITH HEADLIGHTS, TAILLIGHTS, AND REFLECTORS.
- STOP THE VEHICLE BEFORE SHIFTING THE FORWARD/REVERSE HANDLE. FAILURE TO DO SO MAY RESULT IN INJURY TO AN UNSUSPECTING PASSENGER AND (OR) DAMAGE TO THE VEHICLE.
- DO NOT LEAVE CHILDREN UNATTENDED IN THE VEHICLE.
- TO AVOID BEING STRUCK, DO NOT STAND IN FRONT OF OR BEHIND THE VEHICLE.

WHEN DRIVING THE VEHICLE:

- OPERATE THE VEHICLE FROM THE DRIVER SEAT ONLY.
- TO PREVENT FALLS FROM THE VEHICLE, REMAIN SEATED IN A MOVING VEHICLE AND HOLD ON TO SEAT HANDLES OR HANDRAILS AT ALL TIMES. DRIVER SHOULD KEEP BOTH HANDS ON THE STEERING WHEEL WHEN THE VEHICLE IS IN MOTION.
- TO PREVENT THE POSSIBILITY OF SERIOUS INJURY, KEEP YOUR ENTIRE BODY INSIDE THE VEHICLE.
- TO PREVENT OVERTURNING THE VEHICLE, DRIVE SLOWLY IN TURNS.
- TO PREVENT OVERTURNING THE VEHICLE, DRIVE SLOWLY STRAIGHT UP AND DOWN SLOPES. **DO NOT DRIVE THE VEHICLE ON SLOPES EXCEEDING 20% INCLINE.**
- TO AVOID POSSIBLE INJURY TO AN INATTENTIVE PASSENGER AND (OR) DAMAGE TO THE VEHICLE, AVOID SUDDEN STARTS, SUDDEN STOPS, AND ABRUPT TURNS.
- TO AVOID THE POSSIBILITY OF LOSING CONTROL OF OR OVERTURNING THE VEHICLE, REDUCE SPEED FOR ADVERSE DRIVING CONDITIONS SUCH AS WET GRASS OR ROUGH TERRAIN.

WARNINGS CONTINUED ON FOLLOWING PAGE...

⚠ WARNING

- DO NOT USE THE VEHICLE ON PUBLIC ROADS. IT IS NOT DESIGNED OR INTENDED FOR STREET USE AND SHOULD NOT BE LICENSED FOR USE ON PUBLIC ROADS.
- OBEY ALL LOCAL RULES CONCERNING GOLF CARS.
- THE VEHICLE SHOULD BE DRIVEN IN ONLY SPECIFIED AREAS BY TRAINED DRIVERS.
- DO NOT DRIVE WHILE UNDER THE INFLUENCE OF ALCOHOL, DRUGS, OR MEDICATIONS.

No one should drive the vehicle without first being instructed in the proper operation and use of the vehicle's controls. An experienced operator should accompany each first-time driver on a test drive before allowing him/her to operate the vehicle alone. Only licensed drivers should be allowed to drive this vehicle.

To ensure safe operation of the vehicle, follow exactly and in order, all of the following procedures. Read and understand all instructions prior to driving the vehicle.

NOTE

- IF THE FORWARD/REVERSE HANDLE IS SHIFTED INTO **NEUTRAL**, POWER WILL BE CUT OFF AND THE ENGINE WILL STOP RUNNING.

STARTING THE VEHICLE

1. Study and understand controls.
2. Make sure everyone is seated and holding onto seat handles or handrails.
3. Read safety warnings located on dash and (or) above pedals.
4. Make sure wheels are turned in desired direction.
5. Turn key to the ON position and make sure nothing is in your path.
6. Select direction by placing Forward/Reverse handle in desired position (F = forward or R = reverse). A buzzer will sound as a warning when the vehicle is in REVERSE.
7. Slowly depress accelerator pedal. The park brake will release automatically and the vehicle will start to move. As the accelerator pedal is depressed, speed will increase until full speed is reached. **See following WARNING.**

⚠ WARNING

- VEHICLE OPERATOR MUST CONTROL SPEED WHEN GOING DOWNHILL.
- NEVER SHIFT THE VEHICLE OUT OF **FORWARD** WHILE GOING DOWNHILL. IF YOU DO, YOU WILL NOT BE ABLE TO SHIFT INTO **REVERSE** OR BACK INTO **FORWARD** UNTIL STOPPED.
- DEPRESS THE BRAKE PEDAL AS NECESSARY AND PARTIALLY DEPRESS THE ACCELERATOR WHEN DESCENDING A HILL. WITH THE ACCELERATOR PEDAL PARTIALLY DEPRESSED, THE GOVERNOR WILL CAUSE THE ENGINE TO ASSIST THE BRAKES IN CONTROLLING DOWNHILL SPEED.

STOPPING THE VEHICLE

To stop the vehicle, release the accelerator pedal and depress the brake pedal with your right foot until the vehicle comes to a complete stop.

⚠ WARNING

- DRIVING THROUGH WATER MAY AFFECT THE BRAKES. AFTER DRIVING THROUGH WATER, CHECK EFFECTIVENESS OF THE BRAKES BY GENTLY DEPRESSING THE BRAKE PEDAL. IF THE VEHICLE DOES NOT SLOW DOWN AT THE NORMAL RATE, CONTINUE TO DEPRESS THE BRAKE PEDAL UNTIL THE BRAKES DRY OUT AND NORMAL PERFORMANCE RETURNS.

⚠ CAUTION

- WHEN STOPPED ON A HILL, USE THE BRAKE PEDAL TO HOLD YOUR POSITION. DO NOT USE THE ACCELERATOR PEDAL.

PARKING AND LEAVING THE VEHICLE

1. After stopping the vehicle, firmly depress the park brake pedal until it locks. This will prevent the vehicle from rolling.
2. Turn key switch to OFF and place the Forward/Reverse handle in the NEUTRAL position. Remove the key and turn fuel shut-off valve to closed (OFF) position when the vehicle is not in use (**Figure 12, Page 12**).

TOWING

All vehicles are equipped with both front and rear tow bar attaching points. A light duty tow bar is available for break-down towing and single vehicle towing. A heavy duty tow bar and an on-board tow bar are available for multi-vehicle towing. **See following WARNING.**

⚠ WARNING

- NEVER TOW THE VEHICLE ON PUBLIC STREETS OR HIGHWAYS.
- USE ONLY APPROVED CLUB CAR TOW BARS.
- TURN THE KEY SWITCH TO **OFF** AND PLACE THE FORWARD/REVERSE HANDLE IN **NEUTRAL** BEFORE TOWING THE VEHICLE.
- EXTREME CAUTION SHOULD BE USED WHEN TOWING ANY VEHICLE.
- DO NOT TOW MORE THAN ONE CLUB CAR VEHICLE WITH ANOTHER CLUB CAR VEHICLE. IF MORE THAN ONE VEHICLE MUST BE TOWED, AN ADEQUATELY POWERED VEHICLE (TRACTOR OR FULL SIZED TRUCK) PROPERLY FITTED, WITH A TOW HITCH HEIGHT OF 11 INCHES SHOULD BE USED. ONLY HEAVY-DUTY TOW BARS SHOULD BE USED FOR MULTI-VEHICLE TOWING. **NEVER TOW MORE THAN FIVE VEHICLES AT ONE TIME.**
- TURN FUEL SHUT-OFF VALVE TO CLOSED (**OFF**) POSITION (**FIGURE 12, PAGE 12**).
- DO NOT EXCEED 5 MPH (8 KPH) TOWING SPEED.
- DO NOT ALLOW PEOPLE IN THE VEHICLES BEING TOWED.
- AVOID SUDDEN STARTS, SUDDEN STOPS, AND TIGHT TURNS WHEN TOWING.

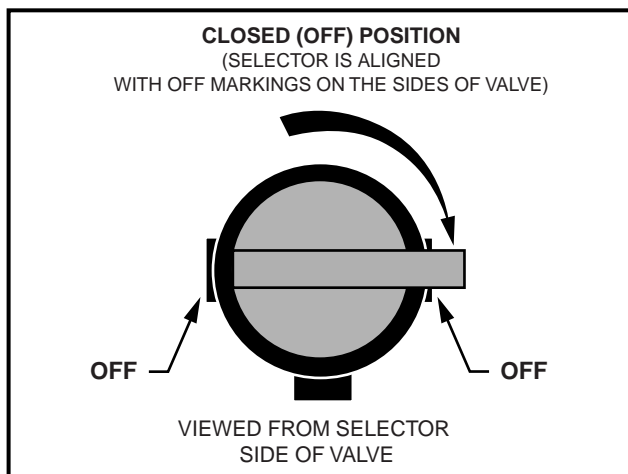

Figure 12 Closed Fuel Shut-off Valve

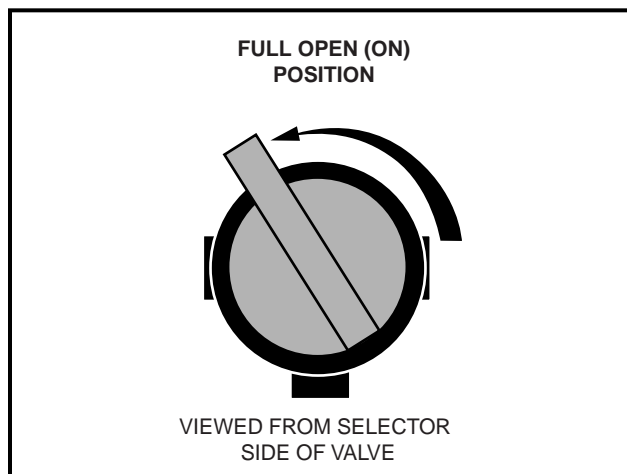

Figure 13 Open Fuel Shut-off Valve

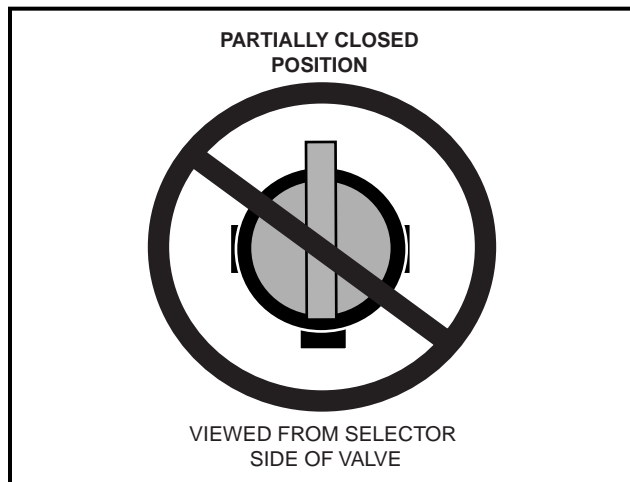

Figure 14 Partially Closed Fuel Shut-off Valve

TRANSPORTING ON A TRAILER

If your vehicle must be transported over long distance or on public highways, it should be done on an approved trailer, and the following WARNING statement should be heeded:

⚠ WARNING

- FOR USE ON PUBLIC ROADS, THE TRAILER MUST MEET ALL FEDERAL, STATE, AND LOCAL REQUIREMENTS SUCH AS TAILLIGHTS, BRAKE LIGHTS, ETC.
- NEVER TOW A CLUB CAR VEHICLE BEHIND A PASSENGER VEHICLE OR TRUCK ON A PUBLIC ROAD UNLESS IT IS ON AN APPROVED TRAILER
- ALWAYS USE AN APPROVED TRAILER THAT HAS A LOAD RATING OF 1200 LB (544 KG) PER VEHICLE TO BE TOWED (EXAMPLE: A TWO-CAR TRAILER SHOULD BE RATED AT 2 X 1200 = 2400 LBS (2 X 544 = 1088 KG)).
- THE VEHICLE TO BE TOWED SHOULD BE TIED SECURELY TO THE TRAILER, WITH THE FORWARD/REVERSE HANDLE IN **NEUTRAL**, THE KEY SWITCH **OFF**, AND THE PARK BRAKE FIRMLY DEPRESSED AND LOCKED.
- WHEN TOWING ON A TRAILER, NORMAL ROAD SPEED OF THE TOW VEHICLE MUST BE REDUCED.
- BECAUSE OF THE ADDED LENGTH OF THE TRAILER, CAUTION SHOULD BE USED WHEN TURNING A CORNER.
- REMOVE THE VEHICLE WINDSHIELD BEFORE TRANSPORTING ON A TRAILER.
- TURN FUEL SHUT-OFF VALVE TO CLOSED (**OFF**) POSITION (**FIGURE 12, PAGE 12**).

STORAGE

Read **DANGER** and **WARNING** on page 3.

⚠ DANGER

- NEVER ATTEMPT TO DRAIN GASOLINE WHEN THE ENGINE IS HOT OR WHILE IT IS RUNNING. BE SURE TO CLEAN UP ANY SPILLED GASOLINE BEFORE OPERATING THE VEHICLE.
- STORE GASOLINE IN AN APPROVED GASOLINE CONTAINER ONLY. STORE IN A WELL-VENTILATED AREA AWAY FROM SPARKS, OPEN FLAMES, HEATERS, OR HEAT SOURCES.
- KEEP GASOLINE OUT OF THE REACH OF CHILDREN.
- DO NOT SIPHON GASOLINE FROM THE VEHICLE.

⚠ WARNING

- DO NOT ATTEMPT TO CHARGE A BATTERY IF IT IS FROZEN OR IF THE CASE IS BULGED. DISCARD THE BATTERY. FROZEN BATTERIES CAN EXPLODE.

⚠ CAUTION

- BATTERIES IN A LOW STATE OF CHARGE WILL FREEZE AT LOW TEMPERATURES.

To prepare your vehicle for extended off season storage:

1. Store vehicle in a cool place. This will help prevent battery self-discharge. If the battery appears to be weak, have it charged using an automotive-type 12-volt battery charger rated 10 amps or less.
2. Drain carburetor.
 - 2.1. Place the Forward/Reverse handle in the NEUTRAL position and the neutral lock-out cam in the SERVICE position. Turn the fuel shut-off valve to the OFF position and operate the engine until fuel remaining in the carburetor and fuel lines is used up and the engine stalls. Return the neutral lock-out cam to OPERATE position.
 - 2.2. Loosen (do not remove) the carburetor drain screw and drain fuel remaining in bowl into a small container, then pour the fuel from the container into vehicle fuel tank. Tighten the carburetor drain screw.
 - 2.3. Disconnect fuel vent line from fuel tank vent nipple.
 - 2.4. Plug the fuel tank vent nipple so that it is air tight. We recommend using a slip-on vinyl cap.
3. To protect the engine, remove the spark plug and pour 1/2 ounce of SAE 10 weight oil into engine through the spark plug hole. Rotate engine crankshaft several times and then re-install spark plug. **See following WARNING.**

⚠ WARNING

- TURN THE KEY SWITCH **OFF**, REMOVE THE KEY, AND LEAVE THE FORWARD/REVERSE HANDLE IN THE **NEUTRAL** POSITION DURING STORAGE. THIS IS TO PREVENT UNINTENTIONALLY STARTING THE VEHICLE OR FIRE HAZARD.

4. Increase tire pressure to 20 psi (138 kPa).
5. Grease front suspension and do all other semi-annual periodic lubrication. **See Periodic Lubrication Schedule, Page 17.**
6. Thoroughly clean front body, rear body, seats, engine compartment, and underside of vehicle.
7. Do not latch the park brake. Chock wheels to prevent the vehicle from rolling.

TO RETURN THE STORED VEHICLE TO SERVICE

1. Restore fuel system to operation.
 - 1.1. Remove plug from the fuel tank vent nipple and connect the vent line to the nipple. Open fuel shut-off valve. Make sure the valve is fully open (**Figure 13, Page 12**). A partially closed fuel valve (**Figure 14, Page 13**) combined with the use of the choke, can result in a fouled spark plug and engine failure.
 - 1.2. Place the Forward/Reverse handle in the NEUTRAL position and the neutral lock-out cam in the SERVICE position. Crank the engine until fuel is pumped into the carburetor and fuel lines and the engine starts. Turn engine off and return neutral lock-out cam to the OPERATE position.
2. Readjust tire pressure to 12-14 psi (83/97 kPa).
3. Perform the Pre-Operation Checklist. **See page 6.**

NOTE

- DUE TO THE OIL ADDED TO THE ENGINE IN PREPARATION FOR STORAGE, THE ENGINE MAY SMOKE EXCESSIVELY FOR A SHORT WHILE WHEN RUNNING IT FOR THE FIRST TIME AFTER STORAGE.

MAINTENANCE

Read **DANGER** and **WARNING** on page 3.

GENERAL INFORMATION

To ensure trouble-free vehicle performance, it is very important to follow an established preventive maintenance program (regularly scheduled service, even though the vehicle is functional). Regular and consistent vehicle maintenance can prevent vehicle down-time and expensive repairs that result from neglect. Any vehicle not functioning correctly should be removed from use until it is properly repaired. This will prevent further damage to the vehicle and avoid the possibility of injury due to unsafe conditions.

Contact your local Club Car distributor/dealer to perform all repairs and semi-annual and annual periodic service. **See following WARNING.**

WARNING

- IF PROBLEMS ARE FOUND DURING SCHEDULED INSPECTION OR SERVICE, DO NOT OPERATE THE VEHICLE UNTIL REPAIRS ARE MADE. FAILURE TO MAKE NECESSARY REPAIRS COULD RESULT IN FIRE, PROPERTY DAMAGE, SEVERE PERSONAL INJURY, OR DEATH.
- MOVING PARTS - DO NOT ATTEMPT TO SERVICE GASOLINE VEHICLE WHILE THE ENGINE IS RUNNING.
- HOT! DO NOT ATTEMPT TO SERVICE HOT ENGINE, MOTOR, RESISTORS, OR EXHAUST SYSTEM. ATTEMPTING TO DO SO COULD CAUSE SEVERE BURNS.
- TURN FUEL SHUT-OFF VALVE TO CLOSED (**OFF**) POSITION (**FIGURE 12, PAGE 12**).
- TO AVOID UNINTENTIONALLY STARTING THE VEHICLE, BEFORE SERVICING ALWAYS DISCONNECT THE BATTERY, NEGATIVE LEAD FIRST (**FIGURE 1, PAGE 2**) AND DISCONNECT THE SPARK PLUG WIRE FROM THE SPARK PLUG.
- FRAME GROUND - DO NOT ALLOW TOOLS OR OTHER METAL OBJECTS TO CONTACT FRAME WHEN DISCONNECTING BATTERIES OR OTHER ELECTRICAL WIRING. NEVER ALLOW A POSITIVE WIRE TO TOUCH THE VEHICLE FRAME, ENGINE, OR OTHER METAL COMPONENT.

DAILY PRE-OPERATION SAFETY CHECKLIST

Inspect and drive the vehicle, using the Pre-operation Checklist (**page 6**) and Performance Inspection (**page 6**) as guides to check the following items.

- Vehicle warning decals
- Brake system
- Park brake
- Reverse warning buzzer
- Steering and linkages
- Proper acceleration and maximum speed

In addition, check the items listed below:

- Tires: Visually inspect for wear, damage and proper inflation.
- Exhaust system: Check for leaks.
- Forward/Reverse shifter: Check for proper operation. **See Controls, Page 7.**
- Fuel system: Check fuel tank, lines, cap, pump, fuel filters and carburetor for fuel leakage.

PERIODIC SERVICE SCHEDULE

Read **DANGER** and **WARNING** on page 3.

WARNING

- SERVICE, REPAIRS, AND ADJUSTMENTS MUST BE MADE PER INSTRUCTIONS IN THE 2000 DS GOLF CAR MAINTENANCE & SERVICE MANUAL.

NOTE

- IF THE VEHICLE IS CONSTANTLY SUBJECTED TO HEAVY USE OR SEVERE OPERATING CONDITIONS, THE PREVENTIVE MAINTENANCE PROCEDURES SHOULD BE PERFORMED MORE OFTEN THAN RECOMMENDED IN THE SERVICE AND LUBRICATION SCHEDULES.
- BOTH THE PERIODIC SERVICE SCHEDULE AND PERIODIC LUBRICATION SCHEDULE MUST BE FOLLOWED TO KEEP VEHICLE IN OPTIMUM OPERATING CONDITION.

PERIODIC SERVICE SCHEDULE

Monthly Service by Owner or Trained technician	Engine	Check engine oil level; change as required. See lubrication schedule, page 17. Dispose of used oil properly. Check engine cooling air intake; clean as necessary. Visually inspect the unshrouded area around engine exhaust for grass and debris and clean as necessary.
	Tires	Check air pressure and adjust as necessary. See Capacities Chart on page 18.
	General Vehicle	Wash engine compartment and underside of vehicle. Do not wash engine when hot. Dispose of waste water properly.
Semi-annual Service by Trained technician Only (Every 50 hours of operation or every 100 rounds for golf cars)	Battery	Clean terminals and wash dirt from casing; Check electrolyte level. See page 19.
	Front Wheel Alignment and Camber	Check and adjust as required. See Maintenance & Service Manual, Section 7.
	Electrical wiring and connections	Check for tightness and damage.
	Brake System	Check brake shoes; replace if necessary.
		Lubricate brake slides per Lubrication Schedule. Check brake cables for damage; replace as required.
Annual Service by Trained technician Only (Every 100 hours of operation or every 200 rounds for golf cars)	Engine	Check for leaks around gaskets, fill plugs, etc.
		Inspect, clean and regap spark plug; replace if necessary.
	Engine Air Intake System	Check air filter element; clean or replace if necessary. Dispose of used filter element properly.
		Check clamps for tightness; check hose for cracks.
General Vehicle	Check for loose hardware and tighten as required.	
Two year Service by Trained technician Only (Every 200 hours of operation or every 400 rounds for golf cars)	Fuel Filters	Replace. Dispose of used filters properly.

⚠ WARNING

- IF PROBLEMS ARE FOUND DURING SCHEDULED INSPECTION OR SERVICE, DO NOT OPERATE THE VEHICLE UNTIL REPAIRS ARE MADE. FAILURE TO MAKE NECESSARY REPAIRS COULD RESULT IN FIRE, PROPERTY DAMAGE, SEVERE PERSONAL INJURY, OR DEATH.

PERIODIC LUBRICATION SCHEDULE

PERIODIC LUBRICATION SCHEDULE			
REGULAR INTERVAL	SERVICE	PLACE*	RECOMMENDED LUBRICANT
Semi-annually by Owner or Trained Technician (Every 50 hours of operation or every 100 rounds for golf cars)	Brake Pedal shaft bearings	1.	Dry Moly Lube - Club Car Part No. 1012151
	Brake Linkage and Pivots	2.	Dry Moly Lube - Club Car Part No. 1012151
	Accelerator push rod pivots, mounts, and shifter cable pivots	3.	Dry Moly Lube - Club Car Part No. 1012151
	Front Suspension (5 fittings)	4.	Chassis Lube - EP NLGI Grade 2
	Brake slides	5.	Dry Moly Lube - Club Car Part No. 1012151
Annually by Trained Technician Only (Every 100 hours of operation or every 200 rounds for golf cars)	Check/fill unitized transaxle to plug level	6.	27 oz. (.8 liter) 80-90 WT. API Class GL-3 or 80-90 WT. AGMA Class EP Gear Lube
	Inspect front wheel bearings (Repack as necessary)	7.	Chassis Lube - EP NLGI Grade 2
First Change 100 Hours - Additional Change Every 200 Hours of Operation (or every 400 rounds for golf cars), or Annually - Whichever Comes First	Change engine oil and oil filter	8.	32 oz. (.97 liter) without filter; 38 oz. (1.16 liters) with filter. See Oil Viscosity on page 18.

*See (Figure 15, Page 17).

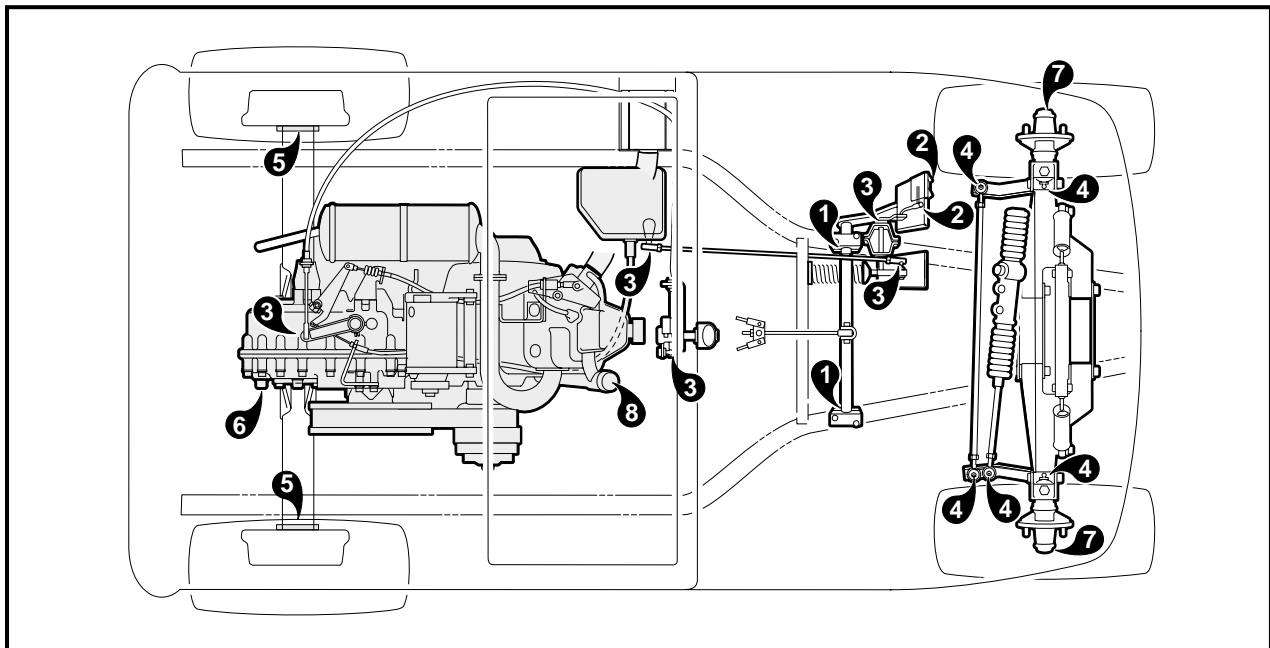

Figure 15 Vehicle Lubrication Points

VEHICLE CAPACITIES

CAPACITIES	
Engine Crankcase without filter	32 oz. (.98 liters)
Engine Crankcase with filter	38 oz. (1.16 liters)
Unitized Transaxle (gas vehicle)	27 oz. (.8 liters)
Gasoline Tank	7 gallons (26.5 liters)
Tire Pressure	12-14 psi (83-96 kPa)

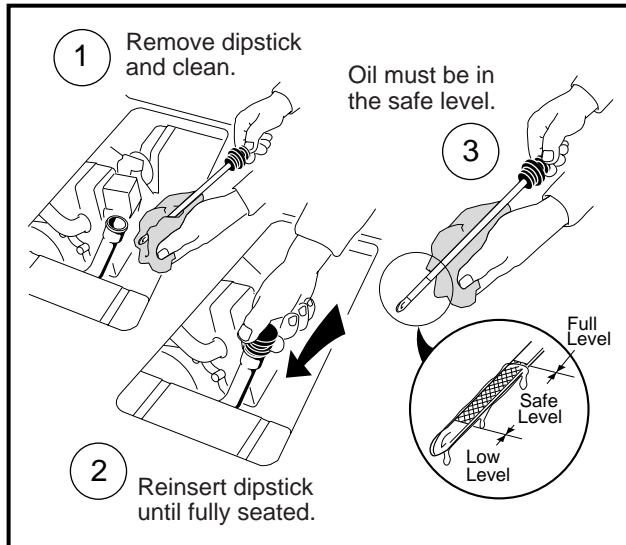

Figure 16 Engine Oil Level

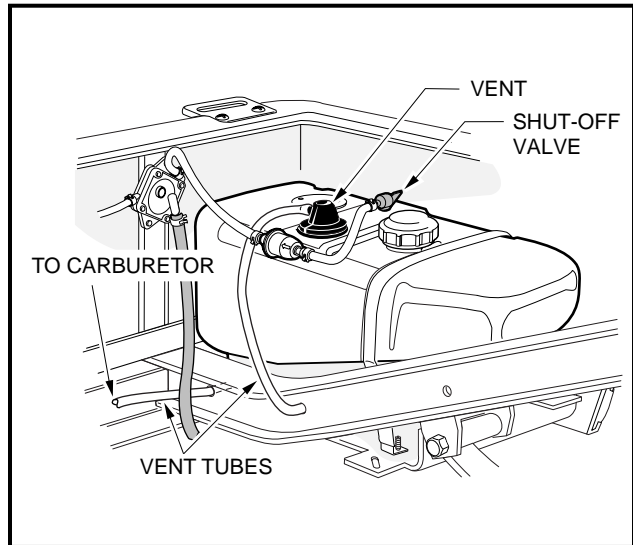

Figure 17 Gasoline Tank

ENGINE OIL

Even though the oil warning light on the dash should warn you if your oil is getting low, engine oil level should be checked monthly. Vehicle should be on a level surface when checking oil (**Figure 16, Page 18**). Do not overfill with oil.

NOTE

- PROPERLY RECYCLE OR DISPOSE OF USED OIL IN ACCORDANCE WITH LOCAL, STATE, AND FEDERAL REGULATIONS.

OIL VISCOSITY

Choose the viscosity according to the temperature as shown (**Figure 18, Page 18**). See following NOTE.

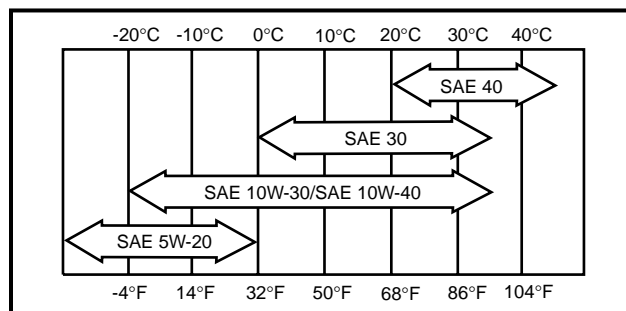

Figure 18 Oil Viscosity

NOTE

- USING MULTI-GRADE OILS (5W-20, 10W-30, AND 10W-40) WILL INCREASE OIL CONSUMPTION. CHECK OIL LEVEL MORE FREQUENTLY WHEN USING THEM.

FUELING INSTRUCTIONS

Read **DANGER** and **WARNING** on page 3.

⚠ DANGER

- **TURN KEY SWITCH TO THE OFF POSITION BEFORE FUELING.**
- **NEVER POUR GASOLINE INTO THE FUEL TANK WHEN THE ENGINE IS HOT OR WHILE IT IS RUNNING.**
- **TO AVOID ELECTRIC ARC CAUSED BY STATIC ELECTRICITY, THE FUEL STORAGE/ PUMPING DEVICE MUST BE GROUNDED. IF THE PUMP IS NOT GROUNDED, THE VEHICLE MUST BE GROUNDED TO THE PUMP BEFORE AND DURING THE FUELING OPERATION.**
- **IF THE VEHICLE HAS AN ALL-WEATHER ENCLOSURE INSTALLED, THE GAS TANK MUST BE PROPERLY VENTED AS SHOWN (SEE FIGURE 17, PAGE 18).**
- **TO AVOID THE POSSIBILITY OF FIRE, BE SURE TO CLEAN UP ANY SPILLED GASOLINE BEFORE OPERATING THE VEHICLE.**

⚠ CAUTION

- **TO ALLOW FOR EXPANSION, DO NOT FILL HIGHER THAN ONE INCH FROM THE TOP OF THE FUEL TANK. AVOID FUEL SPILLAGE.**

NOTE

- **WHENEVER POSSIBLE, AVOID USING OXYGENATED FUELS AND FUELS THAT ARE BLENDED WITH ALCOHOL. VEHICLES TO BE STORED FOR EXTENDED PERIODS SHOULD BE PREPARED FOR STORAGE AS INSTRUCTED ON PAGE 13 OF THIS MANUAL.**

1. Turn the key switch to the OFF position.
2. Lift and remove seat bottom.
3. The fuel tank is located on passenger side of vehicle. Remove fuel cap and fill the fuel tank with fresh unleaded gasoline only. **See preceding CAUTION.**
4. Replace fuel cap on tank. Make sure cap is tightened securely.
5. Replace seat bottom.

BATTERY

Read **DANGER** and **WARNING** on page 3.

The battery in the DS Gasoline vehicle is a 12-volt, low maintenance battery that requires infrequent watering (**Figure 19, Page 20**). **See following DANGER and WARNING.**

⚠ DANGER

- **BATTERY - EXPLOSIVE GASES! DO NOT SMOKE! KEEP SPARKS AND FLAMES AWAY FROM THE AREA OF THE VEHICLE.**
- **TOOLS, WIRES, AND METAL OBJECTS CAN CAUSE SPARKS WHEN SHORTED ACROSS A BATTERY.**
- **FOLLOW ALL INSTRUCTIONS CAREFULLY WHEN WORKING WITH BATTERIES.**
- **CHARGE BATTERY IN A WELL-VENTILATED AREA ONLY.**
- **POISON! CONTAINS ACID! CAUSES SEVERE BURNS - AVOID CONTACT WITH SKIN, EYES, OR CLOTHING. ANTIDOTES:**
 - **EXTERNAL: FLUSH WITH WATER FOR 15 MINUTES. CALL A PHYSICIAN IMMEDIATELY.**
 - **INTERNAL: DRINK LARGE QUANTITIES OF MILK OR WATER FOLLOWED WITH MILK OF MAGNESIA OR VEGETABLE OIL. CALL A PHYSICIAN IMMEDIATELY.**
 - **EYES: FLUSH WITH WATER FOR 15 MINUTES. CALL A PHYSICIAN IMMEDIATELY.**

⚠ WARNING

- **DO NOT JUMP START THE VEHICLE. TO CHARGE THE BATTERY, USE AN AUTOMOTIVE TYPE 12-VOLT CHARGER RATED AT 10 AMPS OR LESS.**

Any corrosion around the positive (+) or negative (-) terminals should be washed off with a solution of baking soda and water (1 cup per gallon of water). Rinse solution off the battery. Be sure terminals are tight. Let the terminals dry and then spray them with Club Car battery terminal spray (Club Car Part No.1014305). **See following CAUTION.**

⚠ CAUTION

- **IF BATTERY WIRE TERMINALS ARE DAMAGED OR CORRODED, THEY SHOULD BE REPLACED OR CLEANED AS NECESSARY. FAILURE TO DO SO MAY CAUSE THEM TO OVERHEAT DURING OPERATION.**

Be sure battery clamp is properly tightened. Tighten to 12 ft.lb (16.3 N-m). A loose battery clamp may allow the battery to become damaged from vibration or jarring.

If battery appears weak, have it charged by a trained technician. The battery should never be left discharged any longer than absolutely necessary (do not leave discharged overnight).

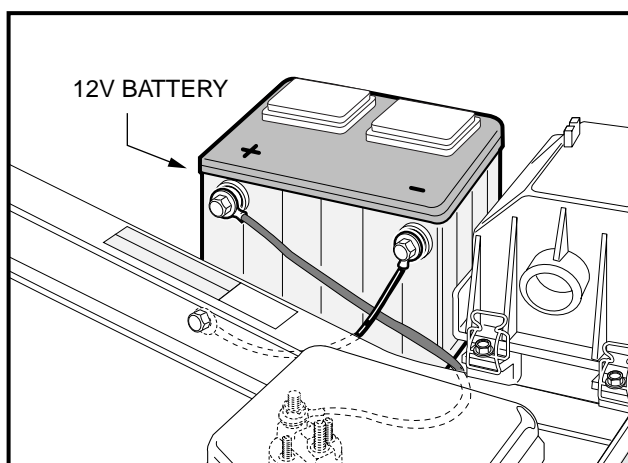

Figure 19 Battery

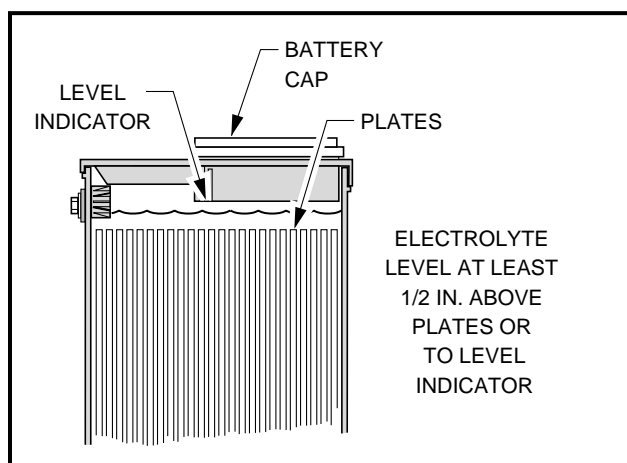

Figure 20 Electrolyte Level for Battery

CLEANING THE VEHICLE

Club Car vehicles are equipped with an Armorflex® front body and rear body. Use only commercially available automotive cleaners with a sponge or soft cloth for normal cleaning. A garden hose at normal operating residential water pressure is adequate.

Club Car does not recommend any type of pressure washing or steam cleaning. Such a process (especially if the vehicle has a soft rear body that is removed) will expose electrical components to moisture. Moisture entering electrical components can result in water damage and subsequent component failure.

Use non-abrasive wax products. Battery acid, fertilizers, tars, asphalt, creosote, paint or chewing gum should be removed immediately to prevent possible stains.

The seats of the vehicle will last longer with proper cleaning. Use a solution of 10% liquid dish soap and warm water applied with a soft cloth. For imbedded dirt, a soft bristle brush may be used. For heavy soiling, difficult stains or scratches, blemishes, or other body damage, see Section 4 of the DS Maintenance and Service Manual.

NOTE

- DISPOSE OF WASTE WATER PROPERLY.

ACCESSORIES

There is a complete line of accessory equipment available from Club Car and our dealers/distributors. Care should be taken that these accessories are properly installed by trained technicians, and that they are used in the manner for which they were designed. **See following WARNING.**

WARNING

- TINTED WINDSHIELDS AND WEATHER-PROOF ENCLOSURES WILL **NOT** PROTECT OCCUPANTS FROM FLYING OBJECTS (GOLF BALLS, ETC.).

ACCESSORY EQUIPMENT:

- | | | |
|-----------------------------|-----------------------------|------------------------------|
| • Accent Striping | • Rear View Mirror | • Differential Guard |
| • Custom Club Decals | • Glove Box | • Hour Meter |
| • Number Decals | • Performance Grade Tires | • Information Holder |
| • Canopy Top | • Standard Tread Tires | • Beverage Cooler |
| • Rear Rain Curtain | • Extra Traction Tires | • Extra Two-bag Attachment |
| • Weather-proof Enclosure | • Ashtray | • Sand Bunker Rake Kit |
| • Tinted Split Windshield | • Chrome Hub Wheel Covers | • Golf Club and Ball Cleaner |
| • Tinted Snap-on Windshield | • Chrome Sport Wheel Covers | • Fuel Gauge |
| • Club Protector | • Uncommon Key Switch | • Spark Arrestor Kit |

- Adjustable Seat Back
- Sand Bottle Divot Repair Kit
- Lighting Package (headlights, taillights, brake lights, and horn)
- Turn Signals (for vehicles with lights)
- Trailer Hitch
- Sand Basket and Divot Bucket Repair Kit
- Temporary Tow Bar for Single Vehicle Towing
- Permanent Tow Bar for Multiple Vehicle Towing (factory installed)
- Onboard Tow Bar
- Box Bed Kit
- Heavy Duty Front Bumper

SUBSEQUENT OWNER REGISTRATION

In the event a vehicle is bought as a used vehicle from another individual or from a distributor/dealer, we strongly urge the new owner to register the vehicle with Club Car. This will enable us to contact you if the need arises. Please send your name, address, and serial number(s) of the vehicle(s) to Club Car, Inc., P.O. Box 204658, Augusta, GA 30917-4658, ATTN: Vehicle Registration.

FAIRWAY VILLAGER

The Fairway Villager is designed to provide a smooth and comfortable ride for four passengers. An optional rack for two golf bags is also available. Contact your nearest Club Car distributor/dealer. This Owner's Manual should be read thoroughly prior to operating the vehicle.

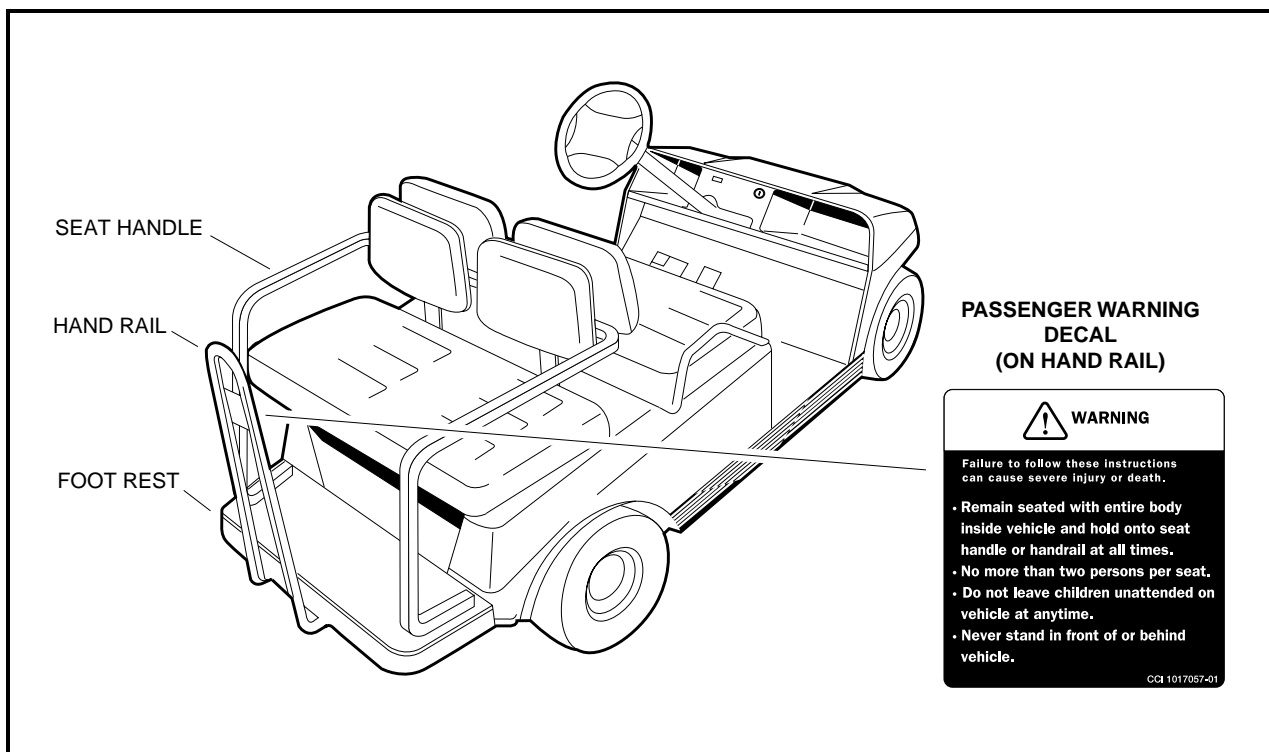

Figure 21 Fairway Villager

The Fairway Villager should be driven and maintained as stated in this Owner's Manual with the following additions:

⚠ WARNING

- VEHICLE SHOULD BE DRIVEN AT SLOWER SPEEDS WHEN FOUR PERSONS ARE IN THE VEHICLE.
- PASSENGERS SHOULD HOLD ON TO SEAT HANDLES OR HAND RAILS AT ALL TIMES (**SEE FIGURE 21, PAGE 22**). DRIVER SHOULD KEEP BOTH HANDS ON THE STEERING WHEEL WHILE VEHICLE IS MOVING.
- DO NOT LEAVE CHILDREN UNATTENDED ON THE REAR SEAT WHILE VEHICLE IS MOVING.
- NO MORE THAN FOUR PERSONS SHOULD BE ON THE VEHICLE AT ONE TIME.

MAINTENANCE

Refer to pages 16 through 17 for periodic service schedule and periodic lubrication schedule. **See following NOTE.**

NOTE

- IF THE VEHICLE IS CONSTANTLY HAULING HEAVY LOADS, THE PREVENTIVE MAINTENANCE PROCEDURES SHOULD BE PERFORMED MORE OFTEN THAN RECOMMENDED IN THE SERVICE AND LUBRICATION SCHEDULES.

DS GASOLINE VEHICLE SPECIFICATIONS

SPECIFICATIONS	DS
POWER SOURCE	
Engine: 4 cycle, OHV, 286 cc, 9.0 hp rated., single cylinder, air cooled, with pressure lubrication system.	•
Fuel System: Side draft carburetor with float bowl, fixed jets, fuel filter, and impulse fuel pump.	•
Governor: Automatic ground speed sensing, internally geared in unitized transaxle.	•
Ignition: Transistor electronic ignition with electronic RPM limiter.	•
Unitized Transaxle: Fully synchronized forward and reverse with neutral and reduced speed reverse (11.8:1 forward, 17.1:1 reverse).	•
Torque Converter: Automatic, variable speed, dry type.	•
Electrical System: 12 volt, 500 cca at 0°, 650 at 32°, 105 minute reserve capacity and 35 amp charging capacity.	•
STEERING/SUSPENSION/BRAKES	
Steering: Self-adjusting rack and pinion.	•
Suspension: Front and rear tapered mono-leaf springs with dual hydraulic shocks.	•
Brakes: Dual rear wheel self-adjusting brakes with cast iron drums and single brake pedal with automatic-release park brake.	•
BODY/CHASSIS	
Frame/Chassis: Twin I-Beam welded aluminum.	•
Front and Rear Body: Armorflex®	•
Body Finish: Matched paint finish over molded-in color.	•
Tires: 18.00 x 8.50 - 8.00 tubeless, 4 ply rated.	•
SEATING CAPACITY/FUEL CAPACITY	
Standard Seating Capacity: 2 persons	•
Fairway Villager Seating Capacity: 4 persons	•
Fuel Tank: 7 gallons (26.5 liters), unleaded gasoline only.	•

SPECIFICATIONS	DS
DIMENSIONS/WEIGHT	
Overall Length	91.5 in. (232 cm)
Overall Width	47.25 in. (120 cm)
Overall Height: At Steering Wheel.	48 in. (122 cm)
Wheelbase	65.5 in. (166 cm)
Ground Clearance	4.5 in. (11 cm)
Front Wheel Tread	34.5 in. (88 cm)
Rear Wheel Tread	38.5 in. (98 cm)
Weight: Standard gasoline powered vehicle (dry, without battery)	598 lb. (271 kg.)
Weight: Fairway Villager gasoline powered vehicle (dry)	638 lb. (289 kg.)
Forward Speed: At 2700 rpm	12-15 mph (19-24 kph)
Curb Clearance Circle (diameter)	17 ft. 6 in. (533 cm)
Braking Distance: At 12 mph (19 kph)	14 ft. (427 cm)

CLUB CAR LIMITED LIFETIME WARRANTY FOR 2000 FLEET GOLF CARS

1. WARRANTY:

CLUB CAR, INC., ("CLUB CAR") hereby warrants to the Original Retail Fleet Purchaser or Original Retail Fleet Lessee, as those terms are defined herein, and subject to the provisions, limitations and exclusions contained in this limited warranty, that its new 2000 Model DS golf car purchased from CLUB CAR or an authorized distributor or dealer for use in the United States or Canada shall be free from defects in materials and workmanship under normal use and service as a golf car for the periods stated below.

LIMITED LIFETIME WARRANTY:

The golf car frame (excluding the front and rear bumper mounts), the rack and pinion steering gearbox unit, and the suspension system (defined as the shock absorbers, shock mounts, A-plates, leaf springs, shackles and associated hardware) are warranted with respect to parts and labor against defects in materials and workmanship for the lifetime of the vehicle while owned by the Original Retail Fleet Purchaser or in the possession of the Original Retail Fleet Lessee.

LIMITED THREE YEAR WARRANTY:

The gasoline engine, transmission, torque converter (drive and driven), unitized transaxle, starter generator, transaxle (electric vehicle), and electric motor are warranted with respect to parts and labor against defects in materials and workmanship for a period of three years from the date of purchase while owned by the Original Retail Fleet Purchaser or in the possession of the Original Retail Fleet Lessee.

LIMITED TWO YEAR WARRANTY:

All remaining components of the golf car not specified otherwise, except options and accessories, are warranted with respect to parts and labor against defects in materials and workmanship for a period of two years from the date of purchase while owned by the Original Retail Fleet Purchaser or in the possession of the Original Retail Fleet Lessee.

LIMITED ONE YEAR WARRANTY:

All original equipment options and accessories supplied by Club Car are warranted with respect to parts and labor against defects in material and workmanship for a period of one year from the date of purchase.

This limited warranty covers materials, workmanship and repair labor cost as to those items specifically listed above for the periods specified. Such repair labor shall be performed only by CLUB CAR, its authorized distributors or dealers, or a service agency approved by CLUB CAR.

IF THE WARRANTY REGISTRATION FORM IS NOT COMPLETED AND RETURNED TO CLUB CAR AT THE TIME OF THE ORIGINAL RETAIL SALE, PURCHASER MUST PROVIDE PROOF OF DATE OF PURCHASE WITH ANY WARRANTY CLAIM.

2. EXCLUSIONS:

Excluded from any CLUB CAR warranty are all fuses, filters, decals (except safety decals), spark plugs, lubricants, and trim pieces, seats, routine wear items such as the charger plug and receptacle, brake shoes, belts, brushes, bushings, engine mounts, mats and pads, maintenance adjustments, cosmetic deterioration, and items which deteriorate or fail due to exposure or ordinary wear and tear. Batteries, the battery charger, onboard computer, and solid-state speed controller are covered under separate CLUB CAR warranties. Tires are warranted by their manufacturer. Also excluded from any CLUB CAR warranty is damage to a golf car or component resulting from a cause other than a defect including unreasonable or unintended strain or use, improper installation of accessories, installation of parts or accessories that are not original equipment, overloading, accident, alteration, abuse or neglect.

Transportation expenses for warranty service are also excluded from this warranty.

3. VOIDING OF WARRANTY:

THIS AND ANY OTHER WARRANTY SHALL BE VOID IF THE GOLF CAR IS ABUSED OR USED IN AN UNINTENDED MANNER OR SHOWS INDICATIONS THAT IT HAS BEEN ALTERED IN ANY WAY, INCLUDING, BUT NOT LIMITED TO, MODIFICATION OF THE SPEED GOVERNOR, BRAKING SYSTEM, STEERING, TRANSAXLE, OR OTHER OPERATING SYSTEMS OF THE CAR TO CAUSE IT TO PERFORM OUTSIDE CLUB CAR SPECIFICATIONS. THE WARRANTY IS LIKEWISE VOID IF THE CAR SHOWS INDICATIONS THAT REASONABLE OR NECESSARY MAINTENANCE AS OUTLINED IN THE OWNER'S MANUAL AND MAINTENANCE AND SERVICE MANUAL WAS NOT PERFORMED AT THE TIME AND IN THE MANNER SPECIFIED IN SUCH MANUALS.

4. SOLE REMEDY:

CLUB CAR's only liability under this limited warranty, or in any action whether based upon warranty, contract, negligence, strict product liability or otherwise, is limited to the repair or replacement, at CLUB CAR's option, of a golf car or component thereof that CLUB CAR deems to be defective. Replacement shall mean furnishing, during the applicable limited warranty period, a new golf car or factory reconditioned vehicle or component thereof which is identical or reasonably equivalent to the warranted product or component at no cost to the purchaser. Repair shall mean remedying a defect in the golf car or component thereof at no cost to the purchaser during the applicable limited warranty period. If CLUB CAR elects to repair the golf car, it may provide factory reconditioned parts or components. All parts and components replaced under warranty shall become the property of CLUB CAR.

5. HOW TO MAKE A WARRANTY CLAIM:

To make a warranty claim under this limited warranty, you must present the golf car or defective component to an authorized CLUB CAR distributor or dealer or send the defective component, freight prepaid, to WARRANTY ADMINISTRATION, CLUB CAR, INC., 4125 Washington Road, Augusta, Georgia 30809.

6. DEFINITIONS:

For the purpose of this warranty, an Original Retail Fleet Purchaser is the original purchaser of the golf car who is in the business of owning or operating golf courses and who purchases such golf car for the purpose of renting it to golf players for use on such courses. An Original Retail Fleet Lessee is the first end-user of the golf car who is in the business of owning and operating golf courses and who leases such golf car for the purpose of renting it to golf players for use on such golf courses. In the event the golf car is purchased or leased by any entity for the purpose of leasing it to an Original Retail Fleet Lessee, then this limited warranty shall extend only to the first Original Retail Fleet Lessee, and not to such entity or to any subsequent lessee of the golf car.

7. DISCLAIMER:

THIS LIMITED WARRANTY IS EXCLUSIVE. CLUB CAR MAKES NO OTHER WARRANTY OF ANY KIND, EXPRESS OR IMPLIED. ANY IMPLIED WARRANTIES OF MERCHANTABILITY OR FITNESS FOR A PARTICULAR PURPOSE WHICH EXCEED THE OBLIGATIONS OR TIME LIMITS STATED IN THIS WARRANTY ARE HEREBY DISCLAIMED BY CLUB CAR AND EXCLUDED FROM THIS WARRANTY. THE PURCHASER AND CLUB CAR EXPRESSLY AGREE THAT THE REMEDY OF REPAIR OR REPLACEMENT OF THE DEFECTIVE GOLF CAR OR COMPONENT THEREOF IS THE EXCLUSIVE AND SOLE REMEDY OF THE PURCHASER. CLUB CAR MAKES NO OTHER REPRESENTATION OR WARRANTY OF ANY KIND, AND NO REPRESENTATIVE, EMPLOYEE, DISTRIBUTOR, OR DEALER OF CLUB CAR HAS THE AUTHORITY TO MAKE OR IMPLY ANY REPRESENTATION, PROMISE, OR AGREEMENT WHICH IN ANY WAY VARIES THE TERMS OF THIS WARRANTY.

8. NO CONSEQUENTIAL DAMAGES:

IN NO EVENT SHALL CLUB CAR BE LIABLE FOR ANY INCIDENTAL OR CONSEQUENTIAL DAMAGES INCLUDING, BUT NOT LIMITED TO, LOSS RELATED TO PROPERTY OTHER THAN THE GOLF CAR, LOSS OF USE, LOSS OF TIME, INCONVENIENCE, OR ANY OTHER ECONOMIC LOSS.

Some states allow neither limitation on the duration of an implied warranty nor exclusions or limitation of incidental or consequential damages. Therefore, the above limitations or exclusions may not apply to you.

This warranty gives you specific legal rights, and you may also have other rights which vary from state to state.

9. INFORMATION:

For further information, contact WARRANTY ADMINISTRATION, CLUB CAR, INC., 4125 Washington Road, Augusta, Georgia 30809, U.S.A., 706-863-3000.

10. WARNING:

Any modification or alteration of any golf car beyond factory specifications, including those that affect the weight distribution, stability, or speed of the golf car, can cause serious personal injury or death.

Publication Part Number 102067301
Edition Code 0899B00000



Club Car, Inc.
P.O. Box 204658
Augusta, GA 30917-4658
USA

Web	www.clubcar.com
Phone	1.706.863.3000
	1.800.ClubCar
Int'l	+1 706.863.3000
Fax	1.706.863-5808