

INSTALLATION INSTRUCTION

Front Fender Installation (Ref Fig 1)

- 1- Install fender onto vehicle by placing the upper flange (with 4 holes) on the inside of the hood, and the vertical portion on top of the bracket with (3) mounting holes
- 2- Install (4) screws into the hood and through the fender flange
- 3- Install (4) nuts on the back side (inside of hood) to attach the upper fender
- 4- Install (3) screws through the fender and into the bracket with speed nuts attached
- 5- Tighten fasteners being careful not to overtighten and damage plastics
- 6- Repeat for opposite side

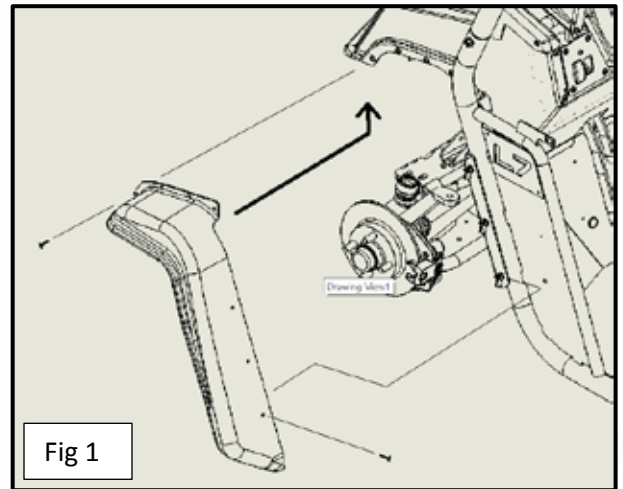

Rear Fender Installation (Ref Fig 2)

- 1- Install fender by slipping the slot over the steel bracket where (3) speed nuts are attached
- 2- Rotate the rear of the fender towards the vehicle and align holes on steel bracket
- 3- Install (4) screws into the steel bracket speed nuts using caution not to overtighten
- 4- Place top of fender over the flat plastic panel and install (2) top screws
- 5- Repeat for opposite side

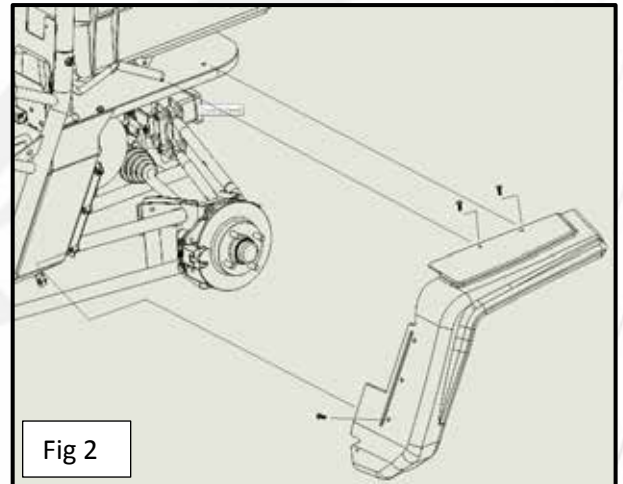

TOOLS REQUIRED

- 4mm Allen Wrench
- 10mm wrench

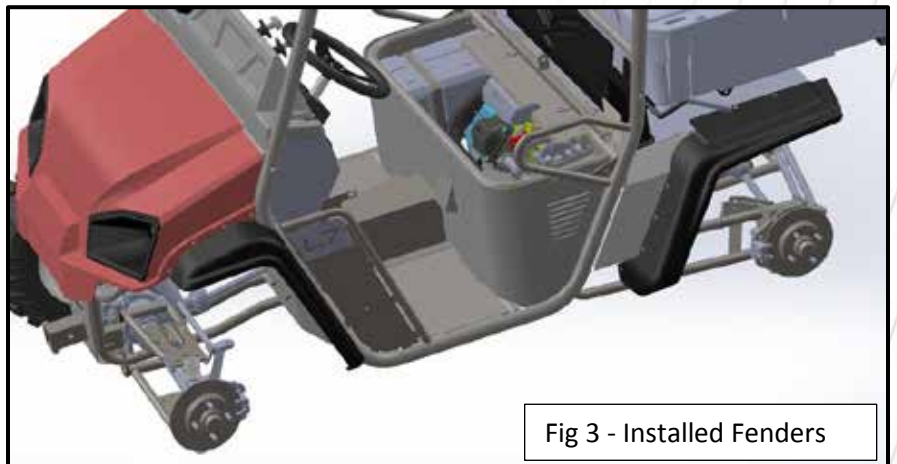

PN19193

REAR FENDERS

(top)

CORRECT



WRONG



Fender goes on top of plastic shield, not underneath.

CORRECT



(side)

WRONG



Slide fender slot over the silver steel bracket. Ensure holes are on top as shown in top picture.

FRONT FENDERS

CORRECT



WRONG



Upper flange of fender should be installed underneath hood, not on top.

CORRECT



WRONG



Vertical portion of fender gets mounted on top of metal plate. As shown on left.